



PIPE RACKING SYSTEM -JOINTS

ISO 9001/ ISO 14001 Certified

ADVANCED MECHATRONICS SOLUTIONS, INC www.ams-fa.com



METAL JOINT



Innovated Joints with Assembly Help Lines

S-Series Joint

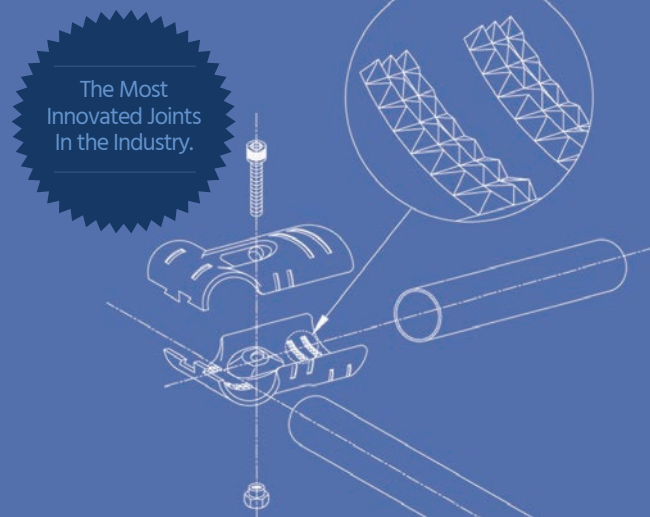

METAL JOINTS - SERIES FEATURES

Newly developed and patented design for Ø28 stainless steel pipes.
 Excellent grip characteristics achieved by introducing series of protruded pyramids in contact with stainless steel pipes.
 When used with coated pipes, grip is enhanced by 30%.

SURFACE TREATMENT & CODE NUMBER

Code	Surface Treatment	Remarks
●	Black Coating	Non Chrome
○	Zinc Plating (White)	Cro3
●	Nickel Plating	Non Chrome
●	Powder Coating (Ivory)	

FOR Ø28 (S-SERIES) METAL JOINTS

COLOR: ●BK ○WZ ●NI ●PI

Unit : mm

Model	Image	Dimensions (mm)	Weight (kg)	Q'ty/Box (pcs)
G-1S			0.068kg	240pcs
G-1BS			0.061kg	240pcs
G-2S			0.095kg	150pcs
G-3S			0.120kg	70pcs
G-4S			0.105kg	180pcs
G-6S			0.048kg	180pcs
G-6BS			0.042kg	240pcs
G-6B-33			0.046kg	180pcs
G-7AS			0.044kg	300pcs
G-7BS			0.052kg	300pcs

METAL JOINTS FOR Ø28 (S-SERIES)

COLOR: ● BK ○ WZ ● NI ● PI

Unit : mm

G-7CS

Utility Model Patent

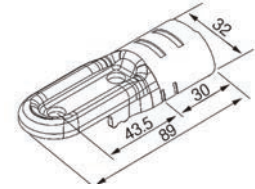

· Weight : 0.062kg
· Q'ty/Box : 210pcs

G-8S

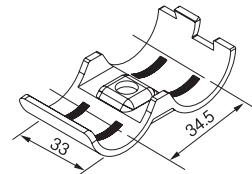

· Weight : 0.049kg
· Q'ty/Box : 300pcs

G-9S

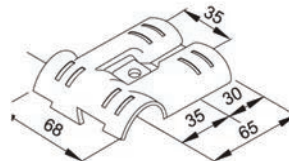

· Weight : 0.120kg
· Q'ty/Box : 100pcs

G-12S

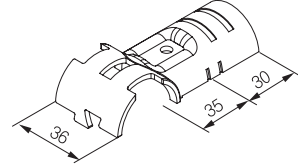

· Weight : 0.060kg
· Q'ty/Box : 210pcs

G-13AS

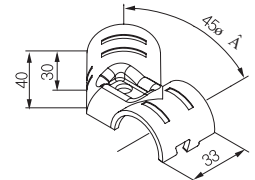

· Weight : 0.063kg
· Q'ty/Box : 160pcs

G-13BS

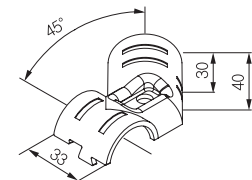

· Weight : 0.062kg
· Q'ty/Box : 160pcs

G-14S

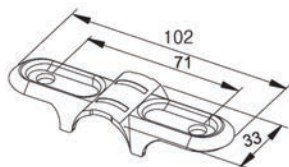

· Weight : 0.052kg
· Q'ty/Box : 270pcs

G-15AS

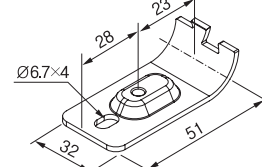

· Weight : 0.040kg
· Q'ty/Box : 480pcs

G-15BS

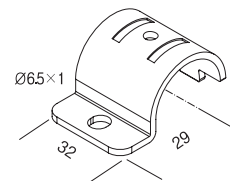

· Weight : 0.037kg
· Q'ty/Box : 480pcs

G-15AH

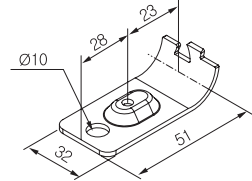

· Weight : 0.046kg
· Q'ty/Box : 300pcs

FOR Ø28 (S-SERIES) METAL JOINTS

COLOR: ● BK ○ WZ ● NI ● PI

Unit : mm

NEW G-15BL

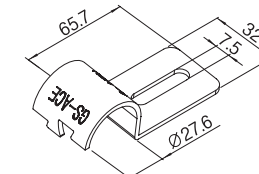

· Weight : 0.056kg
· Q'ty/Box : 240pcs

G-15D

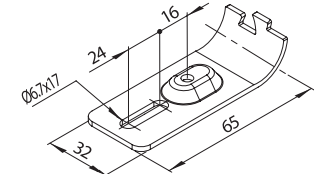

· Weight : 0.048kg
· Q'ty/Box : 300pcs

NEW G-15DL

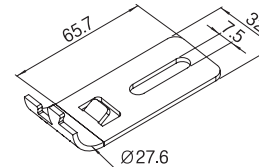

· Weight : 0.047kg
· Q'ty/Box : 300pcs

G-16S

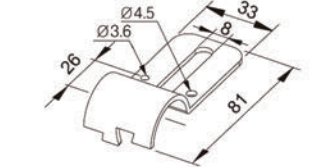

· Weight : 0.049kg
· Q'ty/Box : 300pcs

G-17S

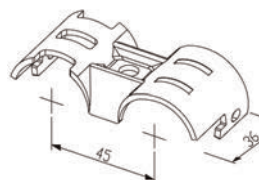

· Weight : 0.057kg
· Q'ty/Box : 200pcs

G-18S

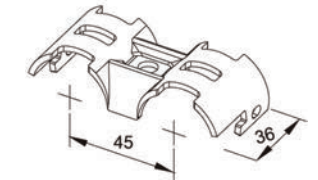

· Weight : 0.057kg
· Q'ty/Box : 180pcs

G-20S

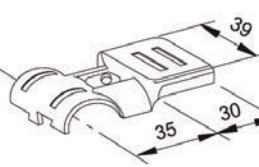

· Weight : 0.064kg
· Q'ty/Box : 200pcs

G-22S

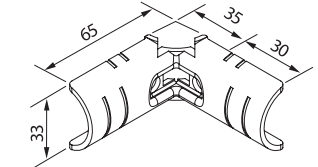

· Weight : 0.085kg
· Q'ty/Box : 150pcs

NEW G-23S

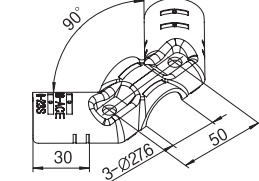

· Weight : 0.099kg
· Q'ty/Box : 130pcs

G-24S

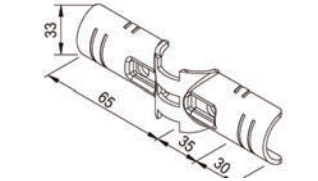

· Weight : 0.092kg
· Q'ty/Box : 150pcs

METAL JOINTS

METAL JOINTS

FOR Ø28 (S-SERIES)

ADVANCED MECHATRONICS SOLUTIONS, INC

METAL JOINTS FOR Ø28 (S-SERIES)

COLOR: ● BK ○ WZ ● NI ● PI

Unit : mm

G-25AS

- Weight : 0.050kg
- Q'ty/Box : 360pcs

G-25BS

- Weight : 0.043kg
- Q'ty/Box : 360pcs

G-25C

- Weight : 0.042kg
- Q'ty/Box : 300pcs

G-28

- Weight : 0.050kg
- Q'ty/Box : 240pcs

G-30S

- Weight : 0.060kg
- Q'ty/Box : 240pcs

G-34S

- Weight : 0.105kg
- Q'ty/Box : 180pcs

G-35AS

- Weight : 0.080kg
- Q'ty/Box : 240pcs

G-35BS

- Weight : 0.075kg
- Q'ty/Box : 240pcs

G-38S

- Weight : 0.057kg
- Q'ty/Box : 300pcs

G-44
Design Patent

- Weight : 0.070kg
- Q'ty/Box : 270pcs

FOR Ø28 (S-SERIES) METAL JOINTS

COLOR: ● BK ○ WZ ● NI ● PI

Unit : mm

G-45S

- Weight : 0.071kg
- Q'ty/Box : 200pcs

G-54S

- Weight : 0.099kg
- Q'ty/Box : 120pcs

G-60S

- Weight : 0.076kg
- Q'ty/Box : 200pcs

G-65S

- Weight : 0.038kg
- Q'ty/Box : 480pcs

G-65S-10 For Ø10

- Weight : 0.0380kg
- Q'ty/Box : 480pcs

G-66 Material : Aluminium

- Weight : 0.042kg
- Q'ty/Box : 120pcs

G-90S
Utility Model Patent

- Weight : 0.096kg
- Q'ty/Box : 100pcs

G-101

- Weight : 0.074kg
- Q'ty/Box : 180pcs

* For Ø28.6

G-102

- Weight : 0.074kg
- Q'ty/Box : 200pcs

* For Ø28.6

G-103

- Weight : 0.07kg
- Q'ty/Box : 240pcs

* For connection at the top of joint

COLOR: ● BK ○ WZ ● NI ● PI

Unit : mm

G-104

· Weight : 0.070kg
· Q'ty/Box : 240pcs

G-105

· Weight : 0.080kg
· Q'ty/Box : 200pcs

G-106

· Weight : 0.078kg
· Q'ty/Box : 200pcs

NEW G-301

· Weight : 0.077kg
· Q'ty/Box : 180pcs

G-110S

Design Patent

· Weight : 0.103kg
· Q'ty/Box : 100pcs

G-135S

· Weight : 0.102kg
· Q'ty/Box : 100pcs

G-160S

Design Patent

· Weight : 0.105kg
· Q'ty/Box : 100pcs

G-16WP

· Weight : 0.128kg
· Q'ty/Box : 50pcs

[Example for GA-15S]

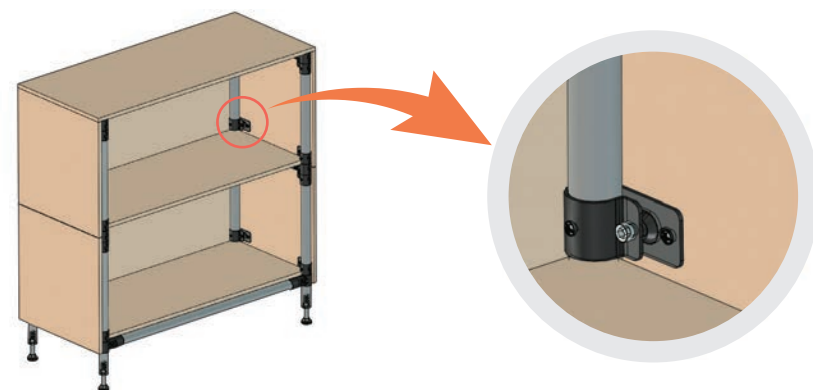

COLOR: ● BK ○ WZ ● NI ● PI

Unit : mm

GA-1S

Material	Metal
G-1S	2pcs
M0625/TN06	1set

GA-1BS

Material	Metal
G-1BS	2pcs
M0625/TN06	1set

GA-2S

Material	Metal
G-2S	1pcs
G-3S	1pcs
M0625/TN06	2set

GA-3S

Material	Metal
G-2S	2pcs
G-4S	1pcs
M0625/TN06	3set

GA-4S

Material	Metal
G-4S	2pcs
M0625/TN06	2set

COLOR: ● BK ○ WZ ● NI ● PI

Unit : mm

GA-5S



Material	Metal
G-2S	4pcs
M0625/TN06	4set

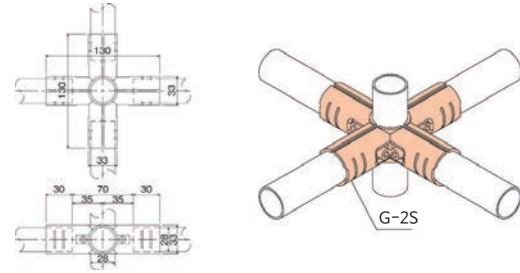

GA-6S



Material	Metal
G-6S	2pcs
M0625/TN06	1set

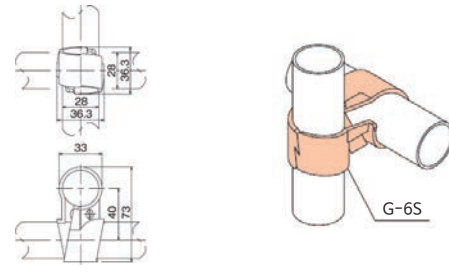

GA-6BS



Material	Metal
G-6BS	2pcs
M0625/TN06	1set

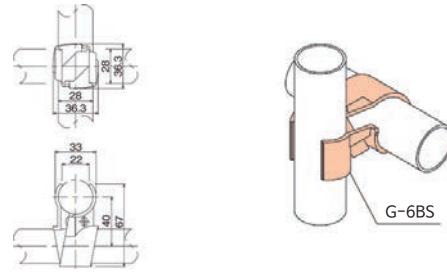

GA-6B-33



Material	Metal
G-6B-33	2pcs
M0625/TN06	1set

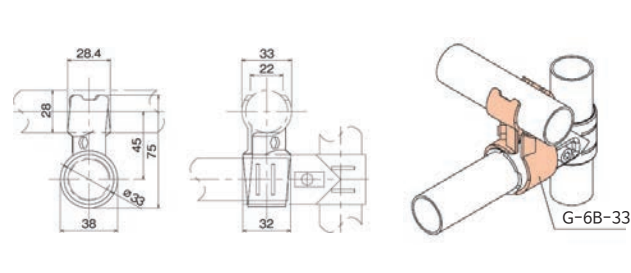

GA-7S



Material	Metal
G-7AS	2pcs
G-7BS	2pcs
M0625/TN06	2set

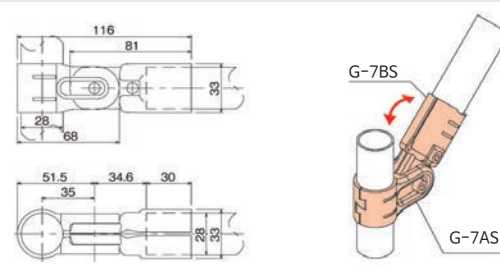

COLOR: ● BK ○ WZ ● NI ● PI

Unit : mm

GA-8S



Material	Metal
G-8S	2pcs
M0625/TN06	1set

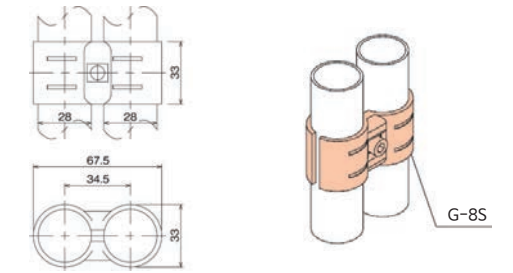

GA-9S



Material	Metal
G-9S	2pcs
M0625/TN06	1set

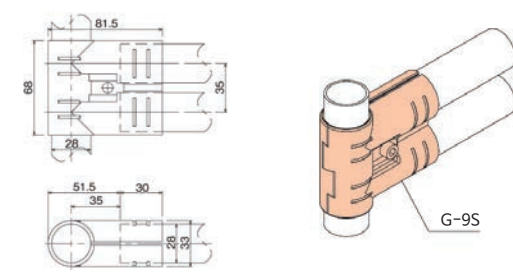

GA-12S

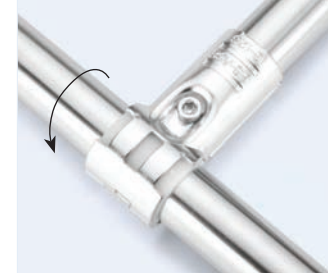

Material	Metal
G-12S	2pcs
GAP-12	1pcs
M0625/TN06	1set

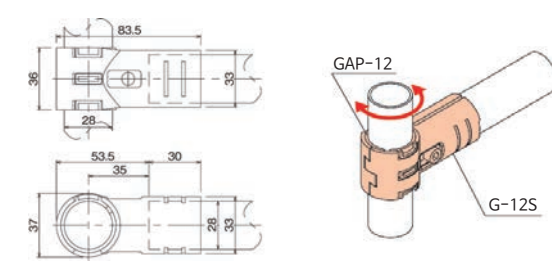

GA-13S



Material	Metal
G-13AS	1pcs
G-13BS	1pcs
M0625/TN06	1set

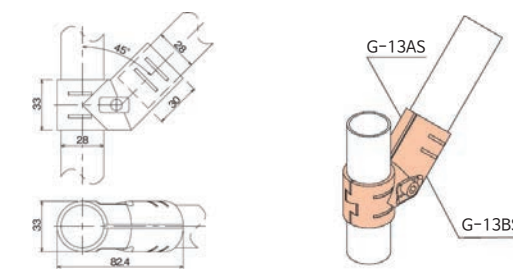

GA-14S



Material	Metal
G-14S	2pcs
G-7BS	4pcs
M0625/TN06	4set

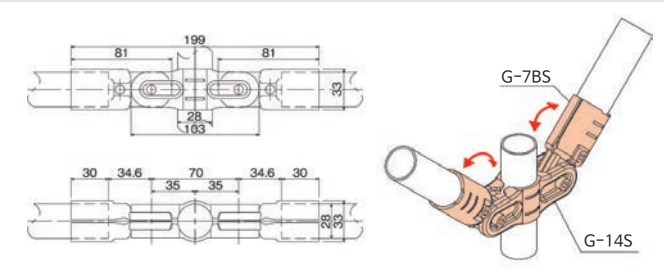

COLOR: ● BK ○ WZ ● NI ● PI

Unit : mm

GA-15S

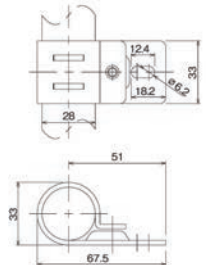
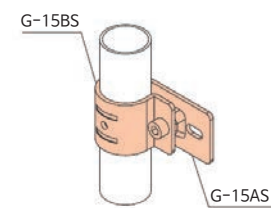

Material	Metal
G-15AS	1pcs
G-15BS	1pcs
M0610	1pcs

GA-15D



Material	Metal
G-15D	1pcs
G-15BS	1pcs
M0610	1pcs

GA-15H

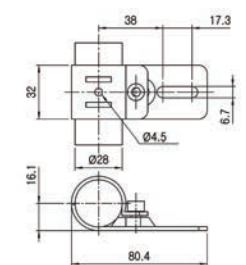
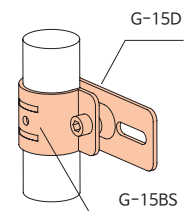

Material	Metal
G-15AH	1pcs
G-15BS	1pcs
M0610	1pcs

NEW GA-15L

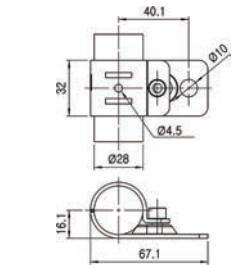
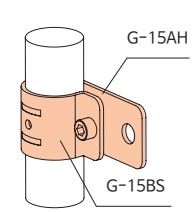

Material	Metal
G-15BL	1pcs
G-15DL	1pcs
M0615	1pcs
N06W-55	1pcs
PW06	1pcs

GA-16S

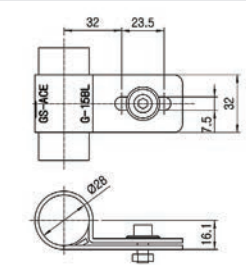
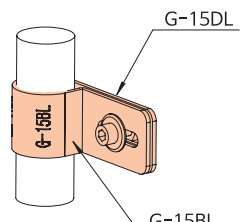

Material	Metal
G-16S	2pcs
PW8x25	2pcs

COLOR: ● BK ○ WZ ● NI ● PI

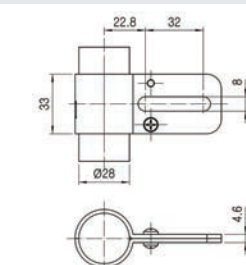
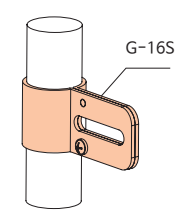
Unit : mm

GA-17S

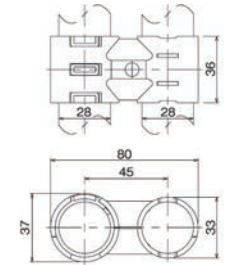
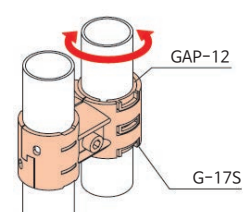

Material	Metal
G-17S	2pcs
GAP-12	1pcs
M0625/TN06	1set

GA-18S



Material	Metal
G-18S	2pcs
GAP-12	2pcs
M0625/TN06	1set

GA-20S

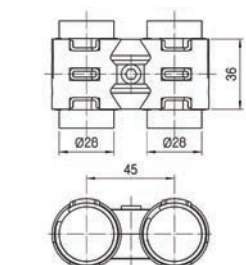
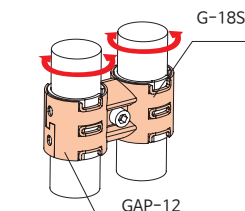

Material	Metal
G-20S	1pcs
G-1S	1pcs
M0625/TN06	1set

NEW GA-23S

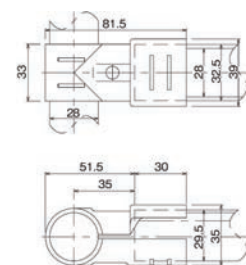
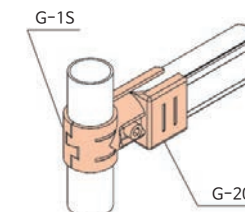

Material	Metal
G-23S	2pcs
M0625/TN06	2set

GA-24S

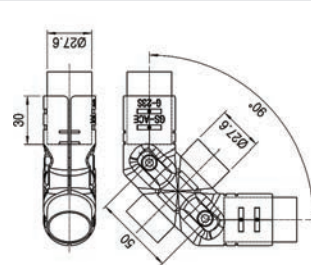
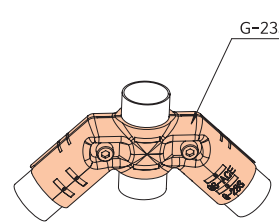

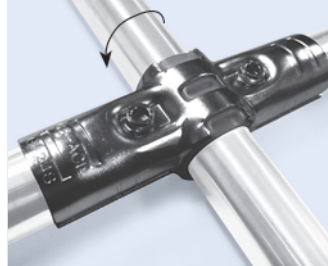
Material	Metal
G-24S	2pcs
GAP-12	1pcs
M0625/TN06	2 set

COLOR: ● BK ○ WZ ● NI ● PI

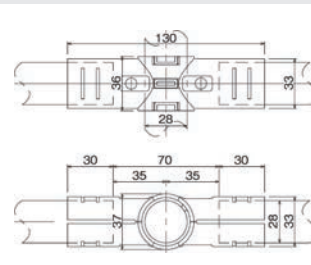
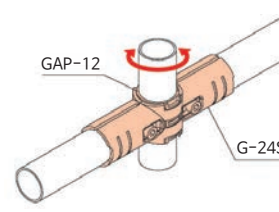
Unit : mm

GA-25S

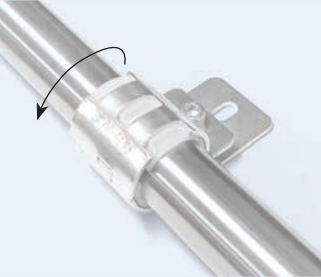

Material	Metal
G-25AS	1pcs
G-25BS	1pcs
GAP-12	1pcs
M0610	1pcs

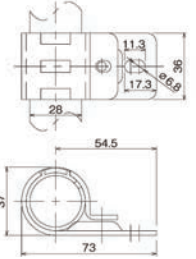
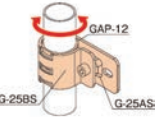
GA-25C



Material	Metal
G-25C	2pcs
GAP-12	1pcs
M0825/TN08	2set



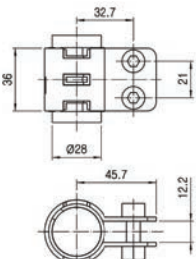
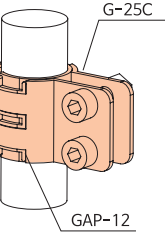

GA-27S

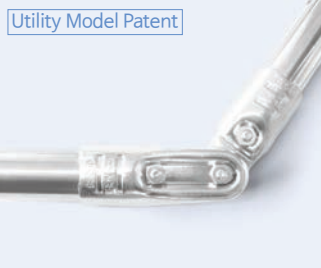
Utility Model Patent

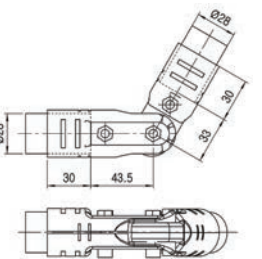
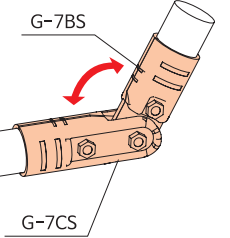

Material	Metal
G-7CS	2pcs
G-7BS	2pcs
M0625/TN06	3set

GA-28



Material	Metal
G-28	2pcs
M0625/TN06	1set

GA-30S

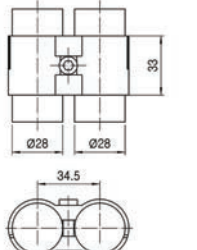
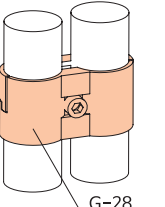

Material	Metal
G-30S	2pcs
M0625/TN06	1set

COLOR: ● BK ○ WZ ● NI ● PI

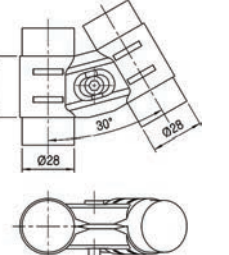
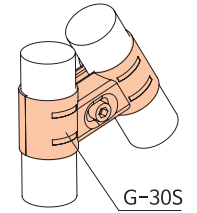
Unit : mm

GA-34S

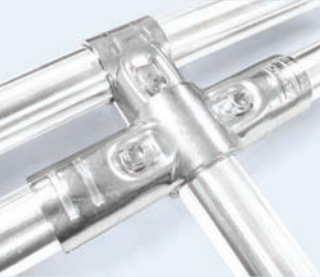

Material	Metal
G-34S	2pcs
M0625/TN06	2set

Joint for assembling with upper Joint

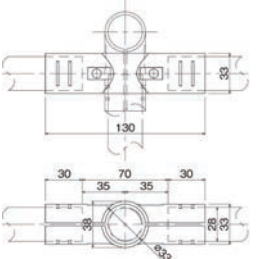
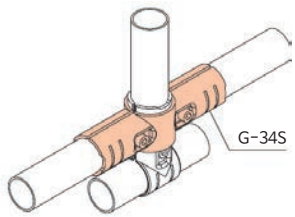
GA-35S

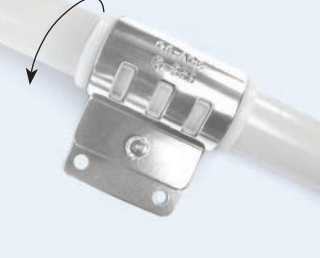

Material	Metal
G-35AS	1pcs
G-35BS	1pcs
GAP-56	1pcs
M0610	1pcs

GA-38S

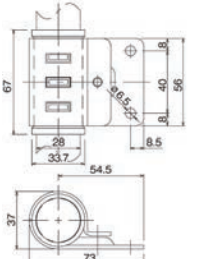
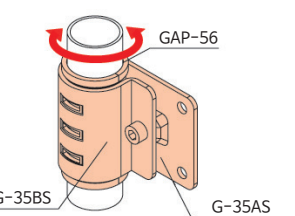

Material	Metal
G-38S	2pcs
M0625/TN06	1set



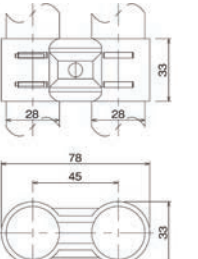
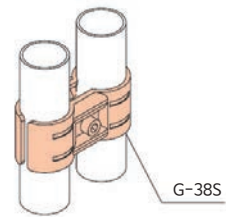

GA-44

Design Patent

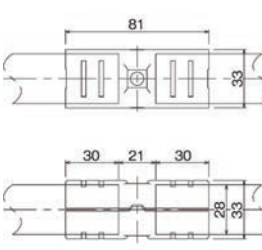
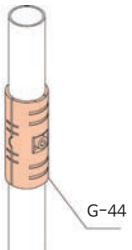

Material	Metal
G-44	2pcs
M0625/TN06	1set

GA-45S



Material	Metal
G-45S	2pcs
M0625/TN06	1set

COLOR : ● BK ○ WZ ● NI ○ PI

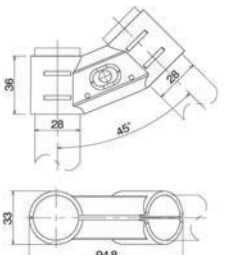
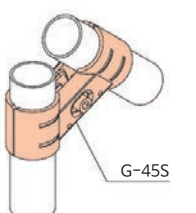
Unit : mm

GA-54S



Material	Metal
G-54S	1pcs
G-4S	1pcs
M0625/TN06	2set

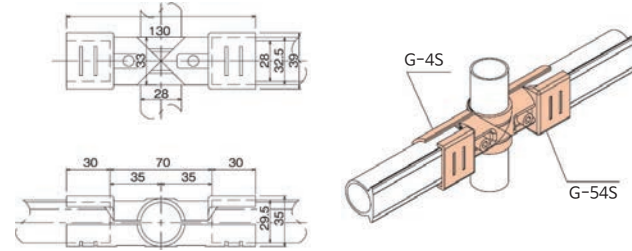

GA-55S



Material	Metal
G-22S	4pcs
GAP-12	1pcs
M0625/TN06	4set

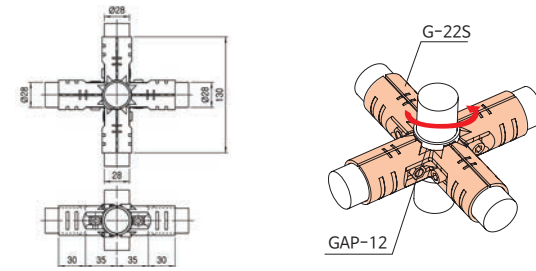

GA-60S



Material	Metal
G-60S	2pcs
M0625/TN06	1set

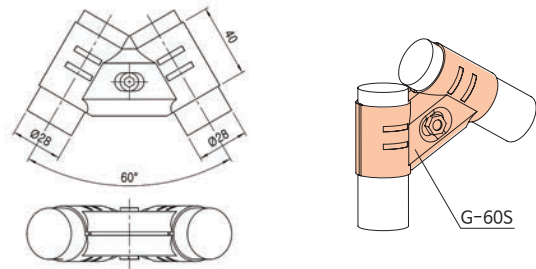

GA-65S

For Ø5



Material	Metal
G-65S	2pcs
M0610/TN06	1set

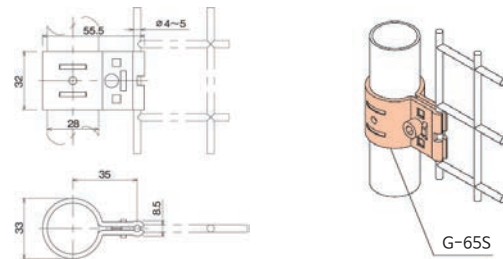

GA-65S-10

For Ø10



Material	Metal
G-65S-10	2pcs
M0615/TN06	1set

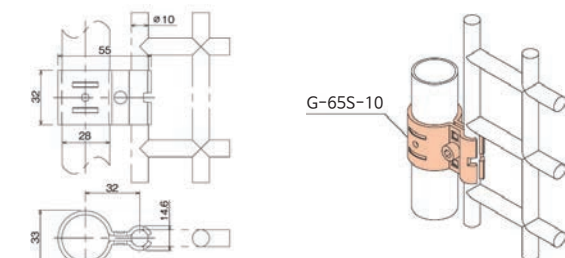

COLOR : ● BK ○ WZ ● NI ○ PI

Unit : mm

GA-66

Material : Aluminium



Material	Metal
G-66	2pcs
M0625/TN06	1set

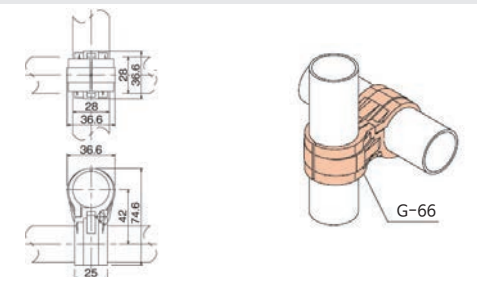

GA-90S

Utility Model Patent



Material	Metal
G-90S	2pcs
M0625/TN06	1set

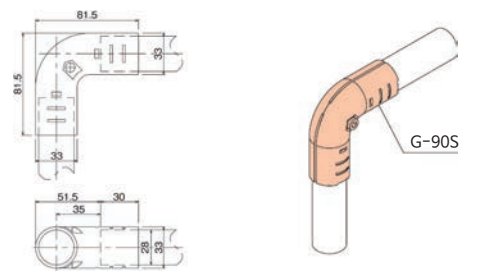

GA-101



Material	Metal
G-101	2pcs
M0625/TN06	1set

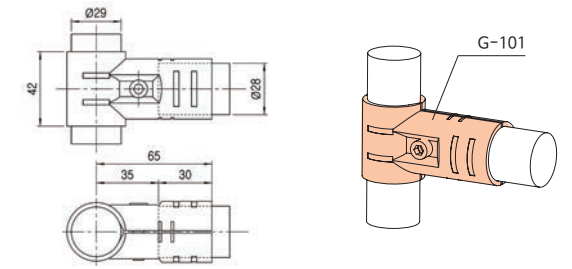

GA-102



Material	Metal
G-102	2pcs
M0625/TN06	1set

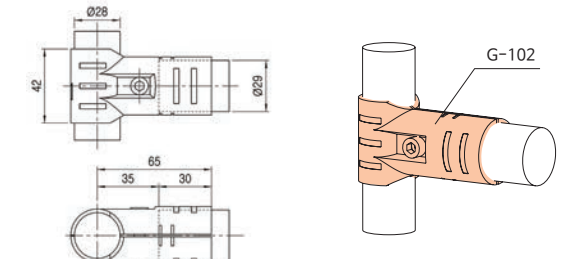

GA-103



Material	Metal
G-103	2pcs
M0625/TN06	1set

Joint for assembling with upper Joint

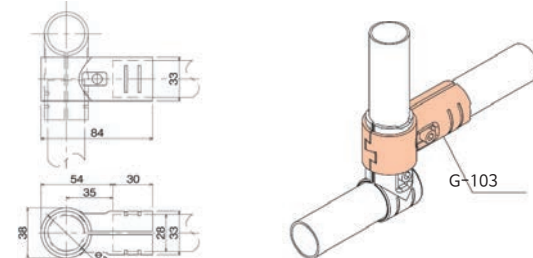

COLOR: ● BK ○ WZ ● NI ● PI

Unit : mm

GA-104

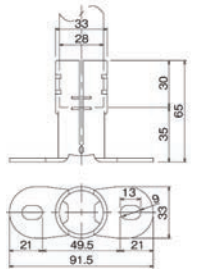
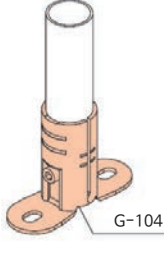

Material	Metal
G-104	2pcs
M0625/TN06	1set

GA-105



Material	Metal
G-105	2pcs
M0625/TN06	1set

GA-106

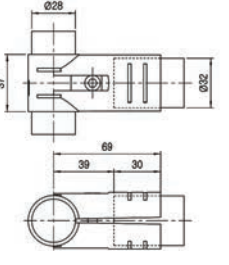
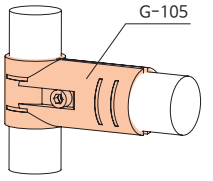

Material	Metal
G-106	2pcs
M0625/TN06	1set



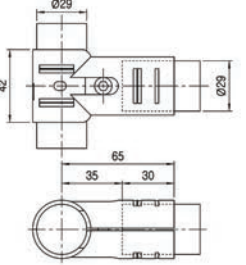
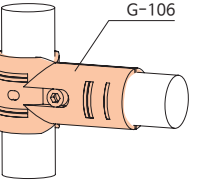

GA-110S

Design Patent

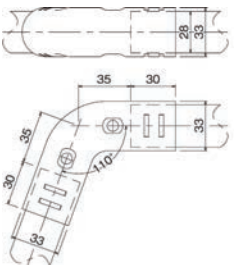
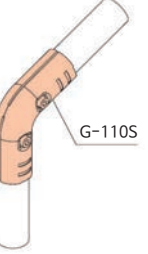

Material	Metal
G-110S	2pcs
M0625/TN06	2set

GA-135S



Material	Metal
G-135S	2pcs
M0625/TN06	2set



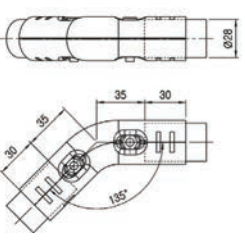
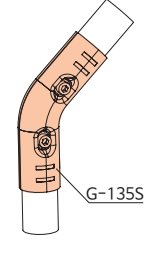

COLOR: ● BK ○ WZ ● NI ● PI

Unit : mm

GA-160S

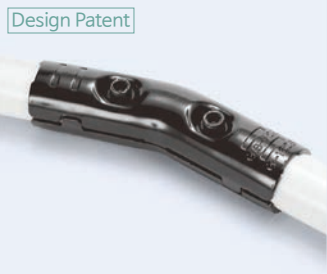
Design Patent

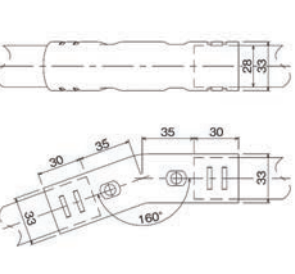
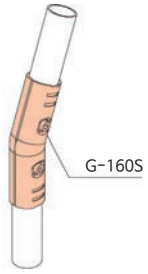

Material	Metal
G-160S	2pcs
M0625/TN06	2 set

NEW GA-301



Material	Metal
G-301	2pcs
M0625/TN06	1set

[Example for GA-301]

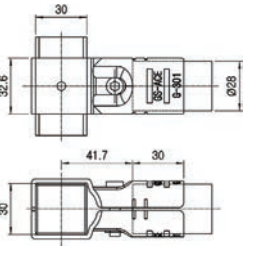
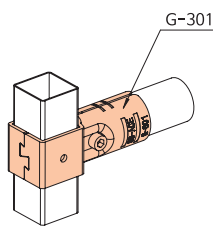

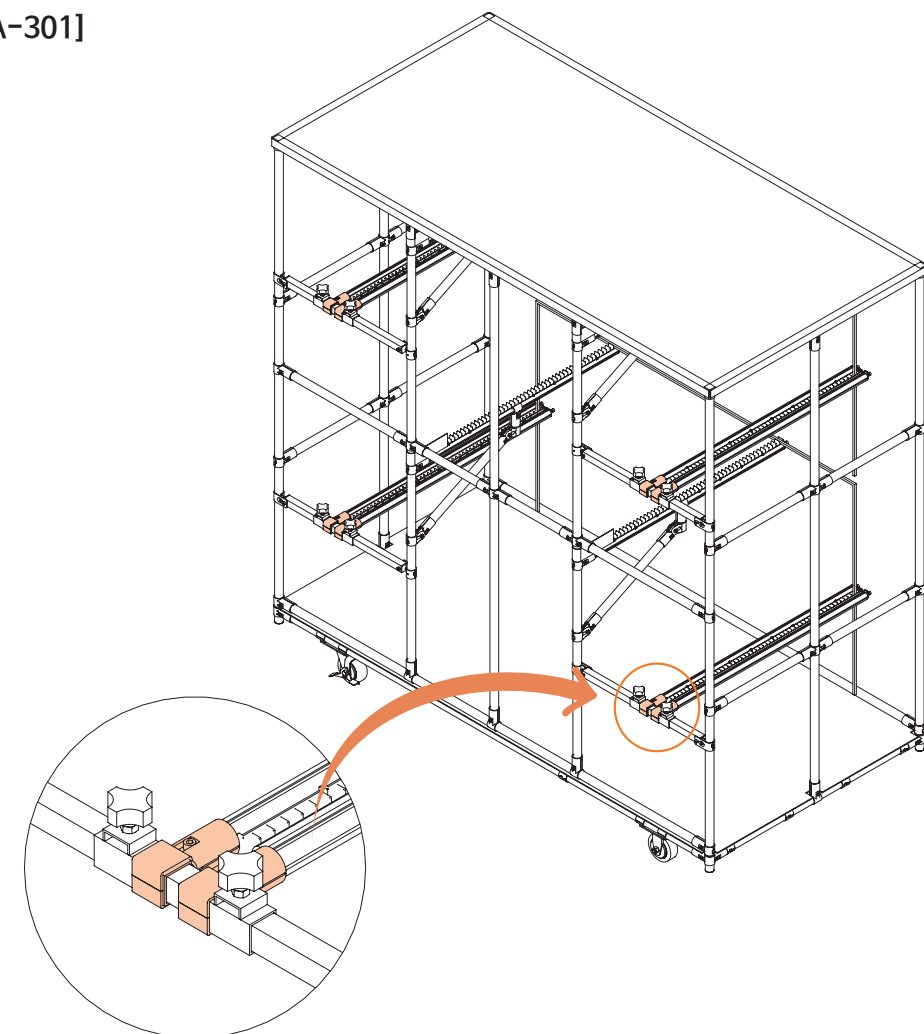

AMS, INC. Advanced Mechatronics Solutions, Inc.

10030 Via de la Amistad, San Diego, CA 92154 ☎ +1 (619) 661-5985 🖨 +1 (619) 661-5995 @ ams@ams-fa.com



AMS do BRASIL AMS Do Brasil Automacao Industrial LTDA de CV

Rua Laerte de Paiva, 344 Bairro Macuco Valinhos-SP-CEP 13279.451 ☎ +5 (19) 849-5555 @ quote@ams-fa.com



AMS de MEXICO AMS Factory Automation de Mexico SA de CV de CV

Polígono Buenavista -- Calle Cementera Lote 9, Mz 8 Ejido Buenavista - Querétaro, Qro. 76225

☎ +52 (442)312-0920 @ mexico@ams-fa.com