



SMT TOTAL SOLUTION

SMT NOZZLE & PARTS
CLEANING MACHINES



AMS ADVANCED
MECHATRONICS
SOLUTIONS, INC
AUTOMATION, SMT & LEAN MANUFACTURING

 **USA:** 10030 Via de la Amistad, San Diego, CA 92154
Call: (619) 661.5985 **Fax:** (619) 661.5995
Email: ams@ams-fa.com

 **BRAZIL:** Estrada Municipal Mario Covas. 641 Cond. Industrial
Portal Anhanguera Macuco-Valinhos, SP 13279-411
Call: +55 (19) 2511.4943 **Email:** quote@ams-fa.com

 **MEXICO:** Av. Hercules 301B-17, Poligono Empresarial Sta.
Rosa Jauregui, Queretaro, Qro, C.P. 76220
Call: +52 442.312.0920 **Email:** support@ams-fa.com



PANASONIC

AM100



PART No.	NAME	SPECIFICATION	MATERIAL	REMARK
	256M	0.39x0.3	CERAMIC	0402
	225M	0.6x0.35	CERAMIC	0603
	226M	0.6x0.5	CERAMIC	0603,1005
	230M	1.0x0.6	CERAMIC	1005,1608
	235M	1.6x0.8	CERAMIC	1608-3216
	387M	1.6x1.1	CERAMIC	3216,4532
	120MT	Φ1.3/Φ0.9	METAL	2012,3216
	240MT	Φ2.4/Φ1.8	METAL	3216,4532
	260M	Φ5.0/Φ3.0	METAL	TAN
	184MTR	Φ6.0/Φ4.0	METAL	SOP,QFP
	140M	Φ4.0	RUBBER	IC
	185M	Φ6.0	RUBBER	QFP,PLCC
	388M	Φ7.0	RUBBER	QFP,PLCC
	389M	Φ8.0	RUBBER	QFP,PLCC
	199MR	Φ10.0	RUBBER	Large Component

DT401, NPM-2/3HEAD

PART No.	NAME	SPECIFICATION	MATERIAL	REMARK
	1582N	0.65x0.35	CERAMIC	0603
N610098969AA	1001N	1.3x0.9	METAL/PLASTIC	1005
N610098969CA	1001CN	1.3x0.9	CERAMIC	1005
N610098970AA	1002N	3.0x2.2	METAL/PLASTIC	3216
N610098970CA	1002CN	3.0x2.2	CERAMIC	3216
N610098971AA	1003N	4.0x3.0	METAL	SOP,QFP
N610098972AA	1004N	Φ8.0	RUBBER	SOP,QFP
N610098973AA	1005N	Φ10.0	RUBBER	Large Component
N610114702AA	1006N	CALIBRATION		



CM602(12H), NPM-16HEAD

PART No.	NAME	SPECIFICATION	MATERIAL	REMARK
	204CSN	0.35x0.35	CERAMIC	
N610017370AC	205CS	0.65x0.35	CERAMIC	0603
N610030510AC	206CS	0.5x0.6	CERAMIC	0603-1005
N610038265AA	256CSN(203ZSN)	0.45x0.3	CERAMIC	0402
101YCO-K0210	210CS	1.1x0.6	CERAMIC	1005
	218CS(209CS)	0.6x0.5	CERAMIC	1005
N610040786AA	225CSN	0.6x0.35 (X)	CERAMIC	0603
N610119480AB	226CSN	0.5x0.6 (X)	CERAMIC	0603-1005
N610119484AB	230CSN	1.0x0.7 (X)	CERAMIC	1005-1608
N610119485AB	235CSN	1.6x0.8 (王)	CERAMIC	1608-3216
N610119486AB	240CSN	Φ2.4/Φ1.8	CERAMIC	3216-4512
N610119444CB	110CSN	Φ0.6/Φ0.4	CERAMIC	1005
N610119444AB	110SN	Φ0.6/Φ0.4	METAL	1005
N610119450CB	115CSN	Φ0.9/Φ0.65	CERAMIC	1608
N610119450AB	115SN	Φ0.9/Φ0.65	METAL	1608
N610119456CA	120CSN	Φ1.3/Φ0.9	CERAMIC	2125
N610119456AA	120SN	Φ1.3/Φ0.9	METAL	2125
N610119461AA	130SN	Φ2.4/Φ1.8	METAL	3216
N610119473AA	140SN	Φ4.0	RUBBER	IC
N610126849AA	161SN	Φ1.3/Φ0.9 MELF	METAL	
	162SN	Φ1.8/Φ1.2 MELF	METAL	





CM402(8H), NPM-8HEAD

PART No.	NAME	SPECIFICATION	MATERIAL	REMARK
	204CN	0.35x0.35	CERAMIC	
N61000995AA	205A	0.65x0.35	CERAMIC	0603
N610015533AA	206A	0.5x0.6	CERAMIC	0603-1005
N610029201AA	256CN(203ZN)	0.45x0.3	CERAMIC	0402
101YCO-K0210	210A	1.1x0.6	CERAMIC	1005
	218(209)	0.6x0.5	CERAMIC	1005
N610040782AA	225CN	0.6x0.35 (X)	CERAMIC	0603
N610119490AB	226CN	0.5x0.6 (X)	CERAMIC	0603-1005
N610119493AB	230CN	1.0x0.7 (X)	CERAMIC	1005-1608
N610119496AB	235CN	1.6x0.8 (王)	CERAMIC	1608-3216
N610119499AB	240CN	Φ2.4/Φ1.8	CERAMIC	3216-4512
N610099372CA	110CN	Φ0.6/Φ0.4	CERAMIC	1005
N610099372AA	110N	Φ0.6/Φ0.4	METAL	1005
N610099373CA	115CN	Φ0.9/Φ0.65	CERAMIC	1608
N610099373AA	115N	Φ0.9/Φ0.65	METAL	1608
N610099374CA	120CN	Φ1.3/Φ0.9	CERAMIC	2125
N610099374AA	120N	Φ1.3/Φ0.9	METAL	2125
N610099375AA	130N	Φ2.4/Φ1.8	METAL	3216
N610099376AA	140N	Φ4.0	RUBBER	IC
N610126847AA	161N	Φ1.3/Φ0.9 MELF	METAL	
	162N	Φ1.8/Φ1.2 MELF	METAL	
KXFX0387A00	450	Φ6.0	RUBBER	SOP,QFP
KXFX03NGA00	460	Φ10.0	RUBBER	Large Component



BM-series, MSF

PART No.	NAME	SPECIFICATION	MATERIAL	REMARK
10862GH810AA	SX	0.4x0.6	CERAMIC	0603
10807GH811AG	SA	0.8x1.0	CERAMIC	1005
10807GH812AG	S	1.2x1.8	CERAMIC	1608-2125
10807GH813AF	M	3.4x4.0/Φ2.5	METAL	IC
10807GH814AF	ML	Φ6.0	Rubber	SOP,QFP
10807GH815AF	LA	Φ10.0	Rubber	SOP,QFP
10807GH817AF	CN-S	1.5/7.0		CONNECTOR
10870GH818AF	CN-M	2.1/16.0		CONNECTOR
	CN-R1	5x12	METAL	
	CN-R2	1.8x20	METAL	
	CN-R3	4x25	METAL	
10807GH820AF	CN-R4	5x9.4	METAL	
10807GH821AF	CN-R5	0.8x9.6	METAL	
10807GH822AF	CN-R6	5x16	METAL	
	CN-R7	2.95x6.5	METAL	
10807GH823AF	CN-R8	1.2x2.8	METAL	
	CN-R10	2.4x13.4/2-HOLE	METAL	
10807GH824AF	CN-R11	2.1x14/SIDE-HOLE	METAL	
10807GHJ813AL	MELF	Φ1.3	METAL	MELF
10807GH825AF	CN-R12	5x15	METAL	



MSR, HT-series

PART No.	NAME	SPECIFICATION	MATERIAL	REMARK
10468S0002	VVS(NEW)	0.5x0.65	CERAMIC	OCTAGON
10468S0002	VVS(OLD)	0.5x0.6	CERAMIC	RECTANGLE
10468S0003	VS	0.6x1.0	CERAMIC	1005
10468S0004	S	1.0x1.6	CERAMIC	1608-2125
1046710134	M	Φ1.65/Φ1.2	CERAMIC	3216
10467S0001	L	Φ3.0/Φ2.5	METAL	4532,IC/M
10467S0002	LL	Φ5.5/Φ4.5	METAL	IC/M
10467S0003	LLL	Φ8.0	METAL	IC/L



PANASONIC

MV-series

PART No.	NAME	SPECIFICATION	MATERIAL	REMARK
1042 7732 71XX	SX	0.45x0.6	CERAMIC	
1042 8751 51XX	SA (X)	0.8x1.0	CERAMIC	
1020 1750 15XX	RSS (SS)	1.0x1.4	CERAMIC	
1022 4784 86XX	MA	1.2x1.8	METAL	
1020 1530 00XX	M	Φ1.2/Φ0.8	METAL	
1020 1795 61XX	M	Φ1.6/Φ1.2	METAL	
1020 1795 00XX	L	Φ3.0/Φ2.5	METAL	
1020 1750 11XX	LL	Φ5.5/Φ4.5	METAL	
1022 4790 22XX	LLL	Φ8.0	METAL	



HDP DISPENSER

PART No.	NAME	SPECIFICATION	MATERIAL	REMARK
1021570400	VS	1D/1S Φ0.7/Φ0.4	METAL	1608
1021570562	S	2D/1S Φ0.8/Φ0.5 P=1.2	METAL	2125
1021570542	L	2D/1S Φ1.0/Φ0.7 P=3.0	METAL	3216
1021570552	L	2D/1S Φ1.3/Φ1.0 P=3.0	METAL	3216
1021570432	S	2D/2S Φ0.7/Φ0.4 P=0.8	METAL	1608
1021570412	S	2D/2S Φ0.7/Φ0.4 P=1.0	METAL	2125
1021570572	S	2D/2S Φ0.8/Φ0.5 P=1.3	METAL	2125
	L	2D/2S Φ1.0/Φ0.7 P=1.2	METAL	3216
104305972101	L	2D/2S Φ1.1/Φ0.8 P=2.0	METAL	IC/S
1021570422	L	4D/1S Φ0.9/Φ0.6 P=3.0	METAL	IC/L
102157040101	NOZZLE HOUSING		METAL	



HDF DISPENSER

PART No.	NAME	SPECIFICATION	MATERIAL	REMARK
10430 59 700	VS	1D/1S Φ0.6/Φ0.3	METAL	1608
10483 70 240	VS	2D/2S Φ0.6/Φ0.3 P=0.7	METAL	1608
10430 59 710	S	2D/2S Φ0.7/Φ0.4 P=1.0	METAL	2125
10483 70 420	S	2D/2S Φ0.8/Φ0.5 P=1.0	METAL	2125
10483 70 220	VS	2D/2S Φ0.7/Φ0.4 P=0.8	METAL	1608
10430 59 721	L	2D/2S Φ1.1/Φ0.8 P=2.0	METAL	IC/S
10430 59 720	L	4D/1S Φ0.9/Φ0.6 P=3.0	METAL	IC/L



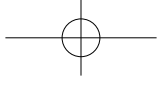

MPAG3, MPAV2B
MSH3
MSH2, MSH-G1
MMC-series
MCF-series



BD10S, BD12S-M DISPENSER

PART No.	NAME	SPECIFICATION	MATERIAL	REMARK
1020C0	S	2D/2S $\Phi 0.7/\Phi 0.4$ P=0.8	METAL	1608
1016C1	S	2D/2S $\Phi 0.8/\Phi 0.5$ P=0.9	METAL	2125
1017C1	M	2D/2S $\Phi 1.0/\Phi 0.7$ P=2.0	METAL	3216
	IC/S	2D/2S $\Phi 1.3/\Phi 1.0$ P=2.0	METAL	IC/S
1021C1	IC/L	4D/2S $\Phi 1.3/\Phi 1.0$ P=1.5	METAL	IC/L

BD20S, BD30S-M DISPENSER

PART NO.	NAME	SPECIFICATION	MATERIAL	REMARK
10HGCOM0000	10HGCO	1D/1S $\Phi 0.7/\Phi 0.4$	METAL	1608
10HJCOM0000	10HJCO	2D/2S $\Phi 0.7/\Phi 0.4$ P=0.8	METAL	1608
10HKCOM0000	10HKCO	2D/2S $\Phi 0.8/\Phi 0.5$ P=1.0	METAL	2125
10HLCOM0000	10HLCO	2D/2S $\Phi 1.0/\Phi 0.7$ P=1.2	METAL	3216
10HFCOM0000	10HFCO	2D/2S $\Phi 1.2/\Phi 0.9$ P=1.5	METAL	IC/S



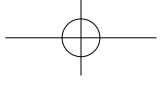

CM88

PART No.	NAME	SPECIFICATION	MATERIAL	REMARK
	0603	Φ0.65/Φ0.35	CERAMIC	0603
231C111116 (W13VA)	1005	Φ0.65/Φ0.45	METAL	1005
1231C111165 (W13YA)	1608	Φ0.9/Φ0.6	METAL	1608
1231C111125 (W13XA)	2125	Φ1.3/Φ0.9	METAL	2012-2125
	2125 MELF	Φ1.3/Φ0.9	METAL	
1231C111145 (W13WA)	3216	Φ1.8/Φ1.4	METAL	3216
	3216 MELF	Φ1.8/Φ1.4	METAL	
1231C111153 (W13ZA)	IC/S	Φ3.0/Φ2.2	METAL	IC/S
	IC/L	Φ4.0/Φ1.5	METAL	IC/L

CM82C-ME series
CM82C-MG series
CM85C-MGU series
CM86C-M2 series





YSM40

PART No.	NAME	SPECIFICATION	MATERIAL	REMARK
KLF-M87A0-A0	510A	0.25×0.35(○)	CERAMIC	0402
KLF-M8710-A0	511A	0.35×0.75(□)	CERAMIC	0603
KLF-M8720-A0	512A	1.2×0.45(□)	CERAMIC	1005
KLF-M8730-A1	513A	1.3×2.0(㉔)	CERAMIC	2012
KLF-M7710-A0	501A	0.8×0.7(X)	CERAMIC	1005
KLF-M7720-A0	502A	1.0×1.7(X)	CERAMIC	1608
KLF-M8740-A0	503A/514A	Φ4.0/3.0×2.0	METAL	
KLF-M8750-A0	504A/515A	Φ8.0	O-ring	



YS12, YS12F, YS12P, YS24, MG-3

PART No.	NAME	SPECIFICATION	MATERIAL	REMARK
KHY-M77A0-A0X	310A	0.25×0.35 (○)	CERAMIC	0402
KHY-M7710-A0X	311A	0.35×0.75 (□)	CERAMIC	0603
KHY-M7720-A0X	312A	1.2×0.45 (□)	CERAMIC	1005
KHY-M7730-A0X	313A	1.3×2.0 (㉔)	CERAMIC	2012
KHN-M7710-A1X	301A	0.8×0.7 (X)	CERAMIC	1005
KHN-M7720-A1X	302A	1.0×1.7 (X)	CERAMIC	1608
KHY-M7740-A0X	303A/314A	Φ4.0/3.0×2.0	METAL	IC
KHY-M7750-A0X	304A/315A	Φ8.0	O-ring	SOP,QFP
KHY-M7760-A0X	305A/316A	Φ15.0	O-ring	SOP,QFP
KHY-M7770-A0X	306A/317A	3.0×2.0	METAL	MELF
	309A	Φ1.2/Φ0.7	CERAMIC	1608



YV100X, YV100X-F

PART No.	NAME	SPECIFICATION	MATERIAL	REMARK
	0603	0.35×0.65	CERAMIC	0603
KV8-M7710-A0X	71A	0.7×0.8 (X)	CERAMIC	1005
KV8-M7720-A0X	72A	1.0×1.7 (X)	CERAMIC	1608
KV8-M7730-A1X	73A	Φ4.0/3.0×2.0	METAL	IC
KV8-M7740-A1X	74A	Φ8.0	O-ring	SOP, QFP
KV8-M7760-A1X	76A	3.0×2.0	METAL	MELF
KV8-M77WL-A00	79A	Φ1.2/Φ0.7	CERAMIC	1608
KV8-M71U1-002	71F	0.6×0.8 (X)	CERAMIC	1005
KV8-M71N2-A00	72F	1.0×1.7 (X)	CERAMIC	1608
KV8-M71N3-A00	73F	Φ4.0/3.0×2.0	METAL	IC
KV8-M7WL-A00	79F	Φ1.2/Φ0.7	CERAMIC	1608





YG100R, MG-1/8



PART No.	NAME	SPECIFICATION	MATERIAL	REMARK
	0603	0.35x0.65	CERAMIC	0603
KGS-M7710-A1X	211A	0.7x0.8 (X)	CERAMIC	1005
KGS-M7720-A1X	212A	1.0x1.7 (X)	CERAMIC	1608
KGS-M7730-01X	213A	Φ4.0/3.0x2.0	METAL	IC
KGS-M7740-A1X	214A	3.0x2.0	O-ring	IC
KGS-M7750-A1X	215A	Φ1.2/Φ0.7	O-ring	IC
KGS-M7760-01X	216A	0.7x0.8	METAL	MELF
KGS-M7790-A1X	219	1.0x1.7	CERAMIC	1608
	211F(71F)	0.7x0.8 (X)	CERAMIC	1005
	212F(72F)	1.0x1.7 (X)	CERAMIC	1608
	213F(73F)	Φ4.0/3.0x2.0	METAL	IC
	219F(79F)	Φ1.2/Φ0.7	CERAMIC	1608

YG200, YG300

PART No.	NAME	SPECIFICATION	MATERIAL	REMARK
	0603	0.35x0.65	CERAMIC	0603
KGT-M7710-A0	201	0.7x0.8 (X)	CERAMIC	1005
KGT-M7720-A0	202	1.0x1.7 (X)	CERAMIC	1608
KGT-M7730-A0	203	Φ4.0/3.0x2.0	METAL	IC
KGT-M7760-A0	206	3.0x2.0	CERAMIC	MELF
KGT-M7790-A0	209	Φ1.2/Φ0.7	CERAMIC	1608
KV8-M71N1-A0	201F(71F)	0.7x0.8 (X)	CERAMIC	1005
KV8-M71N2-A0	202F(72F)	1.0x1.7 (X)	CERAMIC	1608
KV8-M71N2-A0	203F(73F)	Φ4.0/3.0x2.0	METAL	IC
KV8-M71N9-A0	209F(79F)	Φ1.2/Φ0.7	CERAMIC	1608



YV88XG, YV88XG-F(EMERALD-XII)



PART No.	NAME	SPECIFICATION	MATERIAL	REMARK
KV7-M7710-A1X	61A	0.7x0.8 (X)	CERAMIC	1005
KV7-M7720-A1X	62A	1.0x1.7 (X)	CERAMIC	1608
KV7-M7730-00X	63A	Φ4.0/3.0x2.0	METAL	IC/S
KV7-M7740-A0X	64A	Φ10.0	O-ring	IC
KV7-M7750-A0X	65A	Φ15.0	O-ring	IC
KV7-M7760-00X	66A	3.0x2.0	O-ring	MELF
KV7-M71N1-A0X	61F	0.7x0.8 (X)	CERAMIC	1005
KV7-M71N2-A0X	62F	1.0x1.7 (X)	CERAMIC	1608
KV7-M71N3-A1X	63F	Φ4.0/3.0x2.0		IC
KV7-M71N4-A0X	69F	Φ1.2xΦ0.7	CERAMIC	1608



YVL88, YV100II(TOPAZ, EMERALD)

PART No.	NAME	SPECIFICATION	MATERIAL	REMARK
KM0-M711A-31X	31A	1.0x1.2 (X)	CERAMIC	1005
KM0-M711C-02X	32A	1.0x1.7 (X)	CERAMIC	1608-2012
KM0-M711B-00X	32-1	Φ4.0/3.0	REFLECTOR	IC
KM0-M711C-02X	32-2	Φ4.0/3.0	METAL	IC
KM0-M711D-00X	33	Φ10.0	O-ring	SOP, QFP
KM0-M711E-00X	34	Φ15.0	O-ring	SOP, QFP
KG7-M71AB-A0X	35	3.0x2.0	METAL	MELF
KM0-M711J-A0X	39	Φ1.2/Φ0.7	CERAMIC	1608



YM12D, YV64D, YV86D, YV100D

PART No.	NAME	SPECIFICATION	MATERIAL	REMARK
KG3-M7113-40X	1608	2D/2S Φ0.7/Φ0.4 P=0.8	METAL	1608
KM4-M7113-10X	2125	2D/2S Φ0.8/Φ0.5 P=1.0	METAL	2125
K37-M7113-40X	3216	2D/2S Φ0.9/Φ0.6 P=1.0	METAL	3216
K37-M7113-00X	IC	2D/2S Φ1.3/Φ1.0 P=2.0	METAL	IC



HSD DISPENSER

PART No.	NAME	SPECIFICATION	MATERIAL	REMARK
KV6-M7113-12X	111	2D/2S Φ0.7/Φ0.4 P=0.8	METAL	1608
KV6-M7113-23X	112	2D/2S Φ0.8/Φ0.5 P=1.3	METAL	2125
KV6-M7113-32X	113	2D/2S Φ1.2/Φ0.9 P=1.7	METAL	L
KV6-M7113-42X	114	1D/1S Φ0.7/Φ0.4	METAL	
KV6-M7113-52X	115	1D/1S Φ1.1/Φ0.8	METAL	
KV6-M7113-62X	116	1D/1S Φ1.8/Φ1.5	METAL	
KV6-M711A-00X	11A	2D/2S Φ0.7/Φ0.4 P=0.8	METAL	1608
KV6-M711B-00X	11B	1D/1S Φ1.3/Φ1.0	METAL	
KV6-M711C-00X	11C	1D/1S Φ1.6/Φ1.3	METAL	
KV6-M71LB-A0X	LBA	2D/1S 2-Φ0.4 P=0.9	METAL	1608 A.P
KV6-M71LC-A0X	LCA	2D/1S 2-Φ0.4 P=1.2	METAL	2012 A.P

**YAMAHA
I-PULSE**

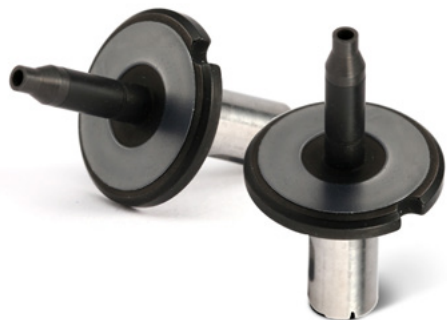

M1, M4

PART No.	NAME	SPECIFICATION	MATERIAL	REMARK
LG0-M771G-00	M031	0.46x0.4	CERAMIC	0603
LG0-M77KG-00	M032	0.9x0.6	CERAMIC	1005
	M033	0.9x0.7	CERAMIC	
LG0-M7701-000	M001	0.46x0.4	CERAMIC	0603
LG0-M7703-000	M002	0.9x0.6	CERAMIC	1005
LG0-M7705-000	M003	Φ1.3/Φ0.7	CERAMIC	1608-2012
LG0-M7707-000	M004	Φ1.8/Φ1.2	CERAMIC	2012-3216
LG0-M7709-000	M005	Φ3.0/Φ2.0	METAL	IC
LG0-M770B-000	M006	Φ4.5/Φ3.5	METAL	IC
LG0-M770D-000	M012	Φ2.0/Φ1.0	METAL	MELF
LG0-M770F-000	M013	Φ2.5/Φ1.2	METAL	MELF
LG0-M770H-000	M017	Φ4.0	RUBBER	IC
LG0-M770K-000	M018	Φ6.0	RUBBER	SOP,QFP
LG0-M770M-000	M019	Φ8.0	RUBBER	SOP,QFP
LG0-M770S-000	M020	Φ10.0	RUBBER	SOP,QFP
	M021	0.9x0.7	CERAMIC	1005
	M022	0.9x1.0	CERAMIC	

M2

PART No.	NAME	SPECIFICATION	MATERIAL	REMARK
LC1-M7712-00	N031	0.46x0.4	CERAMIC	0603
LC1-M7714-00	N032	0.9x0.6	CERAMIC	1005
LC6-M7716-00	N033	0.9x0.7	CERAMIC	
LC1-M7701-00	N001	0.46x0.4	CERAMIC	0603
LC1-M7703-00	N002	0.9x0.6	CERAMIC	1005
LC1-M7705-00	N003	Φ1.3/Φ0.7	CERAMIC	1608-2012
LC1-M7707-00	N004	Φ1.8/Φ1.2	CERAMIC	2012-3216
LC1-M7709-00	N005	Φ3.0/Φ2.0	METAL	IC
LC1-M770B-00	N006	Φ4.5/Φ3.5	METAL	IC
LC1-M770D-00	N012	Φ2.0/Φ1.0	METAL	MELF
LC1-M770F-00	N013	Φ2.5/Φ1.2	METAL	MELF
LC1-M770H-00	N017	Φ4.0	RUBBER	IC
LC1-M770K-00	N018	Φ6.0	RUBBER	SOP, QFP
LC1-M770M-00	N019	Φ8.0	RUBBER	SOP, QFP
LC1-M770P-00	N020	Φ10.0	RUBBER	SOP, QFP
LC1-M770S-00	N021	0.9x0.7	CERAMIC	1005
LC1-M770U-00	N022	0.9x1.0	CERAMIC	



M6, M7, M10, M20

PART No.	NAME	SPECIFICATION	MATERIAL	REMARK
LC6-M7712-10	P031	0.46x0.4	CERAMIC	0603
LC6-M7714-00	P032	0.9x0.6	CERAMIC	1005
LC7-M7716-01	P033	Φ1.3/Φ0.7	CERAMIC	1608
LC6-M7718-00	P034	Φ1.8/Φ1.2	CERAMIC	2012-3216
LC6-M7724-00	P042	0.9x0.7	CERAMIC	1005
LC6-M7709-001	P005	Φ3.0/Φ2.0	METAL	IC
LC6-M770B-001	P006	Φ4.5/Φ3.5	METAL	IC
LC6-M770D-001	P012	Φ2.0/Φ1.0	METAL	MELF
LC6-M770F-001	P013	Φ2.5/Φ1.2	METAL	MELF
LC6-M770H-003	P017	Φ4.0	RUBBER	IC
LC6-M770K-002	P018	Φ6.0	RUBBER	SOP, QFP
LC6-M770M-002	P019	Φ8.0	RUBBER	SOP, QFP
LC6-M770P-002	P020	Φ10.0	RUBBER	SOP, QFP
LC6-M7727-000	P050	Φ4.0	RUBBER	SOP, QFP
LC6-M7729-000	P051	Φ6.0	RUBBER	SOP, QFP
LC6-M7728-000	P052	Φ8.0	RUBBER	SOP, QFP
LC6-M772D-000	P053	Φ10.0	RUBBER	
LC6-M7735-000	P054	Φ1.8/Φ1.2	PAD	
LC6-M772K-000	P055	Φ3.0/Φ2.0	PAD	
LC6-M772V-000	P056	Φ4.5/Φ3.5	PAD	
LC6-M7731-000	P057	Φ6.0/Φ5.0	PAD	
LC6-M772F-000	P061	0.7x0.7	CERAMIC	
LC6-M772H-000	P062	1.7x0.9	CERAMIC	
LC6-M773B-001	P072	Φ2.0/Φ1.0	METAL	MELF
LC6-M773E-001	P073	Φ2.5/Φ1.2	METAL	MELF





Σ-G4, Σ-G5 (High speed)

PART No.	NAME	SPECIFICATION	MATERIAL	REMARK
HG21C---	HG21C/HG22C	0.5x0.3	CERAMIC	0402
HG32C---	HG31C/HG32C/HG33C	0.7x0.4	CERAMIC	0603
HV32C---	HV31C/HV32C	0.7x0.4	CERAMIC	0603
HG52C---	HG51C/HG52C/HG53C	1.1x0.6	CERAMIC	1005
HV51C---	HV51C/HV52C	1.1x0.6	CERAMIC	1005
HG82C---	HG81C/HG82C/HG83C	1.7x0.9	CERAMIC	1608
HV82C---	HV81C/HV82C	1.7x0.9	CERAMIC	1608
HV13C---	HV13C/HV03C	Φ1.3/Φ0.9	CERAMIC	2012
HV14C---	HV14C/HA04C	Φ1.8/Φ1.1	CERAMIC	3216
HV15C---	HV15C/HA05C	Φ3.0/Φ2.0	METAL	4523
HV19C---	HV19C/HA09C	Φ6.0/Φ4.5	METAL	SOP
HB03C---	HB03C	Φ1.3/Φ0.9	METAL	2012-3216 MELF
HB04C---	HB04C	Φ1.8/Φ1.1	METAL	3216-5922 MELF



GXH-1, GXH-3 (High speed)

PART No.	NAME	SPECIFICATION	MATERIAL	REMARK
630 137 5472	HA11	0.5x0.3	CERAMIC	0402
630 152 8267	HV31/HV32	0.7x0.4	CERAMIC	0603
630 158 6571	HG31/HG32	0.7x0.4	CERAMIC	0603
630 128 4842	HA10	0.7x0.4	CERAMIC	0603
630 152 8472	HV51/HV52	1.1x0.6	CERAMIC	1005
630 159 9632	HG51/HG52	1.1x0.6	CERAMIC	1005
630 129 2878	HV01	Φ0.6/Φ0.4	CERAMIC	1005
630 132 2322	PV01	1.1x0.6	CERAMIC	1005
630 158 9084	HV81/HV82	1.7x0.9	CERAMIC	1608
630 161 3501	HG81/HG82	1.7x0.9	CERAMIC	1608
630 129 2885	HV02	Φ0.9/Φ0.7	CERAMIC	1608
630 132 9857	PV02	1.7x0.9	CERAMIC	1608
630 129 2892	HV03	Φ1.3/Φ0.9	CERAMIC	2012-2125
630 129 2922	HV04	Φ1.8/Φ1.1	CERAMIC	3216
	HV05	Φ3.0/Φ2.0	METAL	4523
	HV09	Φ6.0/Φ4.5	METAL	SOP
630 129 2908	HB03	Φ1.3/Φ0.9	METAL	2012 MELF
630 129 2922	HA04	Φ1.8/Φ1.1	METAL	3216
630 129 2915	HB04	Φ1.8/Φ1.1	METAL	3216 MELF



MULTI SPEED

NAME				
RA04	VC29	VF02	VG46	VG93
RA05	VC31	VF05	VG51	VG99
RA06	VE01	VF06	VG52	VS03
RV01	VE03	VF07	VC75	VS04
VA06	VE05	VG02	VG60	VS05
VA07	VE07	VG03	VG64	VS08
VC02	VE11	VG04	VG65	VS09
VC04	VE18	VG25	VG67	VT11
VC05	VE23	VG29	VG69	VT14
VC07	VE35	VG33	VG70	VT16
VC12	VE41	VG34	VG71	FA04
VC13	VE45	VG35	VG76	FA05
VC14	VE52	VC74	VC76	FA06
VC15	VE82	VG42	VG91	FF01
VC16	VF01	VG45	VG92	FF02



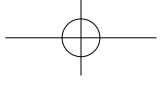

EXCEN

PART No.	NAME	SPECIFICATION	MATERIAL	REMARK
	VN030	0.5x0.3	CERAMIC	0603
	VN040	1.0x0.5	CERAMIC	1005
	VN065	1.6x1.0	CERAMIC	1608
	VN080	2.0x1.2	CERAMIC	2012
	VN140	Φ2.2/Φ1.4	CERAMIC	3216
	VN220	Φ3.6/Φ2.2	METAL	3225-4532

DECAN, SM series, CP45-NEO

PART No.	NAME	SPECIFICATION	MATERIAL	REMARK
J9055153B	TN02S	0.7x0.4	CERAMIC	0603
J9055154B	TN03S	1.1x0.6	CERAMIC	1005
J90551006A	CN020	Φ0.5/Φ0.15 (∞)	CERAMIC	0402
J9055133B	CN030	Φ0.5/Φ0.25	CERAMIC	0603
J9055134C	CN040	Φ0.75/Φ0.4	CERAMIC	1005
J9055136C	CN065	Φ1.2/Φ0.65	CERAMIC	1608
	CN080	Φ1.5/Φ0.9		
	CN110S	Φ2/Φ1.2	CERAMIC	2012
J9055138B	CN140	Φ2.2/Φ1.4	CERAMIC	2125,3216
J9055139B	CN220	Φ3.6/Φ2.2	METAL	3216
J9055258A	CN400	Φ6.0/Φ4.0	METAL	SOP,QFP
J9055218A	CN400N	Φ6.0/Φ4.0	METAL	SOP,QFP
J9055142B	CN750	Φ9.0/Φ7.5	METAL	SOP,QFP
J9055143B	CN1100	Φ12.7/Φ11.0	METAL	SOP,QFP



CP45F-V
CP40L-V
DP20 DISPENSER
DP50 DISPENSER



NXT M-III 24HEAD

PART No.	NAME	SPECIFICATION	MATERIAL	REMARK
2AGKNX005203	Φ0.3	Φ0.3	CERAMIC	
2AGKNX005303	Φ0.4	Φ0.4	CERAMIC	
2AGKNX005502	Φ0.5	Φ0.5	CERAMIC	
2AGKNX003106	Φ0.7	Φ0.7	CERAMIC	
	Φ0.8	Φ0.8	CERAMIC	
2AGKNX003504	Φ1.0	Φ1.0	CERAMIC	
2AGKNX001703	Φ1.3	Φ1.3	CERAMIC	
2AGKNX003703	Φ1.8	Φ1.8	CERAMIC	
2AGKNX003903	Φ2.5	Φ2.5	CERAMIC	



NXT-H08, H12

PART No.	NAME	SPECIFICATION	MATERIAL	REMARK
AA1AT00	Φ0.3	Φ0.4/Φ0.25	CERAMIC	
AA05600	Φ0.4	0.4x0.3	CERAMIC	
	Φ0.5	Φ0.55/Φ0.35x0.25	CERAMIC	
	Φ0.5C	0.55x0.45	CERAMIC	
AA05700	Φ0.7	Φ0.7/Φ0.38	CERAMIC	
AA05800	Φ1.0	Φ1.0/Φ0.7	CERAMIC	
AA20A00	Φ1.3	Φ1.3/Φ1.0	CERAMIC	
AA20B00	Φ1.8	Φ1.8	CERAMIC	
AA20C01	Φ2.5	Φ2.5	CERAMIC	
AA0WT00	Φ2.5G	Φ2.5	RUBBER	
AA20D00	Φ3.7	Φ3.7	CERAMIC	
AA18C00	Φ3.7G	Φ3.7	RUBBER	
AA20E00	Φ5.0	Φ5.0	METAL	
AA06300	Φ5.0G	Φ5.0	RUBBER	



NXT-H01, H02

PART No.	NAME	SPECIFICATION	MATERIAL	REMARK
AA0AS00	Φ1.0	Φ1.0/Φ0.7	CERAMIC	
AA06800	Φ1.3	Φ1.3/Φ1.0	CERAMIC	
AA0HL00	Φ1.8	Φ1.8	CERAMIC	
AA0HM00	Φ2.5	Φ2.5	CERAMIC	
AA08410	Φ2.5G	Φ2.5	RUBBER	
AA0HN00	Φ3.7	Φ3.7	METAL	
AA08500	Φ3.7G	Φ3.7	RUBBER	
AA0HR01	Φ5.0	Φ5.0	METAL	
AA07200	Φ5.0G	Φ5.0	RUBBER	
AA08000	Φ7.0	Φ7.0	METAL	
AA07310	Φ7.0G	Φ7.0	RUBBER	
AA08100	Φ10.0	Φ10.0	METAL	
AA07410	Φ10.0G	Φ10.0	RUBBER	
AA08200	Φ15.0	Φ15.0	METAL	
AA07510	Φ15.0G	Φ15.0	RUBBER	
AA08300	Φ20.0	Φ20.0	METAL	
AA07610	Φ20.0G	Φ20.0	RUBBER	



FUJI



NXT-H04

PART No.	NAME	SPECIFICATION	MATERIAL	REMARK
AA06W00	Φ1.0	Φ1.0/Φ0.7	CERAMIC	
AA06X00	Φ1.3	Φ1.3/Φ1.0	CERAMIC	
AA06Y00	Φ1.8	Φ1.8	CERAMIC	
AA06Z00	Φ2.5	Φ2.5	CERAMIC	
AA07F00	Φ2.5G	Φ2.5	RUBBER	
AA07A00	Φ3.7	Φ3.7	METAL	
AA00G00	Φ3.7G	Φ3.7	RUBBER	
AA07B00	Φ5.0	Φ5.0	METAL	
AA00H00	Φ5.0G	Φ5.0	RUBBER	
AA07C00	Φ7.0	Φ7.0	METAL	
AA07K00	Φ7.0G	Φ7.0	RUBBER	
AA07D00	Φ10.0	Φ10.0	METAL	
AA07L00	Φ10.0G	Φ10.0	RUBBER	

NXT-H04S

PART No.	NAME	SPECIFICATION	MATERIAL	REMARK
	Φ1.0	Φ1.0/Φ0.7	CERAMIC	
AA8TE00	Φ1.3	Φ1.3/Φ1.0	CERAMIC	
AA8VW00	Φ1.8	Φ1.8	CERAMIC	
AA8WX00	Φ2.5	Φ2.5	CERAMIC	
AA8XA00	Φ2.5G	Φ2.5	RUBBER	
AA93W00	Φ3.7	Φ3.7	METAL	
AA8XB00	Φ3.7G	Φ3.7	RUBBER	
AA93X00	Φ5.0	Φ5.0	METAL	
AA8XC00	Φ5.0G	Φ5.0	RUBBER	
AA93Y00	Φ7.0	Φ7.0	METAL	
AA8XD00	Φ7.0G	Φ7.0	RUBBER	
	Φ10.0	Φ10.0	METAL	
	Φ10.0G	Φ10.0	RUBBER	



NXT AIM-H08M

PART No.	NAME	SPECIFICATION	MATERIAL	REMARK
AA8DX00	Φ0.7	Φ0.7/Φ0.4	CERAMIC	
AA8LT00	Φ1.0	Φ1.0/Φ0.7	CERAMIC	
AA8DY00	Φ1.3	Φ1.3/Φ1.0	CERAMIC	
AA8LW00	Φ1.8	Φ1.8	CERAMIC	
AA8LX00	Φ2.5	Φ2.5	CERAMIC	
AA8ME00	Φ2.5G	Φ2.5	RUBBER	
AA8LY00	Φ3.7	Φ3.7	METAL	
AA8MF00	Φ3.7G	Φ3.7	RUBBER	
AA8LZ00	Φ5.0	Φ5.0	METAL	
AA8MG00	Φ5.0G	Φ5.0	RUBBER	
AA8MA00	Φ7.0	Φ7.0	METAL	
AA8MH00	Φ7.0G	Φ7.0	RUBBER	
AA8MB00	Φ10.0	Φ10.0	METAL	
AA8MK00	Φ10.0G	Φ10.0	RUBBER	



CP7, CP8

PART No.	NAME	SPECIFICATION	MATERIAL	REMARK
ADCPH-9510	Φ0.4	Φ0.4 (8mm DISK)	METAL	
ADCPH-9520	Φ0.7	Φ0.7 (8mm DISK)	METAL	
ADCPH-9530	Φ1.0	Φ1.0 (8mm DISK)	METAL	
ADCPH-9540	Φ1.3	Φ1.3 (8mm DISK)	METAL	
ADCPH-9550	Φ1.8	Φ1.8 (16mm DISK)	METAL	
ADCPH-9560	Φ2.5	Φ2.5 (16mm DISK)	METAL	
ADCPH-9570	Φ3.75	Φ3.75 (16mm DISK)	METAL	

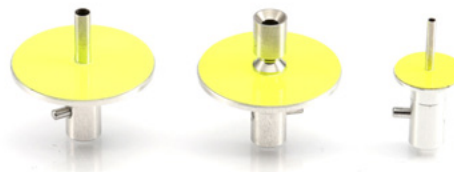

CP6

PART No.	NAME	SPECIFICATION	MATERIAL	REMARK
AWPH-9720	Φ0.4	Φ0.4 (12mm DISK)	METAL	
AWPH-9514	Φ0.7	Φ0.7 (12mm DISK)	METAL	
AWPH-9524	Φ1.0	Φ1.0 (12mm DISK)	METAL	
AWPH-9534	Φ1.3	Φ1.3 (12mm DISK)	METAL	
AWPH-9554	Φ1.8	Φ1.8 (12mm DISK)	METAL	
AWPH-9563	Φ2.5	Φ2.5 (16mm DISK)	METAL	
AWPH-9572	Φ3.75	Φ3.75 (16mm DISK)	METAL	
AWPH-9583	Φ2.5	Φ2.5 (20mm DISK)	METAL	
AWPH-9602	Φ3.75	Φ3.75 (20mm DISK)	METAL	
AWPH-9612	Φ5.0	Φ5.0 (20mm SQ DISK)	METAL	

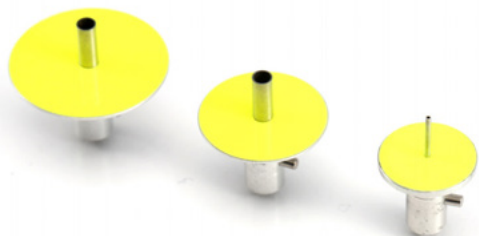

CP4

PART No.	NAME	SPECIFICATION	MATERIAL	REMARK
AMPH-8710	Φ0.7	Φ0.7 (12mm DISK)	METAL	
AMPH-8720	Φ1.0	Φ1.0 (12mm DISK)	METAL	
AMPH-8730	Φ1.3	Φ1.3 (12mm DISK)	METAL	
AMPH-8740	Φ1.8	Φ1.8 (12mm DISK)	METAL	
AMPH-8750	Φ2.5	Φ2.5 (12mm DISK)	METAL	
	Φ1.3	Φ1.3 (25mm DISK)	METAL	
AMPH-8760	Φ2.5	Φ2.5 (25mm DISK)	METAL	
AMPH-8770	Φ3.75	Φ3.75 (25mm DISK)	METAL	
AMPH-8780	Φ5.0	Φ5.0 (25mm DISK)	METAL	

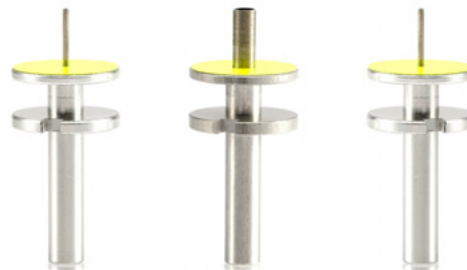

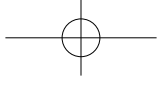

FUJI

XP142, XP143(HEXAGON REFLECTOR)



PART No.	NAME	SPECIFICATION	MATERIAL	REMARK
ADNPN-8306	Φ0.4	Φ0.4/Φ0.25	CERAMIC	
ADNPN-8310	Φ0.7	Φ0.7/Φ0.38	CERAMIC	
ADNPN-8230	Φ1.0	Φ1.0/Φ0.65	CERAMIC	
ADNPN-8240	Φ1.3	Φ1.3/Φ0.9	CERAMIC	
ADNPN-8250	Φ1.8	Φ1.8/Φ1.2	CERAMIC	
ADNPN-8260	Φ2.5	Φ2.5/Φ2.0	CERAMIC	
ADNPN-8276	Φ3.7	Φ3.75/Φ3.2	CERAMIC	

XP242, XP243, XP341

PART No.	NAME	SPECIFICATION	MATERIAL	REMARK
ADEPN-8550	Φ1.3	Φ1.3/Φ0.9	CERAMIC	
ADEPN-8560	Φ1.8	Φ1.8/Φ1.2	CERAMIC	
DEPN-3060	Φ2.5	Φ2.5/Φ2.0	CERAMIC	
DEPN-3070	Φ3.7	Φ3.75/Φ3.2	CERAMIC	
DEPN-3080	Φ5.0	Φ5.0	METAL	
DEPN-3090	Φ7.0	Φ7.0	METAL	
DEPN-3100	Φ10.0	Φ10.0	PLASTIC	



XP 141
QP242 INDEX NOZZLE
QP242 SINGLE NOZZLE
IP-3 series
GL-II / GL-V



KE 2010~2040

PART No.	NAME	SPECIFICATION	MATERIAL	REMARK
E3608-729-0A0	500	1.0x0.5/2-HOLE	METAL	1005
E3600-729-0A0	501	Φ0.7/Φ0.2	METAL	0603
E3601-729-0A0	502	Φ0.7/Φ0.4	METAL	1005
E3602-729-0A0	503	Φ1.0/Φ0.6	METAL	1608
E3603-729-0A0	504	Φ1.5/Φ0.9	METAL	2125
E3604-729-0A0	505	Φ3.5/Φ1.7	PAD	
E3605-729-0A0	506	Φ5.0/Φ3.2	PAD	
E3606-729-0A0	507	Φ8.5/Φ5.0	PAD	
E3607-729-0A0	508	Φ9.5/Φ8.0	PAD	
JK2024510	510	Φ1.5	METAL	MELF
JK2024511	511	Φ2.0	METAL	MELF



KE 2050~2080, FX-1R/3R

PART No.	NAME	SPECIFICATION	MATERIAL	REMARK
E3608-729-0A0	500	1.0x0.5/2-HOLE	METAL	1005
E3600-729-0A0	501	Φ0.7/Φ0.2	METAL	0603
E3601-729-0A0	502	Φ0.7/Φ0.35	METAL	1005
E3602-729-0A0	503	Φ1.0/Φ0.6	METAL	1608
E3603-729-0A0	504	Φ1.5/Φ1.0	METAL	2125
E3604-729-0A0	505	Φ3.5/Φ1.7	PAD	
E3605-729-0A0	506	Φ5.0/Φ3.2	PAD	
E3606-729-0A0	507	Φ8.5/Φ5.0	PAD	
E3607-729-0A0	508	Φ9.5/Φ8.0	PAD	



**KE730~760
KD770 DISPENSER
KD775 DISPENSER**



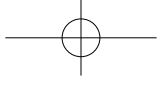

F-130



PART No.	NAME	SPECIFICATION	MATERIAL	REMARK
A-1081-496-B	AF06021(F1)	Φ0.6/Φ0.25	CERAMIC	0603
A-1081-494-C	AF06042(F1)	Φ0.7/Φ0.4	CERAMIC	0603
A-1081-495-B	AF10071(F1)	Φ1.0/Φ0.7	CERAMIC	1005
A-1081-951-C	AF12082(F1)	Φ1.4/Φ0.9	CERAMIC	1608
A-1081-950-B	AF25200(F1)	Φ2.5/Φ2.0		2125
A-1081-952-B	AF40300(F1)	Φ4.0/Φ3.0		
A-1081-953-B	AF60400(F1)	Φ6.0/Φ4.0		

E-1000

PART No.	NAME	SPECIFICATION	MATERIAL	REMARK
A-8417-333	AF05021	Φ0.45/Φ0.25	CERAMIC	0402
A-8417-334	AF06040	Φ0.6/Φ0.38	CERAMIC	0603
A-8417-336	AF08050	Φ0.8/Φ0.5	CERAMIC	1005
A-8417-337	AF10070	Φ0.9/Φ0.65	CERAMIC	1005,1608
A-8417-339	AF12080	Φ1.3/Φ0.9	CERAMIC	1608
A-8417-340	AF25200	Φ2.5/Φ2.0		2125
A-8417-341	AF40300	Φ4.0/Φ3.0		
A-8417-342	AF60400	Φ6.0/Φ4.0		



G200MK E-2000, SI-F209 SS-H, SS-H2F

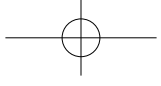

900 series (ORG.)(12HEAD)

PART No.	NAME	PART No.	NAME	PART No.	NAME
00322603	901	00325972	920	00322591	937
00348186	902	00325970	921	00322592	938
00322602	904	00324996	923	00322593	939
00345031	911	00321866	924	00330533	951
00345020	913	00333652	925	00330534	952
00321861	914	00346522	932	00330535	953
00321862	915	00346523	933	00330536	954
00321863	917	00327810	934	00330537	955
00321864	918	00346524	935	00330538	956
00321867	919	00352353	936		



1000 series (ORG.)(20HEAD)

PART No.	NAME	PART No.	NAME
03013307-01	1001	03013425-01	1033
03015869-01	1003	03013103-01	1034
03015840-01	1004	03015194-01	1035
	1005	03014331-01	1036
03015854-01	1006	03014336-01	1133
03013300-01	1011	03015384-01	1135
03013303-01	1014	03015222-01	1235
03014327-01	1032		



400 series
500 series
700 series
2000 series
3000 series



CASIO

YCM-7000, 7700, 7800, 8800

PART No.	NAME	SPECIFICATION	MATERIAL	REMARK
H03/H3M	H03/H3M	0.4×0.5/Φ0.25	CERAMIC	0603
HS1/H1M	HS1/H1M	Φ0.7/Φ0.38	CERAMIC	1005
H2/H2M	H2/H2M	Φ1.1/Φ0.65	CERAMIC	1608
H06	H06	Φ1.2/Φ0.9	CERAMIC	
H7	H7	Φ2.0/Φ1.4	CERAMIC	3216
H07	H07	Φ3.0/Φ2.3		
H21 MELF	H21 MELF	Φ0.8/Φ0.45	CERAMIC	MELF
H22 MELF	H22 MELF	Φ1.2/Φ0.9	CERAMIC	MELF
H23 MELF	H23 MELF	Φ2.0/Φ1.4	CERAMIC	MELF
H24 MELF	H24 MELF	Φ3.0/Φ2.3		MELF
H31	H31	Φ5.0/Φ3.0		
H32	H32	Φ6.0/Φ4.0		
H33	H33	Φ9.0/Φ7.0		
H34	H34	Φ11.0/Φ9.0		
H35	H35	Φ13.0/Φ11.0		
H36	H36	Φ18.0/Φ16.0		
T7	T7	Φ2.0/Φ1.4	CERAMIC	
T07	T07	Φ3.0/Φ2.3		
T06	T06	Φ1.6/Φ1.0	CERAMIC	
T21 MELF	T21 MELF	Φ0.8/Φ0.45	CERAMIC	
T22 MELF	T22 MELF	Φ1.2/Φ0.9	CERAMIC	
T23 MELF	T23 MELF	Φ2.1/Φ1.4	CERAMIC	
T24 MELF	T24 MELF	Φ3.1/Φ2.6		
T31	T31	Φ5.0/Φ3.0		
T32	T32	Φ6.0/Φ4.0		
T33	T33	Φ9.0/Φ7.0		
T34	T34	Φ11.0/Φ9.0		
T35	T35	Φ13.0/Φ11.0		
T36	T36	Φ18.0/Φ16.0		



YCM-3300, 3500

PART No.	NAME	SPECIFICATION	MATERIAL	REMARK
NP1	NP1	Φ1.2/Φ0.4		
NP2	NP2	Φ1.2/Φ0.6		
P2	P2	Φ1.2/Φ0.4	CERAMIC	
P7	P7	Φ3.0/Φ1.0		
04	04	Φ0.8/Φ0.5	CERAMIC	
05	05	Φ1.2/Φ0.9	CERAMIC	
06	06	Φ1.6/Φ1.2	CERAMIC	
07	07	Φ3.0/Φ2.3		
031	031	Φ5.0/Φ2.5		
032	032	Φ7.0/Φ4.0		
T34	Φ11/Φ9			
T35	Φ13/Φ11			
T36	Φ18/Φ16			



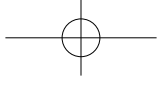

GENERAL TYPE (MX100~400, MPS-1010~1030)

PART No.	NAME	SPECIFICATION	MATERIAL	REMARK
21003-67190	0603	Φ0.5/Φ0.25	CERAMIC	0603
21003-61000-005B	A(BSE)	Φ0.7/Φ0.4	CERAMIC	1005
21003-61000-005	A(ORG)	Φ1.0/Φ0.5	CERAMIC	1005
21003-62000-105	B	Φ1.2/Φ0.7	CERAMIC	1608~3216
21003-63000-005	C	Φ2.0/Φ1.2	CERAMIC	2012~2125
21003-64000-005	D	Φ3.0/Φ2.0		3216
21003-65000-005	E	Φ6.0/Φ4.5		IC,QFP
21003-66000-105	P2-1	Φ8.8/Φ6.5		QFP,PLCC
21003-66190-000	P2-1-SO1	Φ8.0	RUBBER	
21003-66290-000	P2-1-SO2	Φ6.0	RUBBER	
21003-66390-000	P2-1-SO3	Φ17.0	RUBBER	
21003-67200-000	H-4C-2	0.7×0.4		1005



PRECISION(QP)(MX240, MPS-1020AP)

PART No.	NAME	SPECIFICATION	MATERIAL	REMARK
21243-61090-003	A	Φ1.0/Φ0.5	CERAMIC	1005
21243-62090-100	B	Φ1.2/Φ0.7	CERAMIC	1608
21243-63090-000	C	Φ2.0/Φ1.2	CERAMIC	2012,2125
21243-64090-000	D	Φ3.0/Φ2.0		3216
21243-65090-000	E	Φ6.0/Φ4.5		IC,QFP
21243-65990-001	E-S09	18×2	PAD	
21243-65990-100	E-S09-1	18×4	PAD	
21243-65990-000	E-S0G	17×2	PAD	
21243-66090-000	P2-1	Φ10.0/Φ8.5		QFP,PLCC
21243-66190-000	P2-1-SO1	Φ8.0	RUBBER	
21243-66290-000	P2-1-SO2	Φ6.0	RUBBER	
21243-66490-000	P2-1-SO4	Φ17.0	RUBBER	





SANYO



TCM-3000, 3000Z, 110J

PART No.	NAME	SPECIFICATION	MATERIAL	REMARK
	0603	Φ0.6/Φ0.3	CERAMIC	0603
	1005	Φ1.2/Φ0.7	CERAMIC	1005
630 052 9586	Z81	Φ0.6/Φ0.4		1005
630 052 9517	Z11	Φ0.9/Φ0.7		1608
630 052 9579	Z71	Φ1.3/Φ0.9		2125
630 052 9524	Z21	Φ1.8/Φ1.1		3216
630 052 9548	Z41	Φ3.0/Φ2.0		IC/S
630 052 9531	Z31	Φ6.0/Φ5.0		IC/L
630 052 9555	Z52	Φ1.3/Φ0.9		S MELF
630 052 9562	Z62	Φ2.5/Φ1.2		L MELF

TDM-3000 DISPENSER

PART No.	NAME	SPECIFICATION	MATERIAL	REMARK
630 071 6085	NS102	Φ0.7/Φ0.4 P=0.9		
630 068 1338	NM200	Φ0.8/Φ0.5 P=1.3		
630 093 9187	NM203	Φ0.8/Φ0.5 P=1.0		
630 074 7782	NM204	Φ0.9/Φ0.6 P=1.4		
630 068 1376	NL300	Φ1.3/Φ0.96 P=1.8		
630 070 9421	NL302	Φ1.3/Φ0.96 P=2.0		
630 067 5757	NP401	Φ1.3/Φ0.96 P=1.5		
630 069 0347	NP404	Φ0.8/Φ0.5 P=1.0		

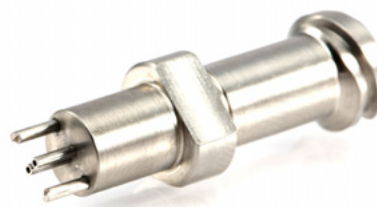

**TCM-1000 series
TCM-822 series
TIM-5000 series
TDM-60 DISPENSER
TDM-1000 DISPENSER**



ASSEMBLEON AX301, AX501

PART No.	NAME	SPECIFICATION	MATERIAL	REMARK
9466 027 71011	CP L1		METAL	0402
9466 027 71081	CP L2		METAL	0603-1005
9466 027 71131	CP L3		METAL	1005-1608
9466 027 71171	CP L4		METAL	1608-3216
9466 027 71201	L5			1206-SO
9466 027 71251	L6		MELF	
9466 027 71301	L7			
9466 027 71351	L8			
9466 027 71551	V3			
9466 027 71601	V4			
9466 027 71651	V5			
9466 027 71701	V6			
9466 027 71751	V7			
9466 027 71801	V8			

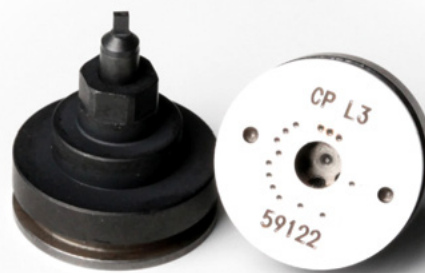

TOPAZ-XII, OPAL-XII(YV100X, YV180X)

PART No.	NAME	SPECIFICATION	MATERIAL	REMARK
	0603	0.35×0.65	CERAMIC	0603
KV8-M7710-A0X	71A	0.7×0.8 (X)	CERAMIC	1005
KV8-M7720-A0X	72A	1.0×1.7 (X)	CERAMIC	1608
KV8-M7730-A1X	73A	Φ4.0/3.0×2.0	METAL	IC
KV8-M7740-A1X	74A	Φ8.0	O-ring	SOP, QFP
KV8-M7760-A1X	76A	3.0×2.0	METAL	MELF
KV8-M77WL-A00	79A	Φ1.2/Φ0.7	CERAMIC	1608
KV8-M71U1-002	71F	0.6×0.8	CERAMIC	1005
KV8-M71N2-A00	72F	1.0×1.7	CERAMIC	1608
KV8-M71N3-A00	73F	Φ4.0/3.0×2.0	METAL	IC
KV8-M7WL-A00	79F	Φ1.2/Φ0.7	CERAMIC	1608



MG-3, MC-1, MC-12 (YS12, YS24, YG12, YG24)
MG-1, MG-8 (YG100B, YG100R, YG88R)
MG-2 (YG200, YG300)
EMERALD-XII (YV88XG, YV88XF)
TOPAZ, EMERALD (YV100II, YVL88)



ENC-12S, ENC-24S (NOZZLE CLEANER)



Nozzle cleaner	Name	ENC-12S	ENC-24S
Nozzle head	Quantity	12	24
Compressed air	Type	clean air	clean air
	Pressure	7kgf/cm ²	7kgf/cm ²
Cleaning water	Type	distilled water	distilled water
	Cleaning fluid amount	4L	6L
Input power supply	Voltage	DC100~250V	DC100~250V
	Plug	3 PIN(with ground)	3 PIN(with ground)
	Cable length	1.6m	1.6m
	Power consumption	200W	200W
Size	550(L) × 420(W) × 480(H)		
Weight	42.5kg		

Cleaning Process

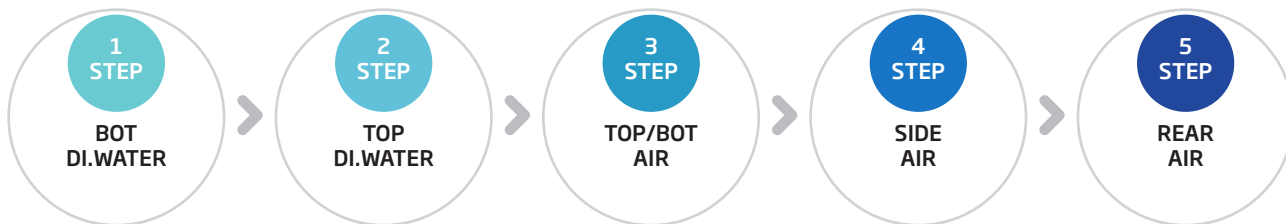

Features of Nozzle Cleaner

- The effect of Carbon reduction by using distilled water
- Possible to clean 12/24 nozzle at the same time
- Easy to operate with touch panel
- Reduce the time to change the nozzle by using the nozzle holder

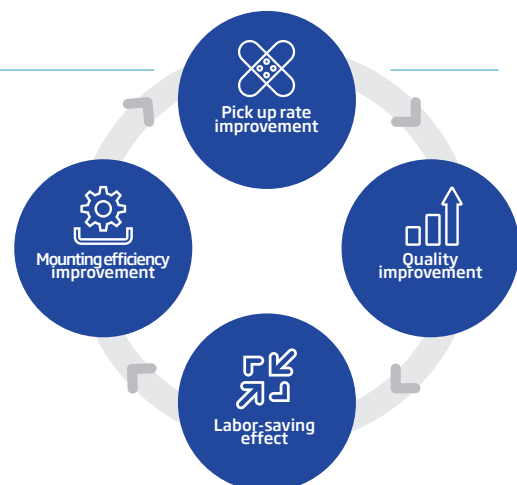

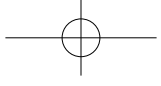

ENI-12AP, ENI-124MP(NOZZLE INSPECTION)



◦ **ENI-12AP :**
400(L)*300(W) *500(H) 9 kg

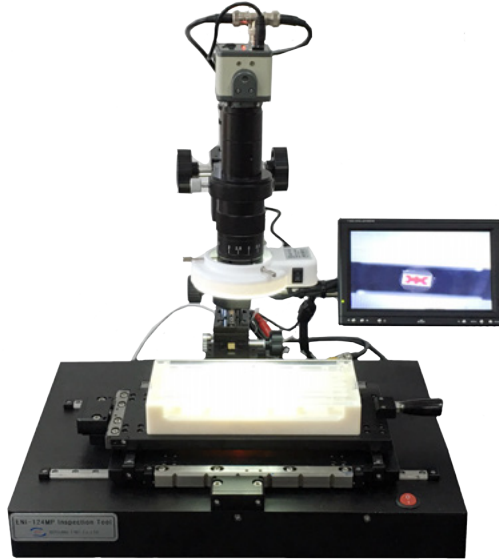

◦ **ENI-124MP :**
430(L)*316(W) *500(H) 11 kg

Our microscope, which has a single zoom head, provides clear images, 3D effect, sufficient working distance and wide sight with unique light focus and excellent depth of field technology. In addition, it comes with high-definition color CCD and LCD monitor.

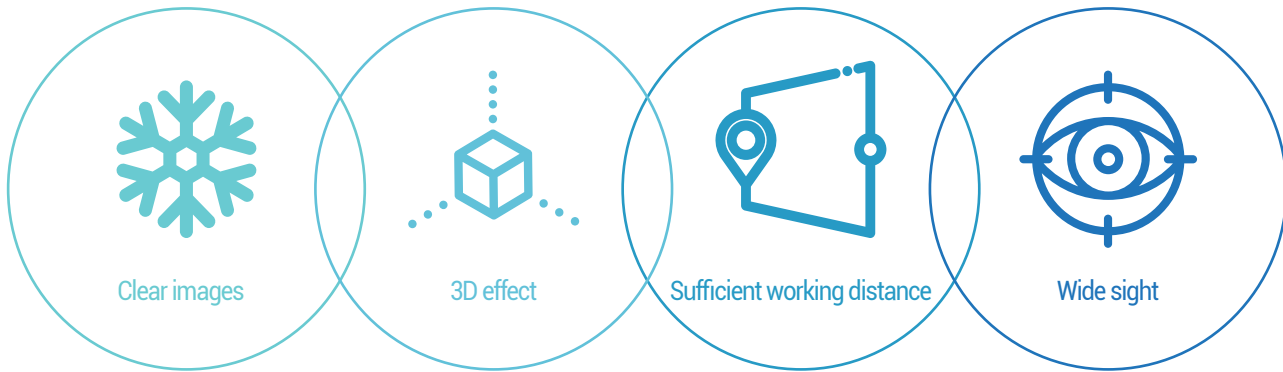

Nozzle Inspection System

NAME	ENI -12AP	ENI -124MP
Dimension	Nozzle Inspection System	Nozzle Inspection System
Size	400(L) X 300(W) X 500(H)	430(L) X 316(W) X 500(H)
CCD Camera	1/3" sony	1/3" sony
Monitor	7 inch	7 inch
Optical Magnification	0.7 X ~ 4.5X	0.7 X ~ 4.5X
Working Distance	110mm	110mm
Maximum Magnification	Max 130 times	Max 130 times
Pneumatic	Min 4kgf/cm ²	
Voltage	110V/60Hz or 220V/50Hz	110V/60Hz or 220V/50Hz
Weight	9kg	12kg
Image Store	Possible(PC)	Possible(PC)

SC-ER360W, SC-ER610F, SC-ER610FA(ROLL PAPER CLEANER)



- **SC-ER360WE :**
850(L)*650(W) *1100(H)
100 kg
- **SC-ER610F :**
850(L)*850(W) *1100(H)
130 kg

Merits



Cost-effective
Comparison of running cost for 1 year after 5 times' recycling

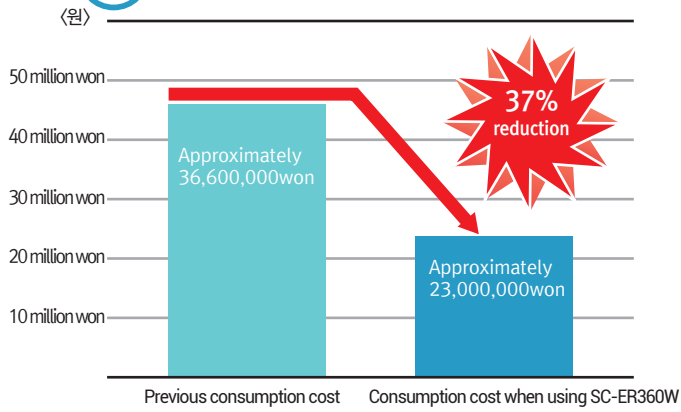

Cost reduction (calculated per year)...
approximately 3,192,750won*¹

* Condition1: Paper cost<6,000won<18m>, 26 units to be used per day, 20days' operation for 1 month
Unit cost of industrial waste treatment: 100won<calculated per 1>, cleaning liquid: when using a glycol type



Environmentally friendly
Reduction of Co2 emission caused by incineration (calculated)

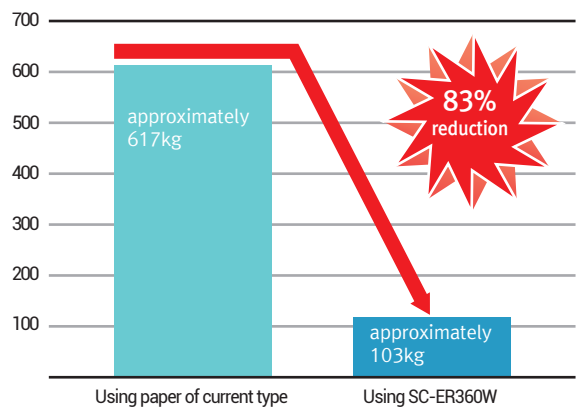

CO2 reduction(calculated per year)...
approximately 514kg*²

* Condition2: The above is one of advantages and the results can change according to conditions.

Before & After

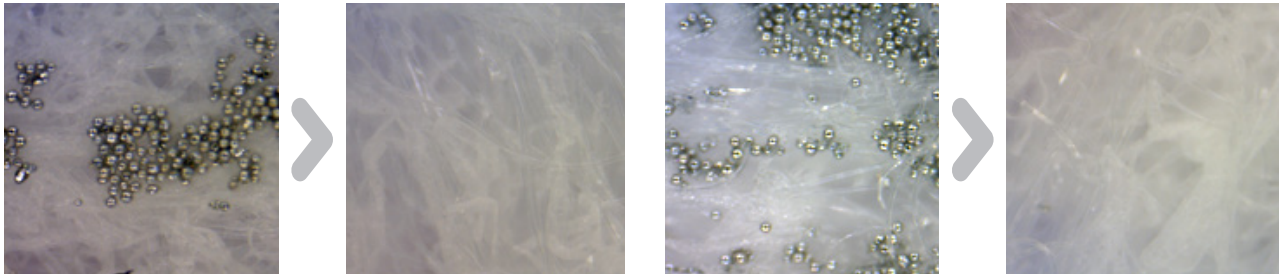

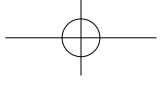

NOZZLE RACK, SQUEEGEE RACK



◦ **Nozzle & Squeegee Rack :**
1200(L)*400(W) *1100(H)
60 kg

◦ **Nozzle Rack :**
620(L)*400(W) *1100(H)
40 kg



Improved System

Standardized cleanup 8 PCS Squeegee input Possible to Customized

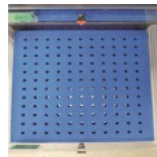

Nozzle Storage

Prevention broken 2,640 PCS keeping (11 X 12) X20 Drawer) Easy to check inventory



Stability

Precision processing Good storage Any size possible



Bigger Space

20 PCS of Draver Easy to open Defective management for nozzle



Convenience

Larger storage Storage related tools Improved of operation



Management

Locking door Durability Rack Easy to clean

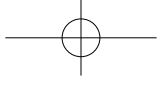

Free PCB Loader/Unloader

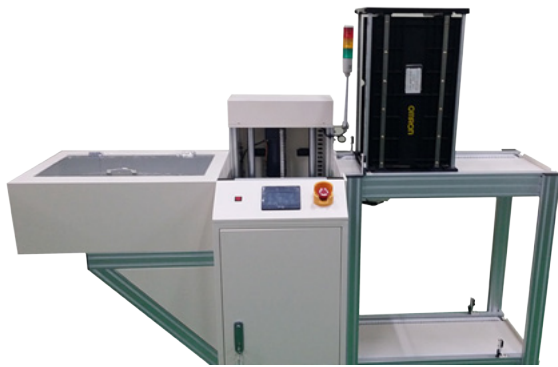

1. 필요성 Necessity

- ①최근 증가하는 led smt작업시 unloader 교체작업으로 인한 불합리 .
In case of led smt work, which has been increased recently, irrationality due to replacement of unloader
- ②그에따른 기존 unloader의 한계.
Restrictions of the current unloader according to it.

2.특징 Features

- ①최대길이610mm까지 대응가능(기존M size magazine사용).
Can cope with the maximum size of 610mm (for the current M size magazine)
- ②기존 M-size의magazine및 다양한 크기의 PCB적재 및 이송가능.
Can load and transport the current magazine of M-size and various sizes of PCB
- ③별도 사양의 unloader 설비 중복 투자 방지
Can avoid duplicate investment in unloader facility with different specifications

BASIC SPECIFICATION		
ITEM	PCB UNLOADER	
SIZE	1920 x 823 x 1720	
UNIT PART	CHAIN CONVEYOR	PLC
	GRARED MOTOR	TOUCH(4.3")
	AIR CYLINDER	
	PCB WIDTH(50mm~250mm)	
	PCB LENGTH 650mm	
POWER SOURCE	AC220V x 1 x 60Hz	
AIR SUPPLY	5Kgf/cm	
REMARK		

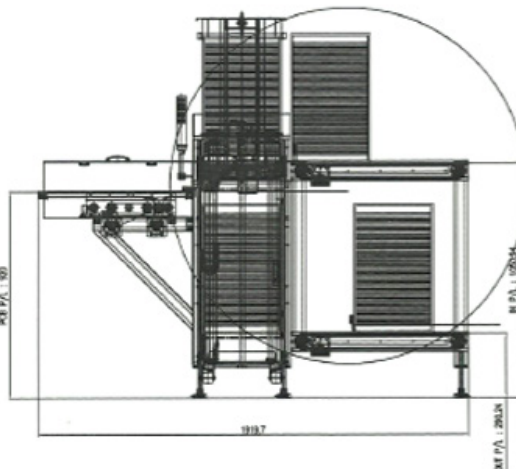
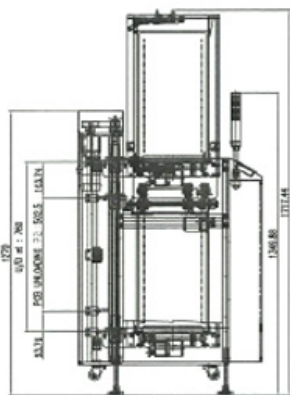
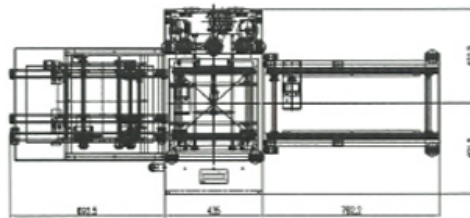

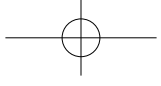

ETC PARTS

FILTER

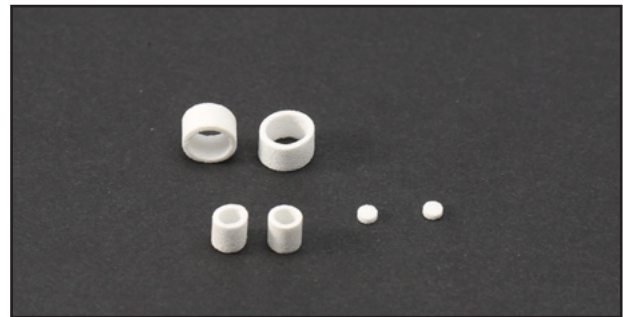

MAKER	MACHINE	PARTS NO.	REMARKS	
PANASONIC	CM602/402	N610071334AA	HOLDER FILTER	
	NPM-8H/16H	N610009394AC	NOZZLE FILTER	
	CM20F/DT401	N610009394AB	NOZZLE FILTER	
	NPM	N510054846AA	ELEMENT FILTER	
	MSR	1046710117	NOZZLE FILTER	
	MV-SERIES		N421PTFBF	SOFT FILTER
			N421PTFB30	HARD FILTER
			1042710035	NOZZLE FILTER
			1023710012	NOZZLE FILTER
		MSH2/3		NOZZLE FILTER
		MMC/MCF		NOZZLE FILTER
		MSF , BM	1080729975	NOZZLE FILTER
	FUJI	CP6	WPH-2030	
		CP7	DCPH-0630	
NXT 4HEAD		XH00400		
NXT 8HEAD		XH00800		
NXT		XH00560		
NXT		XH00940		
SAMSUNG	SM471/481			
	SM320	J7458002A		
	CP45FV	H3022L		
	CP40LV	H3022T		
JUKI	KE2000-SERIES	E3052729000		
	KE2050-2080			
YAMAHA	YV100X	K46-M8527-C00		
	YS12/24			
HITACHI	GXH1/3 , Σ-G4/G5			

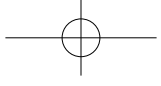

ETC PARTS

HEAD SHAFT & HOLDER



MAKER	MACHINE	REMARKS
PANASONIC	CM402-8H	HOLDER/SHAFT
	CM602-12H	HOLDER/SHAFT
	NPM-8H	HOLDER/SHAFT
	NPM-16H	HOLDER/SHAFT
YAMAHA	YV100X	HEAD SHAFT
	YV100II	HEAD SHAFT
	YS12/24	HEAD SHAFT
SAMSUNG	CP40LV	BELL NOZZLE
	CP45FV	BELL NOZZLE
	SM-Series	BELL NOZZLE
JUKI	KE2050~2080	HEAD SHAFT

CUTTER

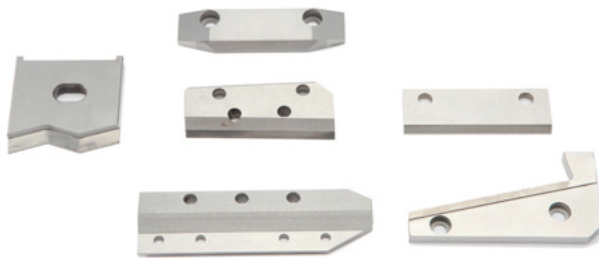

MAKER	MACHINE	REMARKS
PANASONIC	MSR	MOVING / FIXED
	MV-SERIES	MOVING / FIXED
	MSH2/3	MOVING / FIXED
KME	CM88S-M	MOVING / FIXED
	CM88C-M	MOVING / FIXED
FUJI	CP743	MOVING / FIXED
	CP732	MOVING / FIXED
	CP6	MOVING / FIXED
SANYO	TCM3000	MOVING / FIXED

BACK UP RUBBER BLOCK & MULTI MANUAL BACK UP BLOCK



BACK UP RUBBER BLOCK

NAME	PART DESCRIPTION	REMARKS
BACK UP RUBBER	44*125	HARD/SOFT
BACK UP RUBBER BLOCK	DATA for ON(SMT machine)	

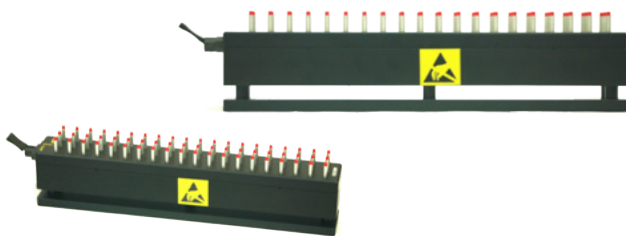

MULTI-MANUAL BACK UP BLOCK

NAME	PART DESCRIPTION	REMARKS
MBU250	250mm(L)*42mm(W)*Min.52mm(H)	
MBU300	300mm(L)*42mm(W)*Min.52mm(H)	Stroke type
MBU350	350mm(L)*42mm(W)*Min.52mm(H)	

ETC PARTS

SPLICE TOOL SET

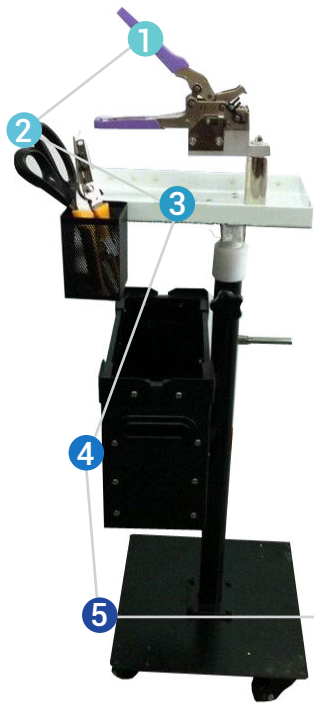

Purpose

Ideal for splicing SMT component tape on the fly to dramatically reduce downtime on pick and place equipment.

Especially cassette Tape Reel and new tape can be connected through splice lip by non stop. " Single Type : Paper or Emboss Single(Carrier Tape) with : 8mm~24mm"

Features

- A) Width : Paper or Emboss "8mm~24mm"
- B) Thickness : Paper or Emboss 0.3T~1.0T

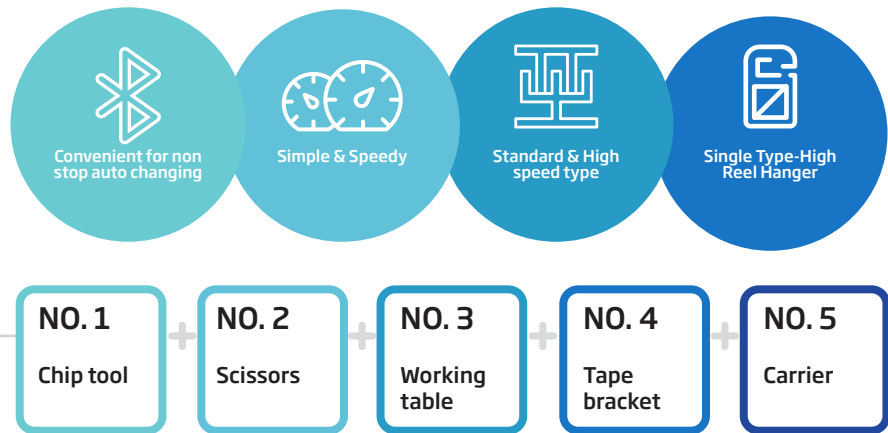

JOINT TAPE



NAME	PART DESCRIPTION	REMARKS
JOINT TAPE	8mm YELLOW	BOX(500EA)
JOINT TAPE	12mm YELLOW	BOX(500EA)
JOINT TAPE	16mm YELLOW	BOX(500EA)
JOINT TAPE	24mm YELLOW	BOX(500EA)
JOINT TAPE	8mm BLUE	BOX(500EA)
JOINT TAPE	12mm BLUE	BOX(500EA)
JOINT TAPE	16mm BLUE	BOX(500EA)

SPLICE CLIP



NAME	PART DESCRIPTION	REMARKS
SPLICE CLIP	COPPER multi	BOX(4,000EA)
SPLICE CLIP	COPPER piece	BOX(4,000EA)

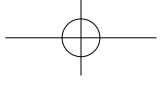

ETC PARTS

SMT SQUEEGEE HOLDER & BLADE



NAME		
MPM	SJ	PANASONIC
JUKI	DEK	YAMAHA
SAMSUNG	HITACHI	ESE

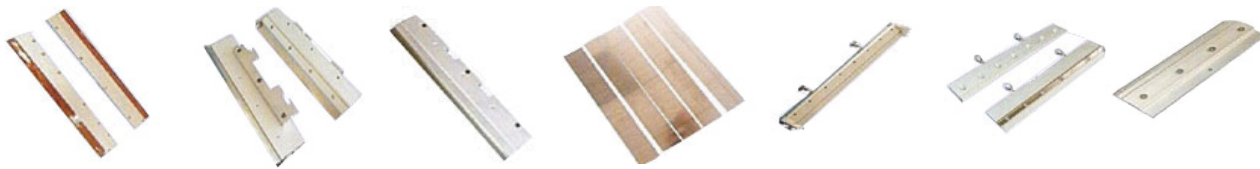

DEK BOARD CLAMP & BOM SQUEEGEE USC



DEK BOARD CLAMP

NAME	PART DESCRIPTION
DEK PRINTER	BOARD CLAMP 250mm
DEK PRINTER	BOARD CLAMP 340mm
DEK PRINTER	BOARD CLAMP 380mm
DEK PRINTER	BOARD CLAMP 500mm



BOM SQUEEGEE USC

NAME	PART DESCRIPTION
193199 BOM SQUEEGEE USC	300mm
193202 BOM SQUEEGEE USC	400mm
193205 BOM SQUEEGEE USC	520mm

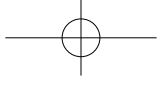

ETC PARTS

SMT FEEDER PARTS



SMT MOUNTER FEEDER



FUJI



PANASONIC

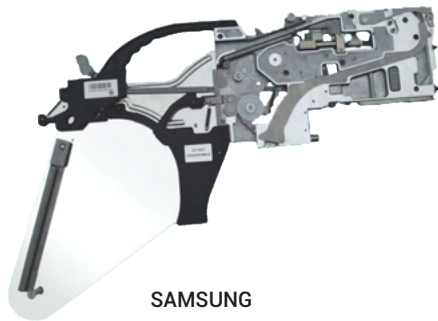

SAMSUNG



YAMAHA

ETC SERVICE(MACHINE & EQUIPMENT)

SOLDER PASTE KEEPER



- Because it includes a touch screen taht can be conveniently operated. everyone can operate it with ease.
- It classifies whether the present operation is proceeding correctly or not by colors using a 3-color LED.
- It is possible to purchase equipment separately, as we sell label printers separately. (Option to purchase label printers)
- It can store solder paste safely through the automatic locking function.
- It can manage 2 kinds of solder paste in 1 piece of equipment by setting groups.

DATE	2012-10-25	CH	01
P.Time	09:00:21	P.Temp	20.4°C
Start Time	08:59:03	Run Time	00:01:18

Specifications

	DK-5 (5door)	DK-10 (10door)
Power Supply	220V AC 50/60Hz	220V AC 50/60Hz
Dimention	500(W) X 340(D) X 350(H)mm	500(W) X 520(H)mm
Weight	About 15kg	About 25kg
Timer Setting	1Seconds ~ 3Hours	
Capacity	65X 75H (It is possible to manufacture separate containers)	

ETC SERVICE(MACHINE & EQUIPMENT)

UI-351A6 [wave checker]

Available in PbFree
Wave Checker

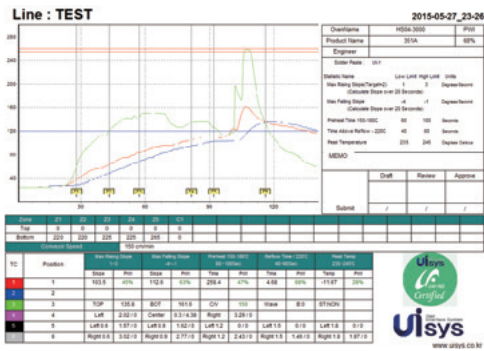

UI-351A6 [wave checker]

Available in PbFree
Wave Checker

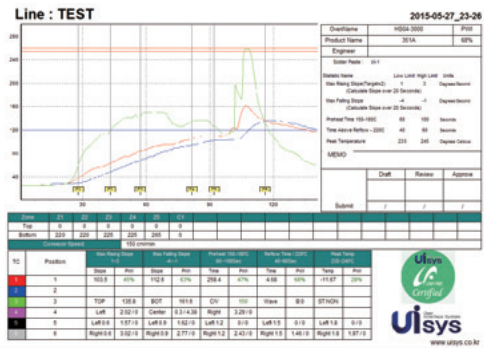

UI-O210KA [In-Line O₂ Analyzer]

Available in PbFree
In-Line O₂ Analyzer



Patent No. 10-1102986

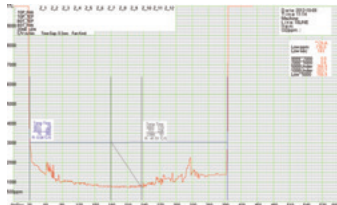

UI-HICAM [reflow inline camera]

reflow inline camera

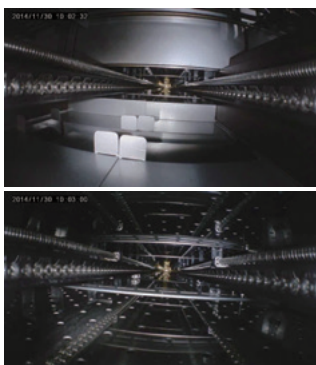

ETC SERVICE(MACHINE & EQUIPMENT)

UI-501 [rttps - reflow]

Available in PbFree
Real Time Temperature
Profile System

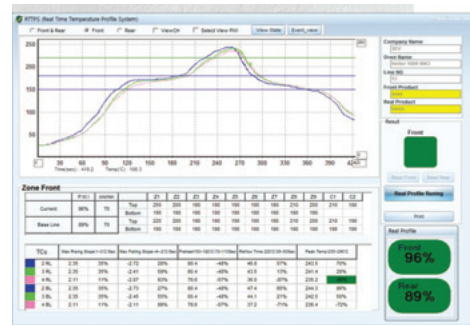
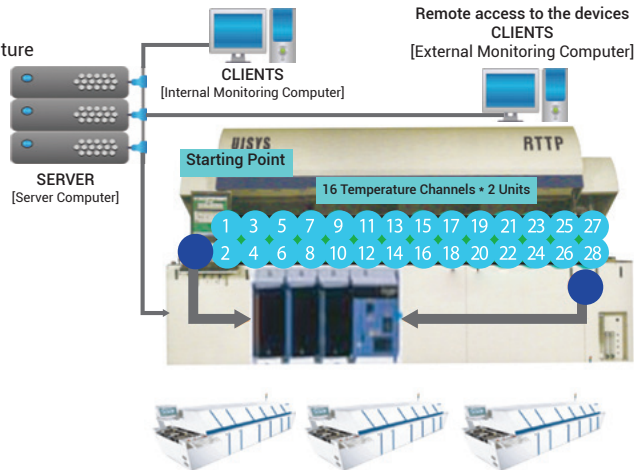

UI-510 [rttps - wave]

Available in PbFree
Real Time Temperature
Profile System

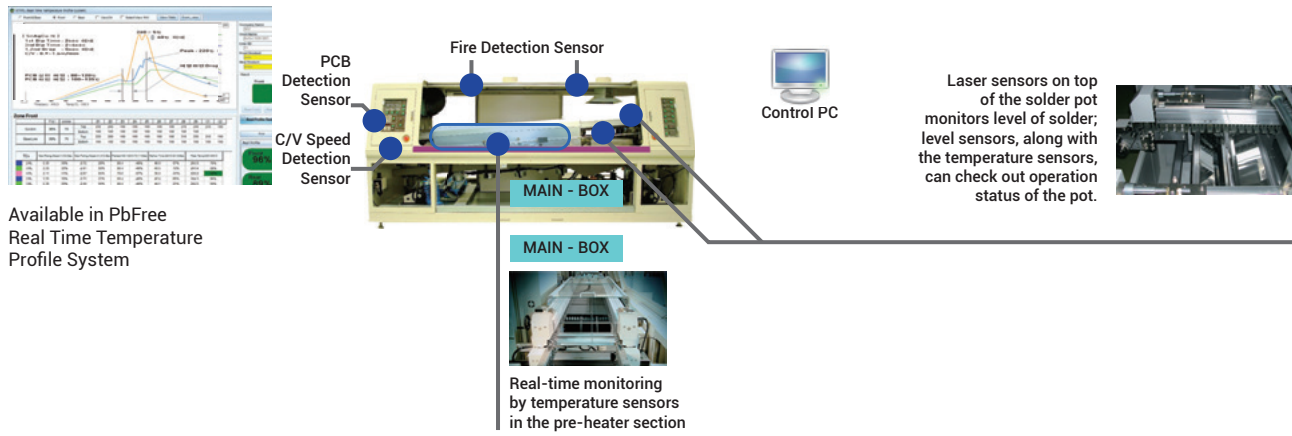

UI-301A6 [reflow checker]

Available in PbFree
Reflow Checker

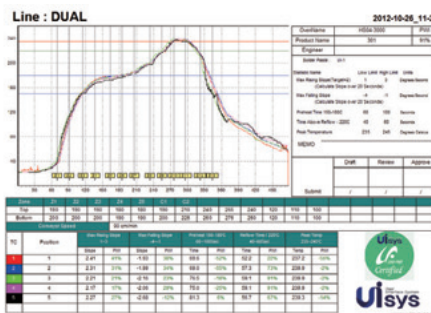
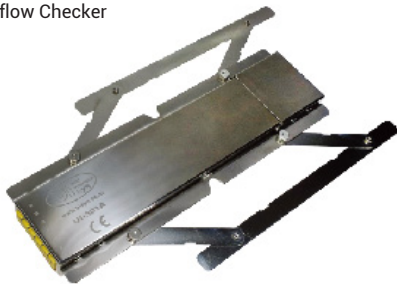

UI-301A16 [reflow checker]

Available in PbFree
Reflow Checker

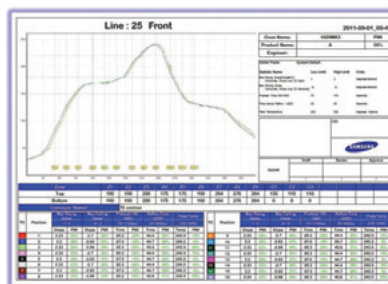

ETC SERVICE(MACHINE & EQUIPMENT)

SMT Reel Swap Error Protect System '2S-System'(오삽방지 시스템, MES/POP Solution)

2S-system improves quality in such a way - when working part change and first sample check, incase the worker input an item wrongly, 2S-system detects it and stops production to make him input items correctly.

Line Control Diagram

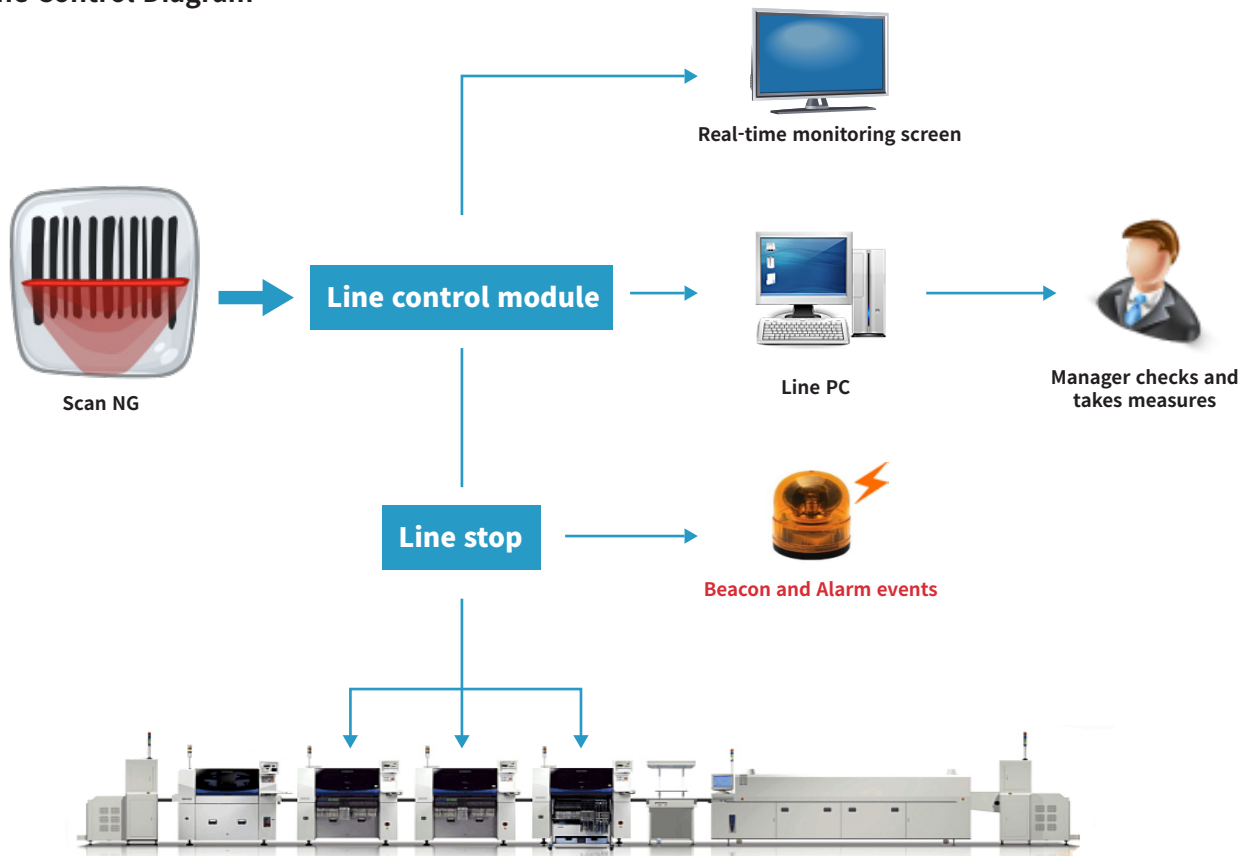

MES(Manufacturing Execution System) '2S-MES'

'2S-MES' is the solution which is available to give a feedback on problems from a field, after gathering and inspecting the field information from inputting materials to completing products by using automated machines in real time

Main Function	Explanation
Work order management	It supports making a production plan, confirming a work order and etc. through the production plan interface of the host system.
Performance list management of a production plan	It provides the information of performance list of a production plan to users according the work order of production process/machine.
LOT tracking management	It provides the total LOT quality information based on a production history from raw-material input to complete product.
Field management	It provides management function about the information of LOT, process inspection result, production performance through machine interface In real-time.
Inventory management	By using Bar Code / QR Code of materials or products, they are stored and released by first-in first-out. It provides convenience and stops an error of operators.
Interlock function	When process error occurs, it provides the function of production stop, process control.
Report & Monitoring	It is available to monitor in real time through gathering the production information, the relevant information for quality. And it provides a Report through an analysis.

ETC SERVICE(MACHINE & EQUIPMENT)

SMT PCB DIVIDER

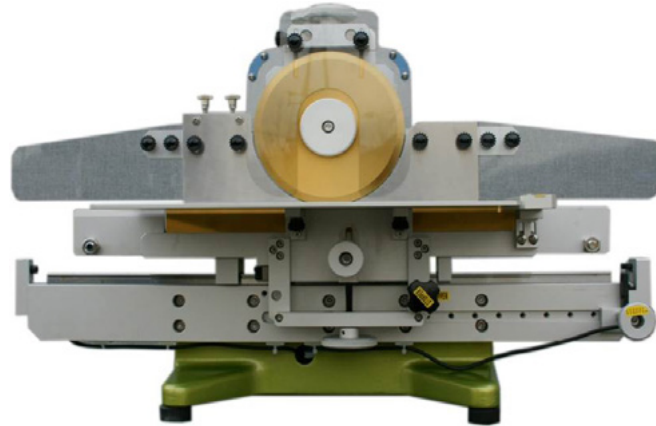

Specifications

	EM-260M	EM-360M	EM-460M	
Max Cut size	260mm	260mm	260mm	
Lower Blade / Straight type	270mm	370mm	470mm	upper blade
Ext Dimensions (mm)	600 x 645 x 432	600 x 816.5 x 439	600 x 1018 x 439	lower blade
Weight	37kg	39kg	42kg	
Upper Blade	Ø160 / Thickness 1.5mm / Circle type			
Component Limit	50mm upper side / 27mm lower side			
Manual <-> Motor	Can switch between manual operation and Motor operation for upper blade board sending			

AUTO-DISPENSER

BK-250 (for label)



BK-3300



BK-6000



BK-8000



ETC SERVICE(MACHINE & EQUIPMENT)

Jar-type Automatic solder paste dispenser

DW600SDS



- Automatic solder paste dispenser Single – 솔더 자동공급기 싱글
- Uses one 500g jar – 500g JAR 1통 사용
- Link with X-Moving equipment (optional) – X축 이송장치 연동(선택사양)
- Uses 500g jar solder paste for automaric solder paste dispenser – 솔더 자동공급기용 500g JAR 솔더페이스트 사용
- Separable operation panel (uses touch panel) – 운영패널 분리형 (Touch Panel 사용)

DW600SDM

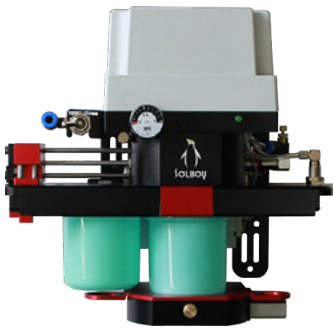

- Automatic solder paste dispenser Multi – 솔더 자동공급기 멀티
- Uses two 500g jars – 500g JAR 2통 사용
- Link with X-Moving equipment (optional) – X축 이송장치 연동(선택사양)
- Uses 500g jar solder paste for automaric solder paste dispenser – 솔더 자동공급기용 500g JAR 솔더페이스트 사용
- Separable operation panel (uses touch panel) – 운영패널 분리형 (Touch Panel 사용)

Key specifications of solder paste feeding unit

(자동 솔더페이스트 공급장치 주요사항)

Main item (주요항목)	DW600SDS	DW600SDM
Container of solder paste (솔더 페이스 용기)	500g JAR Type Container (500g JAR Type 용기)	
Solder Paste Supply Control (솔더페이스트 공급량 제어)	1~99g	
Supplying Cycle Control (공급주기 제어)	1~99 Printing Cycle (1~99 프린팅 주기)	
Pressure Type (가압 방식)	Air Pressure(5~6bar) – (공압5~6bar)	
Supply Voltage (공급 전압)	AC110V~265V 60Hz / DC 24V	
Dimensions(mm/HxWxL) (크기)	245x187x117	245x256x117
Weight (무게)	2.8kg	3.4kg
Amount of solder paste in case of one time (1회 솔더페이스트 양)	500g	1kg (500g Two Containers) (용기 2개)
MMI (Man Machine Interface)	TOUCH PANEL (터치판넬)	

Automatic Solder Paste Dispebser

(솔더페이스트 자동 공급기)

- Automatic Solder Paste Dispebser is a device to supply solder paste on the
- metal mask of the screen printer automatically by attaching it on the screen printer.
- 솔더페이스트 자동 공급기는 스크린프린터에 부착하여 메탈마스크 위에 일정량의
- 솔더페이스트를 자동으로 공급해주는 장치입니다.