

AMS

AUTOMATION, SMT & LEAN MANUFACTURING

MODULAR RACKING SYSTEM

ISO 9001/ ISO 14001 Certified

ADVANCED MECHATRONICS SOLUTIONS, INC

www.ams-fa.com

Manufactured by **G.S.ACE** KOREA

Contents

METAL RACKING SYSTEM

- PIPES (D-COATED / STS / ECCO)	5
- METAL JOINTS	11
- PLASTIC JOINTS	29

ALUMINUM RACKING SYSTEM

- ϕ 28 ALUMINUM RACKING SYSTEM	49
- ϕ 33 ALUMINUM RACKING SYSTEM	85
- ϕ 43 ALUMINUM RACKING SYSTEM	87
- 28X28 ALUMNUM RACKING SYSTEM	98
- 40X40 AL PROFILE RACKING SYSTEM	102
- 45X45 AL PROFILE RACKING SYSTEM	111

ROLLER TRACK SYSTEM

- ROLLER TRACKS (STANDARD / SILENT / STS COVERED / UNIVERSAL)	114
- ROLLER TRACK CAP	129
- ROLLER MOUNTING BRACKETS	132
- SLIDE PIPE MOUNTING BRACKETS	155
- BOX GUIDE	158
- BOX GUIDE CAP	165
- BOX STOPPER	166

CASTERS

- METAL CASTERS	171
- AL CASTERS	176
- FLOOR LOCK	178

ACCESSORIES

- PIPE REST & PLUG	180
- CASTER MOUNT & MOUNT CORNER UNIT	183
- FORK GUIDE & ASS'Y HAUL	191
- METAL CLAMP	196
- HOOK & HANGER & HANDLE	198
- METAL JOINT COVER	202
- TOOL HOLDER	204
- ASS'Y PULLEY	205
- NAME PLATE & LABEL CASE	208
- LEVELING FOOT	212
- THREADED INSERT & CAP	214
- PLASTIC CHANNEL	219
- FRAME GUIDE	220
- FASTENERS	222
- HAND CUTTER	224
- LIFT TABLE	225
- OTHERS	227

TECHNICAL SPECIFICATIONS	240
--------------------------	-----

EXAMPLES	261
----------	-----

INDEX	281
-------	-----

STEEL RACKING SYSTEM



- PIPE
 - D-COATED PIPE
 - STS PIPE
 - ECCO PIPE
- METAL JOINT
- PLASTIC JOINT

PIPES

COLOR: ● BK ○ WZ ● NI ○ PI

Unit : mm

COLOR CODE NUMBERING SYSTEM FOR PIPE

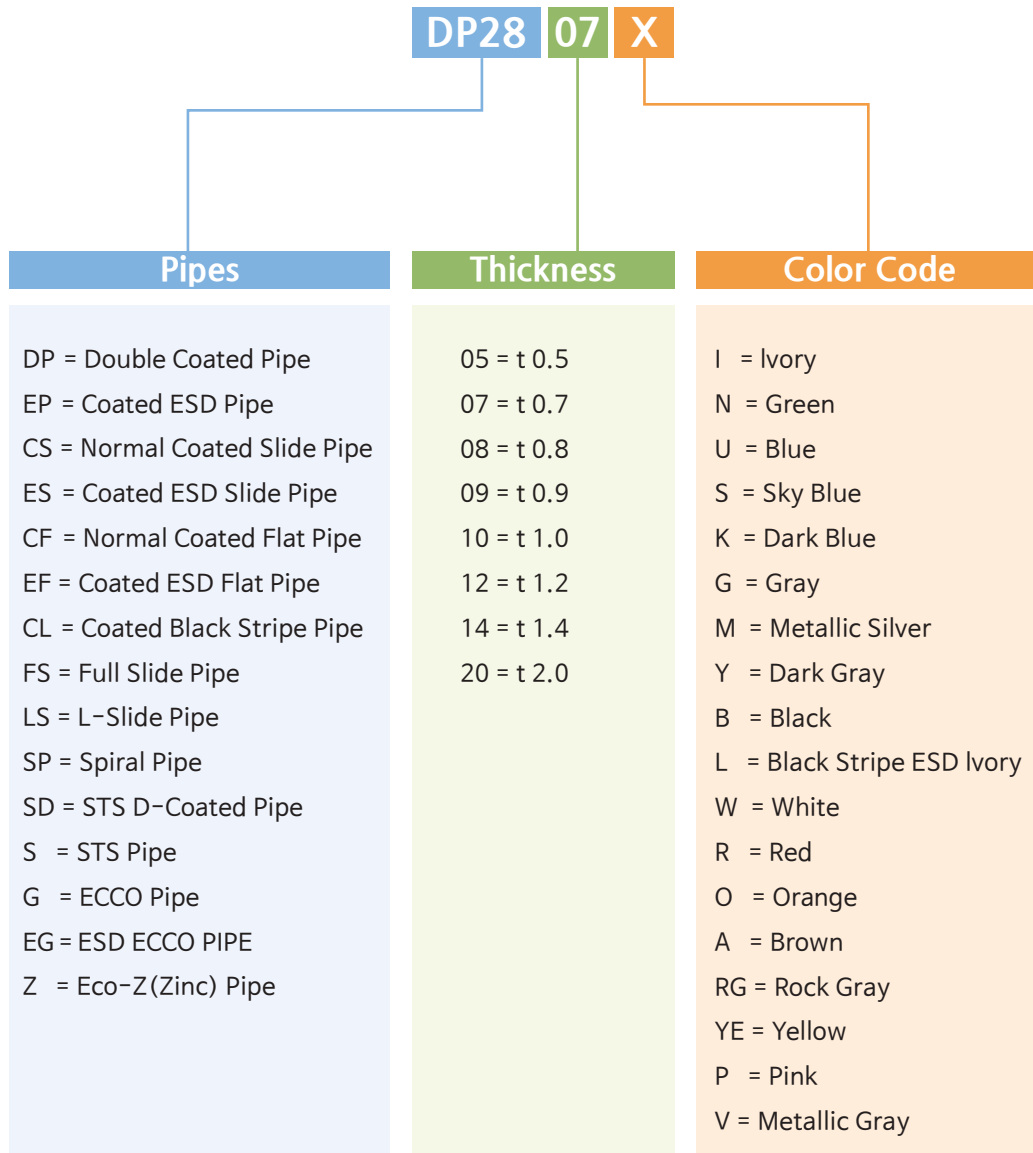

Example : Case of coated Pipe Ivory $\varnothing 28 \times t 1.0$ is DP2810-i

PIPES

NUMBERING SYSTEM

Unit : mm

Classification	Item	Part No		Thickness	Weight (g)/M	Type	
		Normal Pipe	ESD Pipe				
Coated Pipe	D-Coated Pipe	DP2807-X	EP2807-X	∅28×t0.7	505		
		DP2809-X	EP2809-X	∅28×t0.9	630		
		DP2810-X	EP2810-X	∅28×t1.0	700		
		DP2814-X	EP2814-X	∅28×t1.4	830		
		DP2820-X	EP2820-X	∅28×t2.0	1,130		
		DP3210-X	-	∅32×t1.0	810		
	STS-D-Coated Pipe	SD2805-X	-	∅28×t0.5	395		
	Slide Pipe	CS2807-X	ES2807-X	∅28×t0.7	582		
		CS2809-X	ES2809-X	∅28×t0.9	650		
		CS2810-X	ES2810-X	∅28×t1.0	767		
		CS2820-X	ES2820-X	∅28×t2.0	690		
	Full Slide Pipe	FS2807-X	FS2807-E	∅28×t0.7	505		
		FS2809-X	FS2809-E	∅28×t0.9	630		
	L-Slide Pipe	LS2809-X	LS2809-E	∅28×t0.9	690		
		LS2810-X	LS2810-E	∅28×t1.0	750		
	Flat Pipe	CF2807-X	EF2807-X	∅28×t0.7	606		
		CF2809-X	EF2809-X	∅28×t0.9	720		
		CF2810-X	EF2810-X	∅28×t1.0	790		
	Black Stripe Pipe	-	CL2807-X	∅28×t0.7	505		
		-	CL2810-X	∅28×t1.0	690		
W-Pipe		RC2809 (Roller Conveyor)		∅28×t0.9	570		
Spiral Pipe		SP2809		∅28×t0.9	630		
ECCO-Pipe	Powder Pipe	G2807-X	EG2807-X	∅28×t0.7	475		
		G2809-X	EG2809-X	∅28×t1.0	600		
		G2812-X	EG2812-X	∅28×t1.2	800		
		G2820-X	EG2820-X	∅28×t2.0	1100		
		Z2808			∅28×t0.8		
STS Pipe	Polished Pipe	S2807A		∅28×t0.7	448		
		S2809A		∅28×t0.9	581		
		S2812A		∅28×t1.2	760		

※ Standard Length - 4,000

PIPES

COLOR TABLE











Unit : mm

Classification			Standard Length : 4000								
			ECCO Pipe				Coated Pipe				
			Standard	Color	Ø28 xT0.7	Ø28 xT0.9	Ø28 xT1.2	Ø28 xT2.0	Ø28 xT0.7	Ø28 xT0.9	Ø28 xT1.0
Normal Pipe	Ivory		●	●	●	●	●	●	●	●	●
	Green		●	●	●	●	●	●	●	●	●
	Blue		-	-	-	-	●	●	●	●	●
	Sky Blue		-	-	-	-	●	●	●	●	●
	Dark Blue		●	●	●	●	●	●	●	●	●
	Gray		-	-	-	-	●	●	●	●	●
	Rock Gray		-	-	-	-	●	●	●	●	●
	Dark Gray		-	-	-	-	●	●	●	●	●
	Black		-	-	-	-	●	●	●	●	●
	White		●	●	●	●	●	●	●	●	●

PIPES

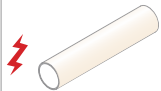
Unit : mm

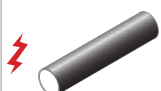
MRS

Classification			Standard Length : 4000									
			Standard		ECCO Pipe				Coated Pipe			
					Ø28 xT0.7	Ø28 xT0.9	Ø28 xT1.2	Ø28 xT2.0	Ø28 xT0.7	Ø28 xT0.9	Ø28 xT1.0	Ø28 xT1.4
Color												
Normal Pipe	Red		-	-	-	-	●	●	●	●	●	
	Orange		-	-	-	-	●	●	●	●	●	
	Brown		-	-	-	-	●	●	●	●	●	
	Yellow		●	●	●	●	●	●	●	●	●	
	Pink		-	-	-	-	●	●	●	●	●	
	Spiral		-	-	-	-	-	-	●	-	-	
ESD Pipe Antistatic: $10^7 \Omega$ $\sim 10^{10} \Omega$	Ivory		-	-	-	-	-	-	●	-	-	
	Gray		●	●	●	●	●	●	●	●	●	
ESD Pipe Conductivity: $10^3 \Omega$ $\sim 10^6 \Omega$	Black		●	●	●	●	●	●	●	●	●	
	Black Stripe		-	-	-	-	●	-	-	-	●	

FEATURES OF D-COAT PIPE



1. Steel Pipe is coated with ABS and final coated with newly developed material by G.S.ACE.
2. Compared to the conventional ABS coating pipe, D-Coat Pipe is outstanding in oil resistance and chemical resistance. In particular, salinity, rust preventative oil or cutting oil does not cause cracks or discoloration of the pipe.
3. This product comes in a variety of colors for use in various items or per company's image.
4. With outstanding durability, this pipe is easily processed. Rustproof coating inside the pipe provides superior corrosion resistance.

※ D-Coat Pipe is printed with 'D-COAT G.S.ACE'.

CHEMICAL RESISTANCE OF COATING PIPE

Chemical	Test Method	Result		Chemical	Test Method	Result	
		D-COAT	ABS COAT			D-COAT	ABS COAT
Rust Preventative Oil	Coating	○	△	Transmission Oil	Coating	○	×
Sodium Chloride (Sweat)	Coating	○	×	Hair Spray	Coating	○	○
Brake Oil	Coating	○	×	Permanent Solution	Coating	○	○
UV Ray	Radiation	○	△	Pesticide	Coating	○	○
Cutting Oil	Coating	○	×	Sterilizer	Coating	○	○
Dishwashing Detergent	Coating	○	△	Liquid Fertilizer	Coating	○	○
Laundry Detergent	Coating	○	○	Soybean Oil	Coating	○	×
Bathroom Detergent	Coating	○	○	Bleach	Coating	○	○
Methyl Ethyl Keton	Deposition	×	×	Ethanol	Deposition	○	○
Ethylene Glycol	Deposition	○	○	Toluene	Deposition	×	×

1. Test Condition - Test by depositing pipe in or coating it with the designated chemical for 30 days
2. Notes - ○ : No change
 △ : Change was observed, but the pipe is still usable.
 × : Resin melted or crack occurred.

ECCO PIPE - Environment Conservation Improvement of Cost

CO : Cost Down
 E : Environment
 C : Conservation

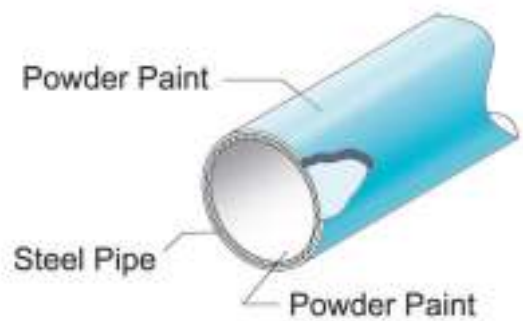
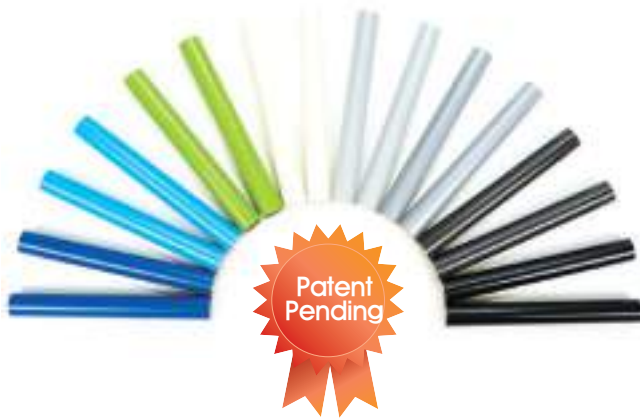

1. Environmental

- ECO-pipe is fully recyclable.
- Powder painted steel pipe of internal and external surface

2. Economical

- 20% less than coated pipe
- 35% less than ESD coated pipe
- 30% less than stainless steel pipe

3. Colorful

- Wider selection of colors and textures.

4. Chemical resistant

- High resistant to oil, UV light, and corrosion.

5. Non-flammable

- No emission of toxic fumes in fire.

6. Electrolytic Corrosion Free

- Free of Electrolytic Corrosion.

THE ADVANTAGES OF STAINLESS PIPE

1. Environmental

- Stainless pipe which is 100% recycable

2. High Strength & Durability

- Surface resistant to light abrasion or contact with metal tools

3. High Oil & Chemical Resistance

- High resistance to oil, solvents, bleaches, etc.

4. Non-Flammable

- Inherently non-flammable.

5. Conductive

- Inherently conductive

STS PIPE VS. COATED PIPE BENDING STRENGTH

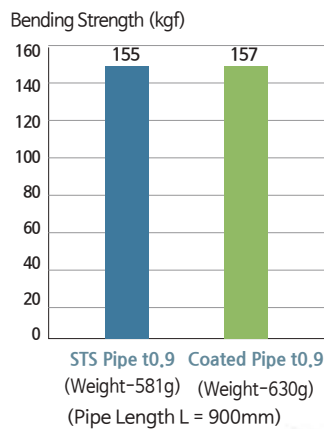

Stainless Pipe



METAL JOINTS FOR Ø28 (S-SERIES)

COLOR: ● BK ○ WZ ● NI ○ PI

Unit : mm

MRS

G-1S

- Weight : 0.068kg
- Q'ty/Box : 240pcs

G-1BS

- Weight : 0.061kg
- Q'ty/Box : 240pcs

G-2S

- Weight : 0.095kg
- Q'ty/Box : 150pcs

G-3S

- Weight : 0.120kg
- Q'ty/Box : 70pcs

G-4S

- Weight : 0.105kg
- Q'ty/Box : 180pcs

G-6S

- Weight : 0.048kg
- Q'ty/Box : 180pcs

G-6BS

- Weight : 0.042kg
- Q'ty/Box : 240pcs

G-6B-33

- Weight : 0.046kg
- Q'ty/Box : 180pcs

G-7AS

- Weight : 0.044kg
- Q'ty/Box : 300pcs

G-7BS

- Weight : 0.052kg
- Q'ty/Box : 300pcs

METAL JOINTS FOR Ø28 (S-SERIES)

COLOR: ● BK ○ WZ ● NI ○ PI

Unit : mm

G-7CS

Patented

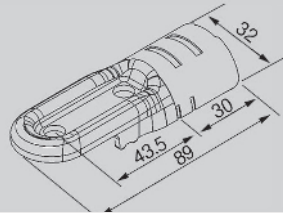

- Weight : 0.062kg
- Q'ty/Box : 210pcs

G-8S

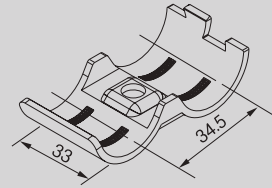

- Weight : 0.049kg
- Q'ty/Box : 300pcs

G-9S

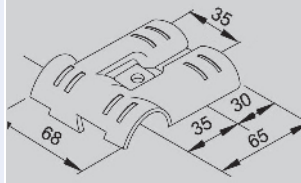

- Weight : 0.120kg
- Q'ty/Box : 100pcs

G-12S

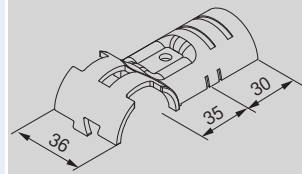

- Weight : 0.060kg
- Q'ty/Box : 210pcs

G-13AS

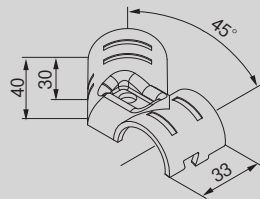

- Weight : 0.063kg
- Q'ty/Box : 160pcs

G-13BS

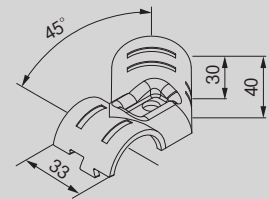

- Weight : 0.062kg
- Q'ty/Box : 160pcs

G-14S

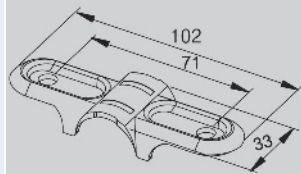

- Weight : 0.052kg
- Q'ty/Box : 270pcs

G-15AS

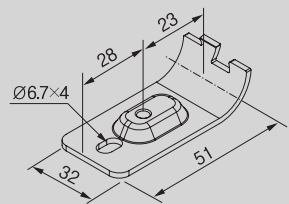

- Weight : 0.040kg
- Q'ty/Box : 480pcs

G-15BS

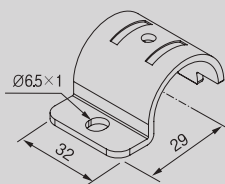

- Weight : 0.037kg
- Q'ty/Box : 480pcs

G-15AH

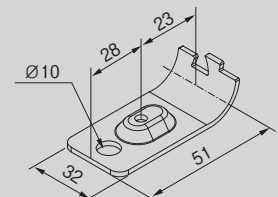

- Weight : 0.046kg
- Q'ty/Box : 480pcs

METAL JOINTS FOR Ø28 (S-SERIES)

COLOR: ● BK ○ WZ ● NI ○ PI

Unit : mm

<p>G-15BL</p> 	 <ul style="list-style-type: none"> • Weight : 0.056kg • Q'ty/Box : 240pcs 	<p>G-15D</p> 	 <ul style="list-style-type: none"> • Weight : 0.048kg • Q'ty/Box : 300pcs
<p>G-15DL</p> 	 <ul style="list-style-type: none"> • Weight : 0.047kg • Q'ty/Box : 300pcs 	<p>G-15G</p> 	 <ul style="list-style-type: none"> • Weight : 0.048kg • Q'ty/Box : 300pcs
<p>G-16S</p> 	 <ul style="list-style-type: none"> • Weight : 0.049kg • Q'ty/Box : 300pcs 	<p>G-17S</p> 	 <ul style="list-style-type: none"> • Weight : 0.057kg • Q'ty/Box : 200pcs
<p>G-18S</p> 	 <ul style="list-style-type: none"> • Weight : 0.057kg • Q'ty/Box : 180pcs 	<p>G-20S</p> 	 <ul style="list-style-type: none"> • Weight : 0.064kg • Q'ty/Box : 200pcs
<p>G-22S</p> 	 <ul style="list-style-type: none"> • Weight : 0.085kg • Q'ty/Box : 150pcs 	<p>G-23S</p> 	 <ul style="list-style-type: none"> • Weight : 0.099kg • Q'ty/Box : 130pcs

MRS

METAL JOINTS FOR Ø28 (S-SERIES)

COLOR: ● BK ○ WZ ● NI ○ PI

Unit : mm

G-24S

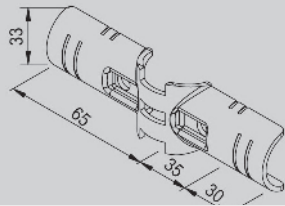

- Weight : 0.092kg
- Q'ty/Box : 150pcs

G-25AS

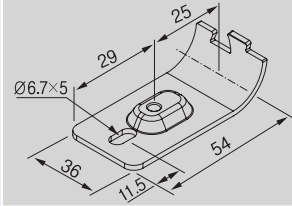

- Weight : 0.050kg
- Q'ty/Box : 360pcs

G-25BS

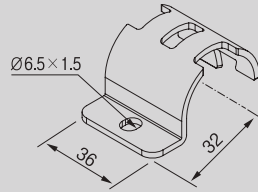

- Weight : 0.043kg
- Q'ty/Box : 360pcs

G-25C

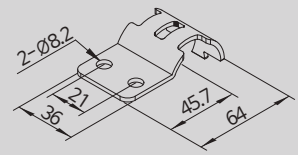

- Weight : 0.042kg
- Q'ty/Box : 300pcs

G-28

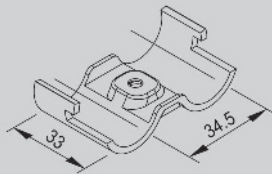

- Weight : 0.050kg
- Q'ty/Box : 240pcs

G-30S

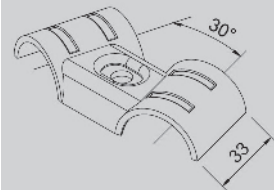

- Weight : 0.060kg
- Q'ty/Box : 240pcs

G-34S

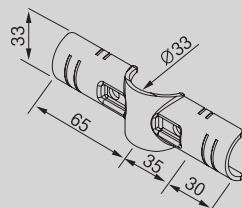

- Weight : 0.105kg
- Q'ty/Box : 180pcs

G-35AS

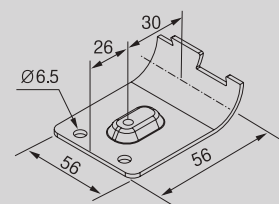

- Weight : 0.080kg
- Q'ty/Box : 240pcs

G-35BS

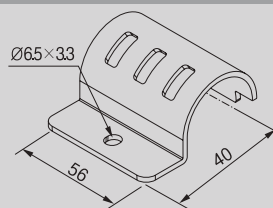

- Weight : 0.075kg
- Q'ty/Box : 240pcs

G-38S

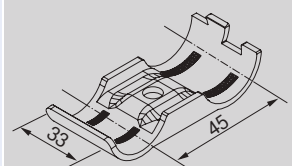

- Weight : 0.057kg
- Q'ty/Box : 300pcs

METAL JOINTS FOR $\varnothing 28$ (S-SERIES)

COLOR: ● BK ○ WZ ● NI ○ PI

Unit : mm

<p>G-44</p> <p>Design Patent</p> 	 <ul style="list-style-type: none"> • Weight : 0.070kg • Q'ty/Box : 270pcs 	<p>G-45S</p> 	 <ul style="list-style-type: none"> • Weight : 0.071kg • Q'ty/Box : 200pcs
<p>G-54S</p> 	 <ul style="list-style-type: none"> • Weight : 0.099kg • Q'ty/Box : 120pcs 	<p>G-60S</p> 	 <ul style="list-style-type: none"> • Weight : 0.076kg • Q'ty/Box : 200pcs
<p>G-65S For $\varnothing 5$</p> 	 <ul style="list-style-type: none"> • Weight : 0.038kg • Q'ty/Box : 480pcs 	<p>G-65S-10 For $\varnothing 10$</p> 	 <ul style="list-style-type: none"> • Weight : 0.0380kg • Q'ty/Box : 480pcs
<p>G-66 Material : Aluminum</p> 	 <ul style="list-style-type: none"> • Weight : 0.042kg • Q'ty/Box : 120pcs 	<p>G-75A</p> 	 <ul style="list-style-type: none"> • Weight : 0.016kg • Q'ty/Box : 400pcs
<p>G-75B</p> 	 <ul style="list-style-type: none"> • Weight : 0.016kg • Q'ty/Box : 400pcs 	<p>G-90S</p> <p>Patented</p> 	 <ul style="list-style-type: none"> • Weight : 0.096kg • Q'ty/Box : 100pcs

METAL JOINTS FOR Ø28 (S-SERIES)

COLOR: ● BK ○ WZ ● NI ○ PI

Unit : mm

G-101

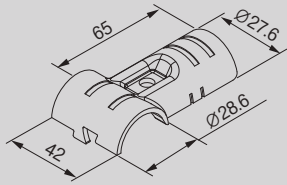

- Weight : 0.074kg
- Q'ty/Box : 180pcs

* For $\phi 28.6$

G-102

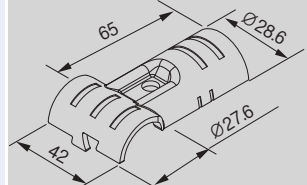

- Weight : 0.074kg
- Q'ty/Box : 200pcs

* For $\phi 28.6$

G-103

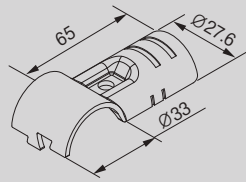

- Weight : 0.07kg
- Q'ty/Box : 240pcs

* Joint for assembling on the Joint

G-104

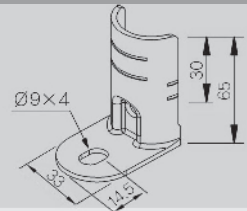

- Weight : 0.070kg
- Q'ty/Box : 240pcs

G-105

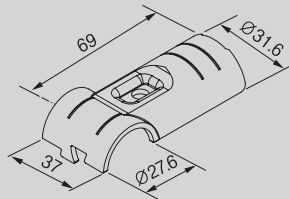

- Weight : 0.080kg
- Q'ty/Box : 200pcs

G-106

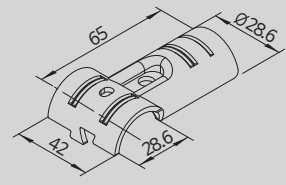

- Weight : 0.078kg
- Q'ty/Box : 200pcs

G-301

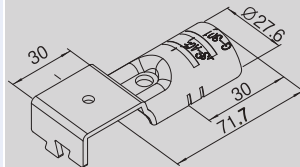

- Weight : 0.077kg
- Q'ty/Box : 180pcs

G-110S

Design Patent

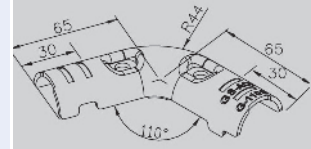

- Weight : 0.103kg
- Q'ty/Box : 100pcs

G-135S

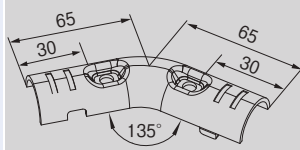

- Weight : 0.102kg
- Q'ty/Box : 100pcs

G-160S

Design Patent

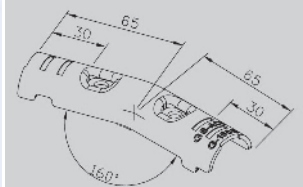

- Weight : 0.105kg
- Q'ty/Box : 100pcs

METAL JOINTS FOR Ø28 (S-SERIES)

COLOR: ● BK ○ WZ ● NI ○ PI

Unit : mm

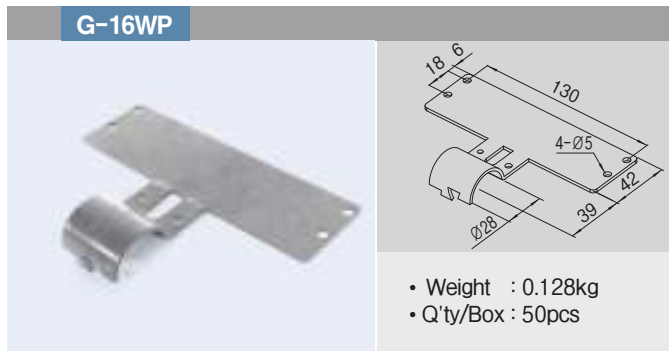

The Most Innovated Joints In the Industry.

S-Series Joint

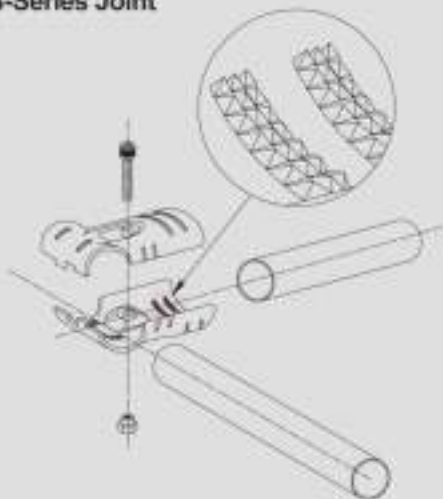

METAL JOINTS – SERIES FEATURES

- Newly developed and patented design for Ø28 stainless steel pipes.
- Excellent grip characteristics achieved by introducing series of protruded pyramids in contact with stainless steel pipes.
- When used with coated pipes, grip is enhanced by 30%

SURFACE TREATMENT & CODE NUMBER

Code	Surface Treatment	Remarks
BK	Black Coating	Non Chrome
WZ	Zinc Plating (White)	Cro3
Ni	Nickel Plating	Non Chrome
PI	Powder Coating (Ivory)	

METAL JOINT ASSEMBLY FOR Ø28 (S-SERIES)

COLOR: ●BK ○WZ ●NI ○PI

Unit : mm

MRS

GA-1S



Material	Metal
G-1S	2pcs
M0625/TN06	1set

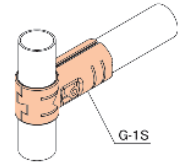
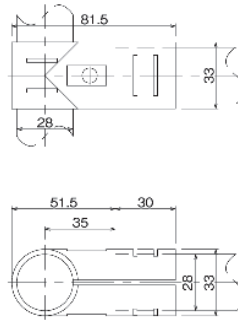

GA-1BS



Material	Metal
G-1BS	2pcs
M0625/TN06	1set

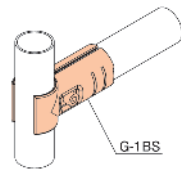
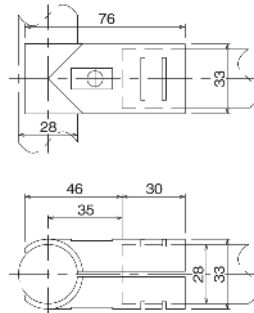

GA-2S



Material	Metal
G-2S	1pcs
G-3S	1pcs
M0625/TN06	2set

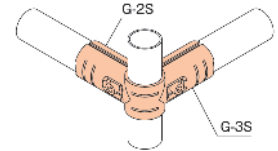
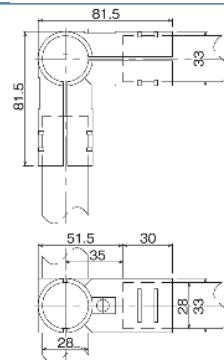

GA-3S



Material	Metal
G-2S	2pcs
G-4S	1pcs
M0625/TN06	3set

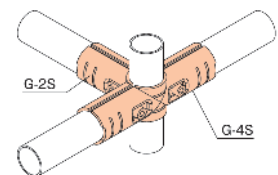
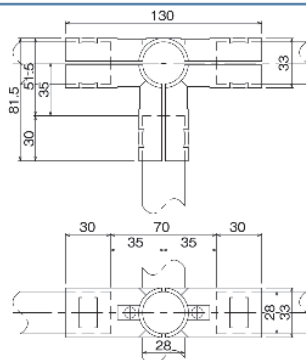

GA-4S



Material	Metal
G-4S	2pcs
M0625/TN06	2set

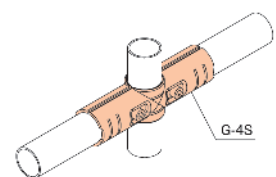
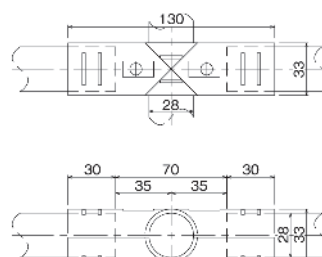

METAL JOINT ASSEMBLY FOR Ø28 (S-SERIES)

COLOR: ● BK ○ WZ ● NI ○ PI

Unit : mm

MRS



GA-5S

Material	Metal
G-2S	4pcs
M0625/TN06	4set

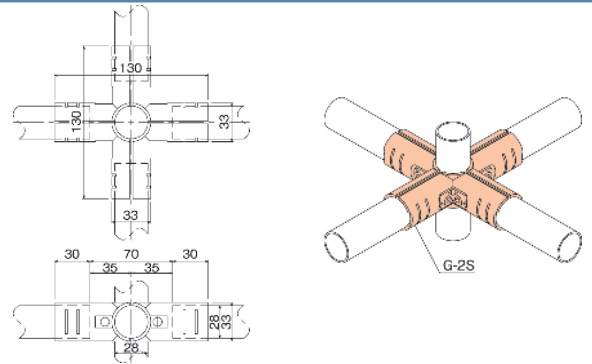

GA-6S

Material	Metal
G-6S	2pcs
M0625/TN06	1set

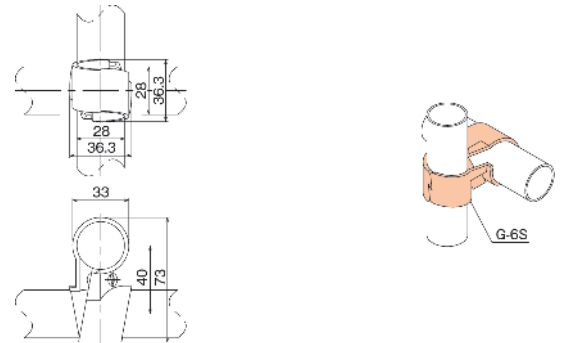

GA-6BS

Material	Metal
G-6BS	2pcs
M0625/TN06	1set

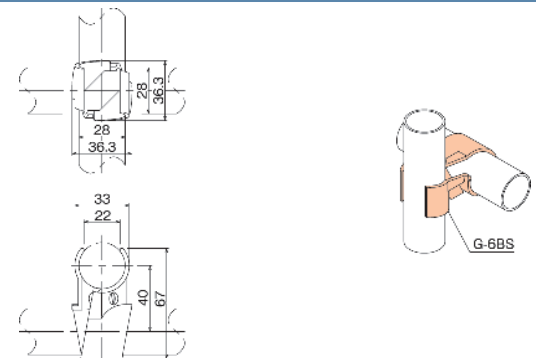

GA-6B-33

Material	Metal
G-6B-33	2pcs
M0625/TN06	1set

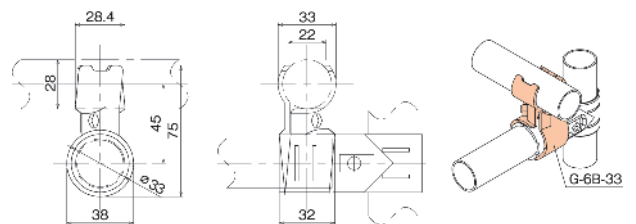

GA-7S

Material	Metal
G-7AS	2pcs
G-7BS	2pcs
M0625/TN06	2set

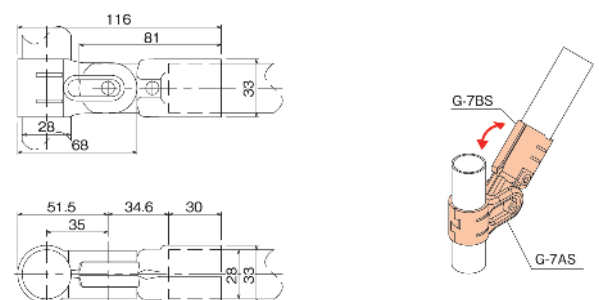

METAL JOINT ASSEMBLY FOR Ø28 (S-SERIES)

COLOR: ● BK ○ WZ ● NI ○ PI

Unit : mm

MRS

GA-8S



Material	Metal
G-8S	2pcs
M0625/TN06	1set

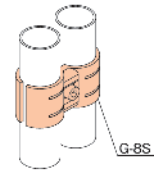
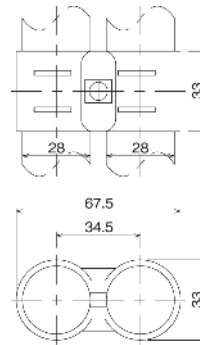

GA-9S



Material	Metal
G-9S	2pcs
M0625/TN06	1set

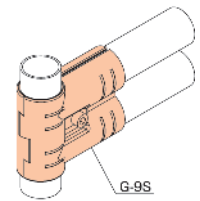
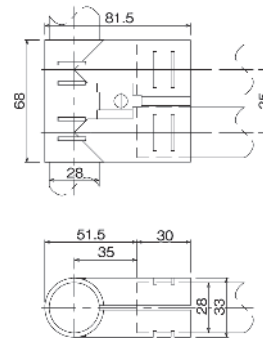

GA-12S



Material	Metal
G-12S	2pcs
GAP-12	1pcs
M0625/TN06	1set

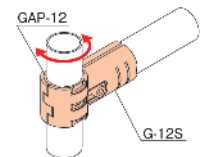
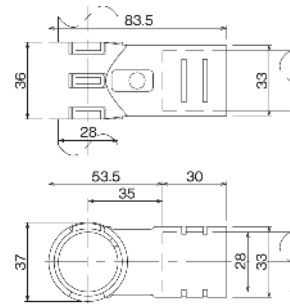

GA-13S



Material	Metal
G-13AS	1pcs
G-13BS	1pcs
M0625/TN06	1set

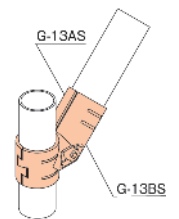
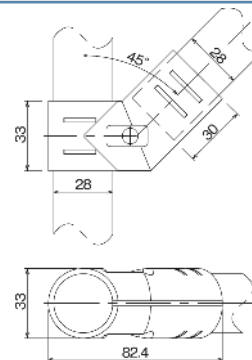

GA-14S



Material	Metal
G-14S	2pcs
G-7BS	4pcs
M0625/TN06	4set

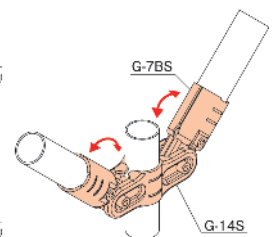
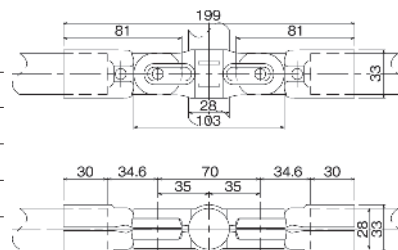

METAL JOINT ASSEMBLY FOR Ø28 (S-SERIES)

COLOR: ● BK ○ WZ ● NI ○ PI

Unit : mm

MRS

GA-15S



Material	Metal
G-15AS	1pcs
G-15BS	1pcs
M0610	1pcs

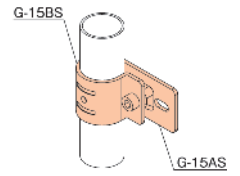
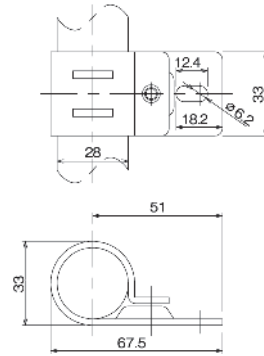

GA-15D



Material	Metal
G-15D	1pcs
G-15BS	1pcs
M0610	1pcs

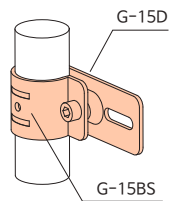
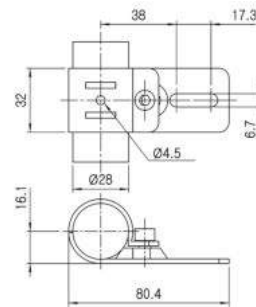

GA-15H



Material	Metal
G-15AH	1pcs
G-15BS	1pcs
M0610	1pcs

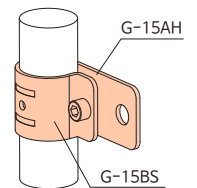
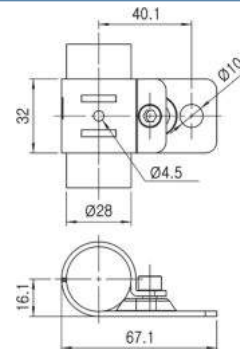

GA-15L



Material	Metal
G-15BL	1pcs
G-15DL	1pcs
M0615	1pcs
N06W-55	1pcs
PW06	1pcs

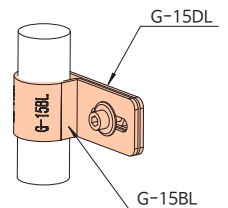
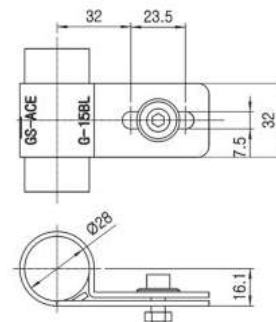

GA-15G



Material	Metal
G-15G	1pcs
G-15BS	1pcs
M0610	1pcs

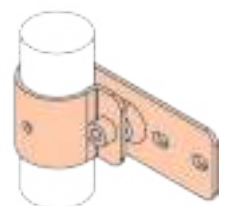
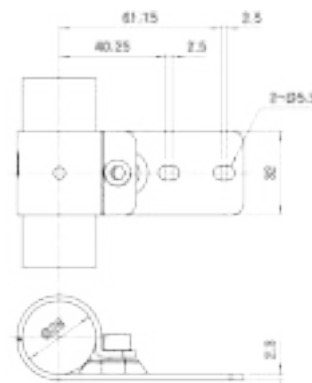

METAL JOINT ASSEMBLY FOR Ø28 (S-SERIES)

COLOR: ● BK ○ WZ ● NI ○ PI

Unit : mm

MRS

GA-16S



Material	Metal
G-16S	2pcs
PW8x25	2pcs

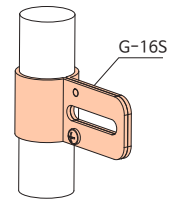
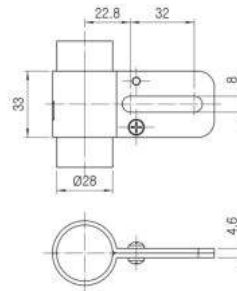

GA-17S



Material	Metal
G-17S	2pcs
GAP-12	1pcs
M0625/TN06	1set

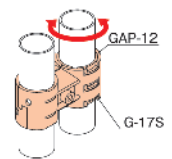
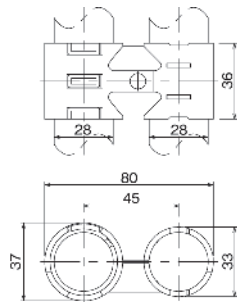

GA-18S



Material	Metal
G-18S	2pcs
GAP-12	2pcs
M0625/TN06	1set

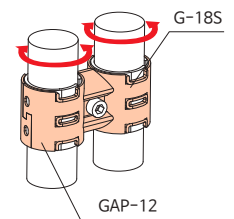
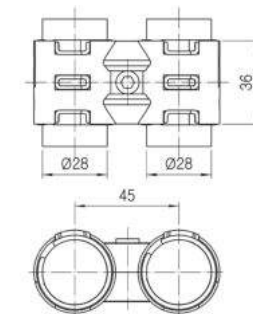

GA-20S



Material	Metal
G-20S	1pcs
G-1S	1pcs
M0625/TN06	1set

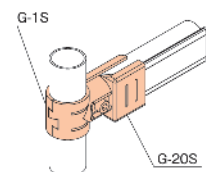
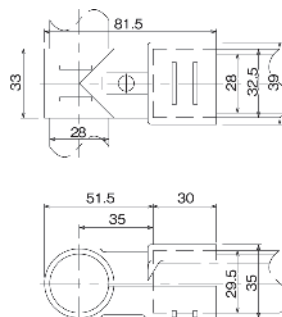

GA-23S



Material	Metal
G-23S	2pcs
M0625/TN06	2set

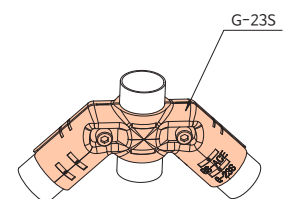
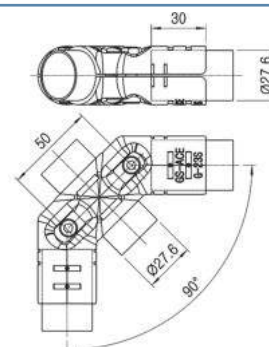

METAL JOINT ASSEMBLY FOR Ø28 (S-SERIES)

COLOR: ● BK ○ WZ ● NI ○ PI

Unit : mm

MRS

GA-24S



Material	Metal
G-24S	2pcs
GAP-12	1pcs
M0625/TN06	2 set

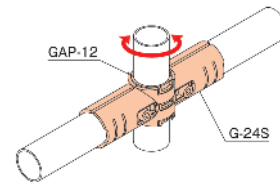
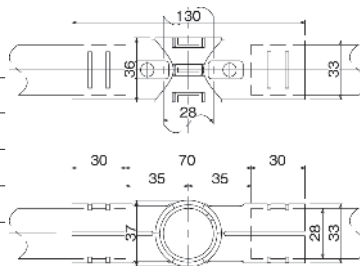

GA-25S



Material	Metal
G-25AS	1pcs
G-25BS	1pcs
GAP-12	1pcs
M0610	1pcs

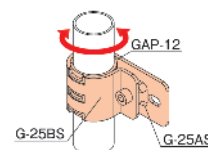
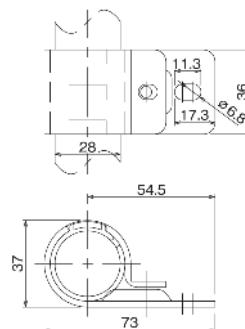

GA-25C



Material	Metal
G-25C	2pcs
GAP-12	1pcs
M0825/TN08	2set

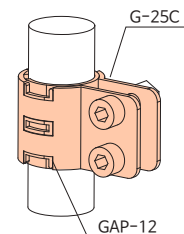
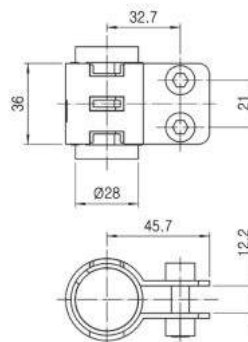

GA-27S

Patented



Material	Metal
G-7CS	2pcs
G-7BS	2pcs
M0625/TN06	3set

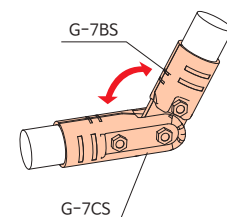
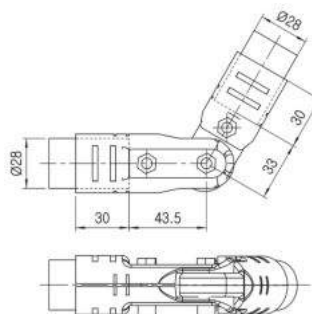

GA-28



Material	Metal
G-28	2pcs
M0625/TN06	1set

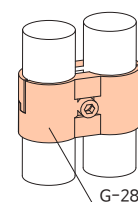
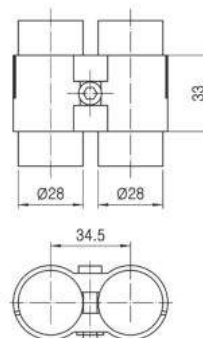

METAL JOINT ASSEMBLY FOR Ø28 (S-SERIES)

COLOR: ● BK ○ WZ ● NI ○ PI

Unit : mm

MRS

GA-30S



Material	Metal
G-30S	2pcs
M0625/TN06	1set

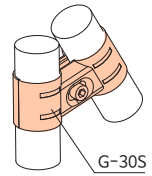
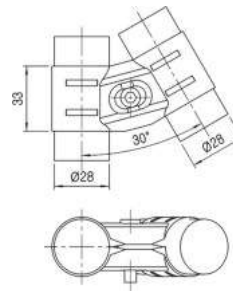

GA-34S



Material	Metal
G-34S	2pcs
M0625/TN06	2set

* Joint for assembling on the Joint

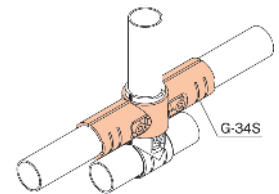
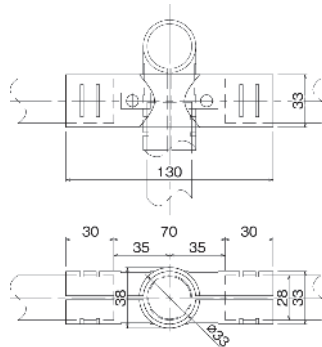

GA-35S



Material	Metal
G-35AS	1pcs
G-35BS	1pcs
GAP-56	1pcs
M0610	1pcs

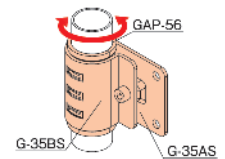
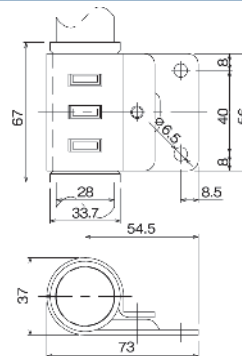

GA-38S



Material	Metal
G-38S	2pcs
M0625/TN06	1set

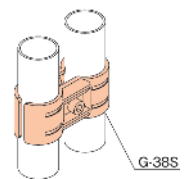
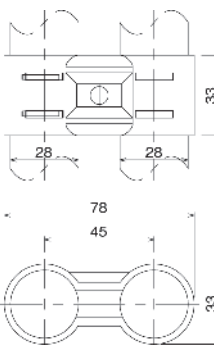

GA-44

Design Patent



Material	Metal
G-44	2pcs
M0625/TN06	1set

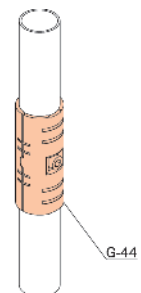
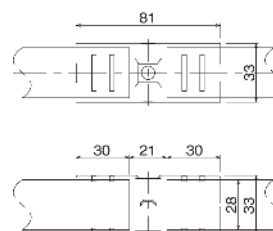

METAL JOINT ASSEMBLY FOR Ø28 (S-SERIES)

COLOR: ● BK ○ WZ ● NI ○ PI

Unit : mm

MRS

GA-45S



Material	Metal
G-45S	2pcs
M0625/TN06	1set

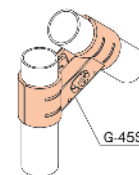
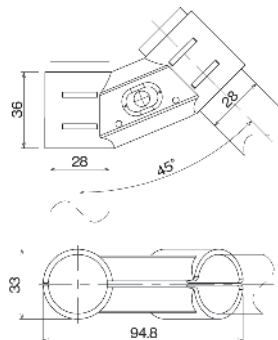

GA-54S



Material	Metal
G-54S	1pcs
G-4S	1pcs
M0625/TN06	2set

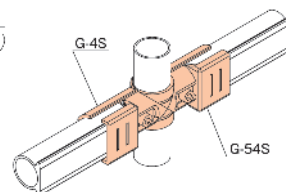
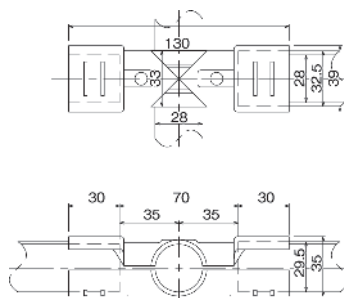

GA-55S



Material	Metal
G-22S	4pcs
GAP-12	1pcs
M0625/TN06	4set

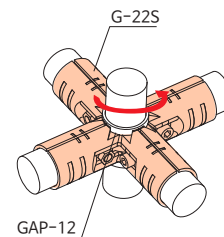
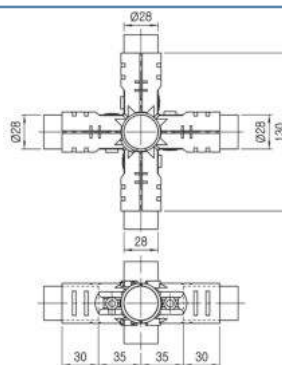

GA-60S



Material	Metal
G-60S	2pcs
M0625/TN06	1set

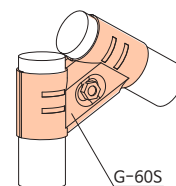
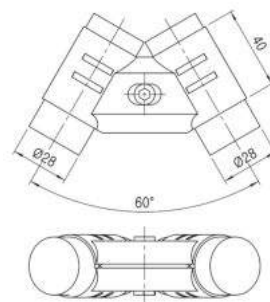

GA-65S For Ø5



Material	Metal
G-65S	2pcs
M0610/TN06	1set

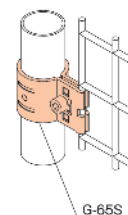
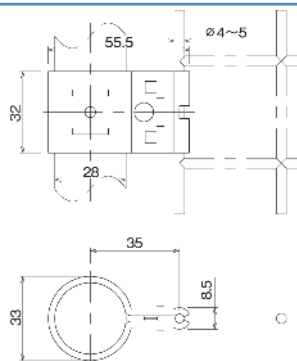

METAL JOINT ASSEMBLY FOR Ø28 (S-SERIES)

COLOR: ● BK ○ WZ ● NI ○ PI

Unit : mm

MRS

GA-65S-10 For Ø10



Material	Metal
G-65S-10	2pcs
M0615/TN06	1set

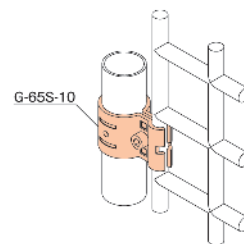
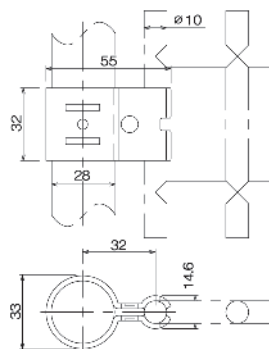

GA-66 Material : Aluminum



Material	Aluminum
G-66	2pcs
M0625/TN06	1set

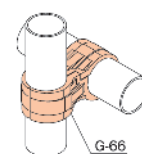
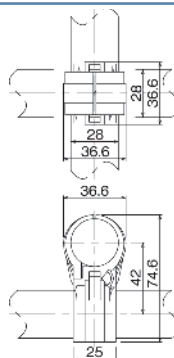

GA-75 Joint Stopper



Material	Metal
G-75A	1pcs
G-75B	1pcs
M0610	1pcs

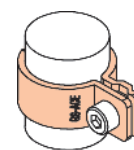
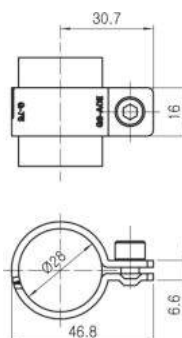

GA-90S

Patented



Material	Metal
G-90S	2pcs
M0625/TN06	1set

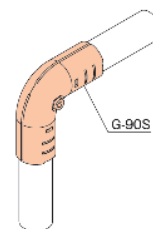
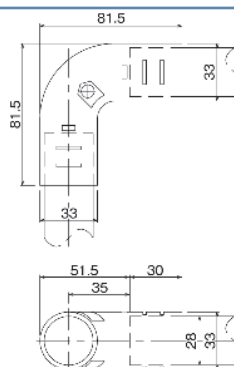

GA-101



Material	Metal
G-101	2pcs
M0625/TN06	1set

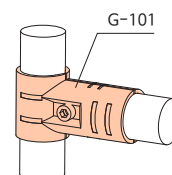
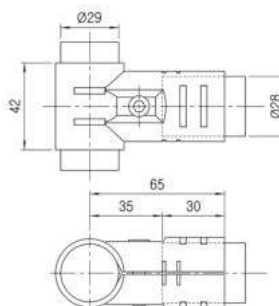

METAL JOINT ASSEMBLY FOR Ø28 (S-SERIES)

COLOR: ● BK ○ WZ ● NI ○ PI

Unit : mm

MRS

GA-102



Material	Metal
G-102	2pcs
M0625/TN06	1set

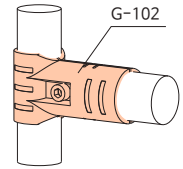
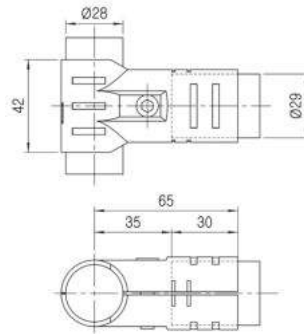

GA-103



Material	Metal
G-103	2pcs
M0625/TN06	1set

* Joint for assembling on the Joint

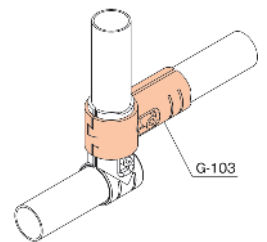
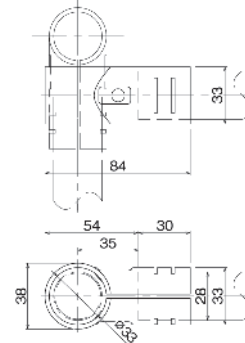

GA-104



Material	Metal
G-104	2pcs
M0625/TN06	1set

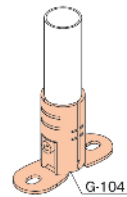
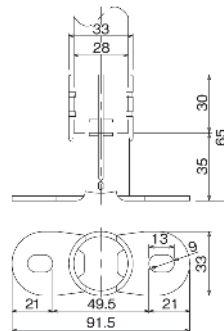

GA-105



Material	Metal
G-105	2pcs
M0625/TN06	1set

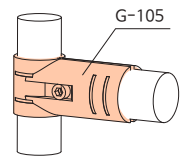
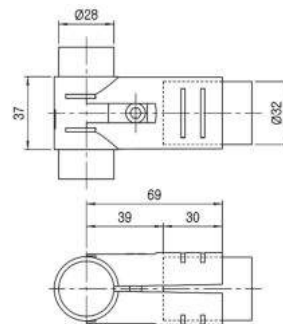

GA-106



Material	Metal
G-106	2pcs
M0625/TN06	1set

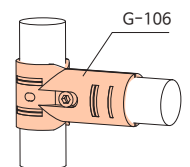
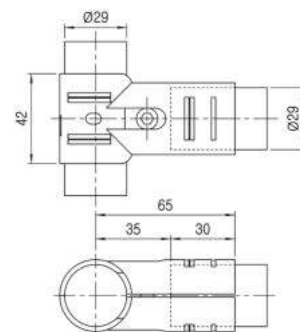

METAL JOINT ASSEMBLY FOR Ø28 (S-SERIES)

COLOR: ● BK ○ WZ ● NI ○ PI

Unit : mm

MRS

GA-110S

Design Patent



Material	Metal
G-110S	2pcs
M0625/TN06	2set

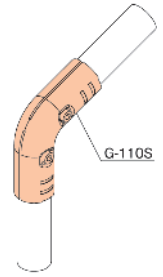
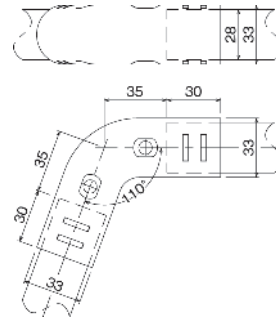

GA-135S



Material	Metal
G-135S	2pcs
M0625/TN06	2set

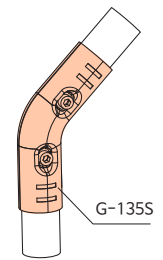
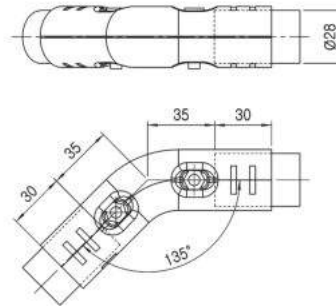

GA-160S

Design Patent



Material	Metal
G-160S	2pcs
M0625/TN06	2 set

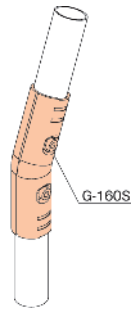
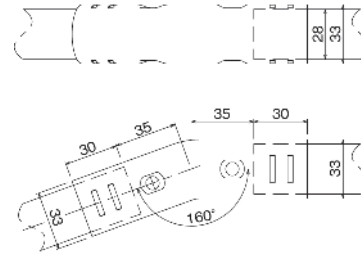

GA-301



Material	Steel
G-301	2pcs
M0625/TN06	1 set

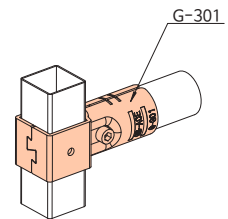
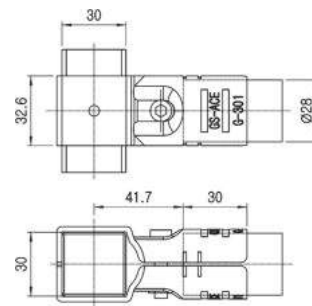

PLASTIC JOINTS

COLOR : Ivory  Gray  Green  Esd 

Unit : mm

MRS

GAP-1 Plastic Joint



Material	ASA
Weight	0.030kg
Q'ty/Box	150pcs

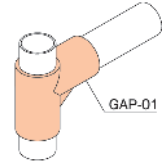
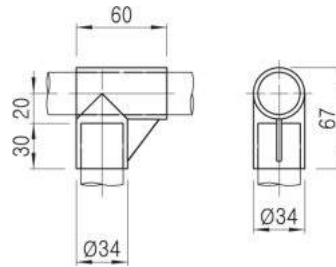

GAP-2A Plastic Joint



Material	ASA
Weight	0.045kg
Q'ty/Box	75pcs

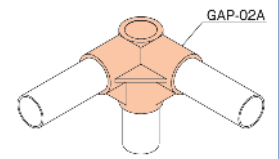
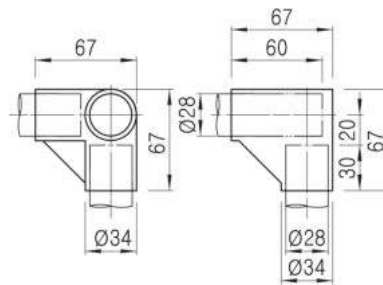

GAP-2B Plastic Joint (Penetrated Model)



Material	ASA
Weight	0.048kg
Q'ty/Box	75pcs

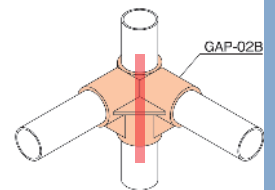
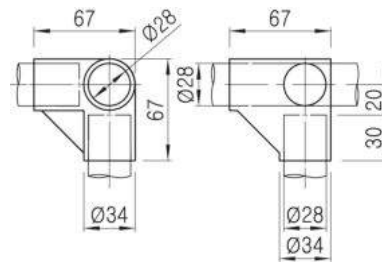

GAP-3 Outer Cap



Material	ASA
Weight	0.009kg
Q'ty/Box	900pcs

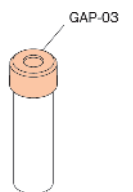
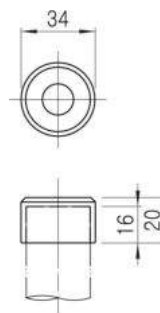

GAP-4P Inner Cap



Material	LDPE
Weight	0.003kg
Q'ty/Box	1500pcs

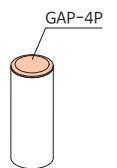
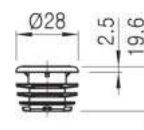

PLASTIC JOINTS

COLOR : Ivory  Gray  Green  Esd 

Unit : mm

MRS

GAP-4C/4S Inner Cap



Material	LDPE
Weight	0.003kg
Q'ty/Box	1500pcs

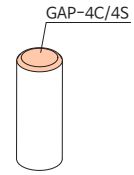
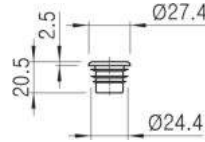

GAP-4R Rubber Cap



Material	TPU
Weight	0.009kg
Q'ty/Box	900pcs

* Color : BK

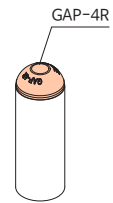
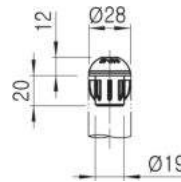

GAP-5 Plastic Joint Corner



Material	ASA
Weight	0.032kg
Q'ty/Box	150pcs

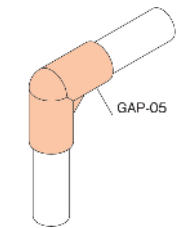
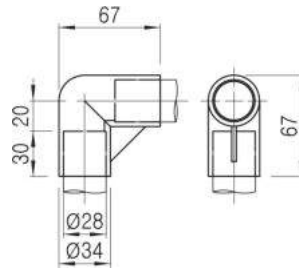

GAP-6 Label Holder



Material	ABS
Weight	0.005kg
Q'ty/Box	1200pcs

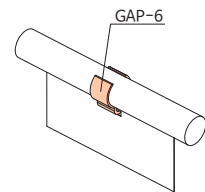
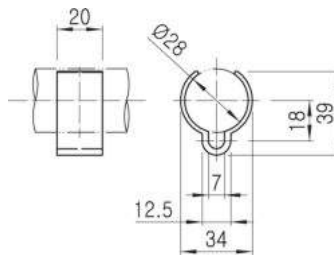

GAP-6B Label Holder



Material	ABS
Weight	0.005kg
Q'ty/Box	1200pcs

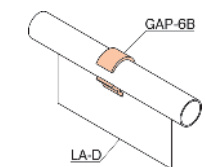
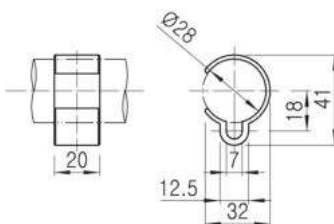

PLASTIC JOINTS

COLOR : Ivory  Gray  Green  Esd 

Unit : mm

MRS

GAP-7 Plastic Joint



Material	ABS
Weight	0.011kg
Q'ty/Box	450pcs

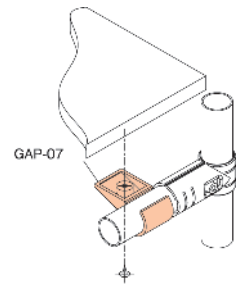
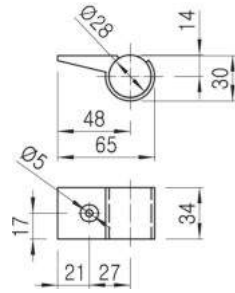

GAP-8 Horizontal Holder



Material	ABS
Weight	0.005kg
Q'ty/Box	1200pcs

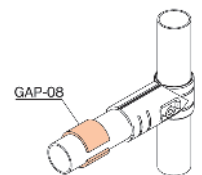
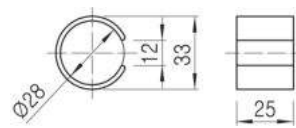

GAP-8FN Horizontal Holder (Flat Type)



Material	ABS
Weight	0.005kg
Q'ty/Box	1200pcs

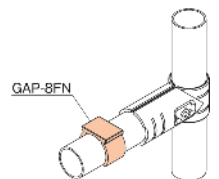
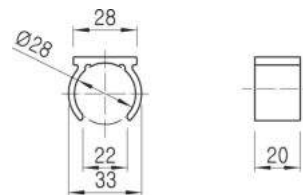

GAP-9C-07 Grip Bushing (Coating Pipe:Ø28×T0.7)



Material	NYLON66
Weight	0.016kg
Q'ty/Box	450pcs

* Color : BK

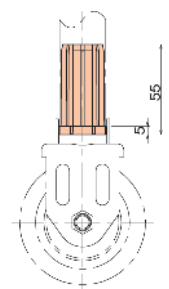
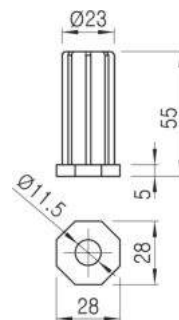

GAP-9C-09 Grip Bushing (Coating Pipe:Ø28×T0.9)



Material	NYLON66
Weight	0.016kg
Q'ty/Box	450pcs

* Color : BK

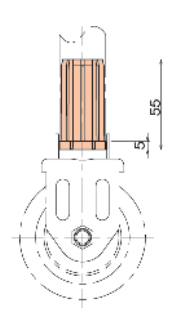
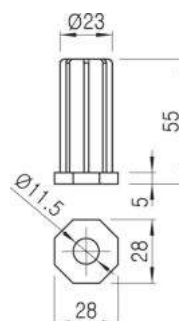

PLASTIC JOINTS

COLOR : Ivory  Gray  Green  Esd 

Unit : mm

GAP-9S-07 Grip Bushing (STS Pipe: $\varnothing 28 \times T 0.7$)



Material	NYLON66
Weight	0.016kg
Q'ty/Box	450pcs

* Color : BK

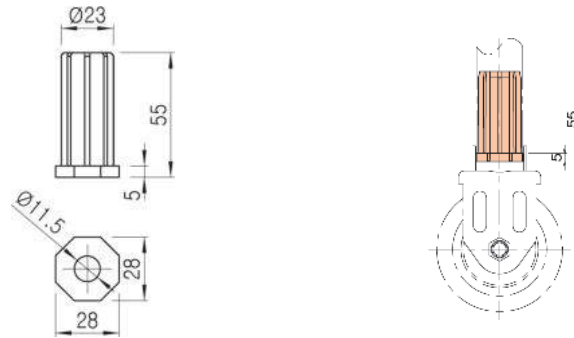

GAP-10R Plastic Joint (Right side handle)



Material	ASA
Weight	0.042kg
Q'ty/Box	120pcs

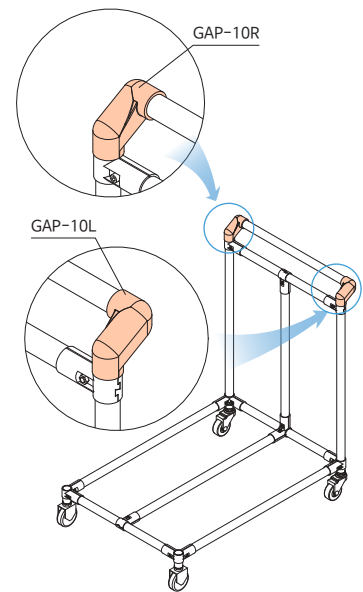
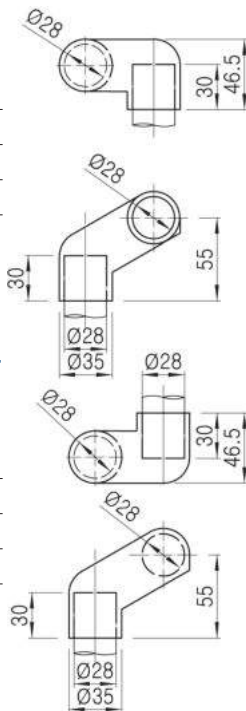

GAP-10L Plastic Joint (Left side handle)



Material	ASA
Weight	0.042kg
Q'ty/Box	120pcs

GAP-11 Taper Edge



Material	ABS
Weight	0.005kg
Q'ty/Box	250pcs

Box 등 이동시 Joint 에 걸림을 방지하기 위한 제품임

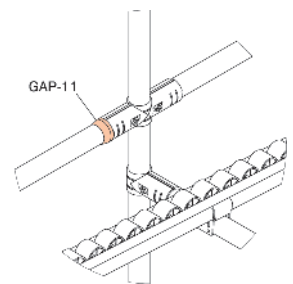
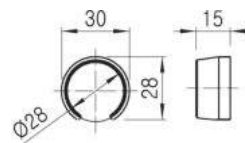

GAP-12 Sleeve (For GA-12S/17S/18S/24S/25S)



Material	PE
Weight	0.007kg
Q'ty/Box	600pcs

* Color : White

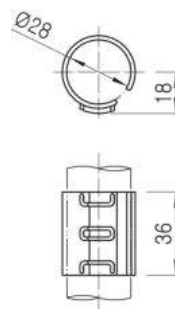

PLASTIC JOINTS

COLOR : Ivory  Gray  Green  Esd 

Unit : mm

MRS

GAP-13 Plastic Joint Corner



Material	ABS
Weight	0.059kg
Q'ty/Box	75pcs

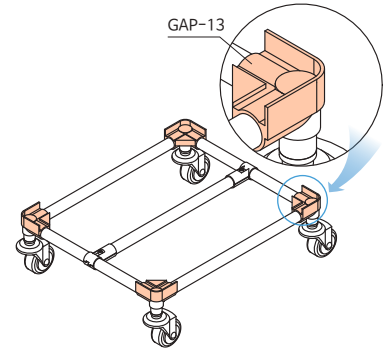
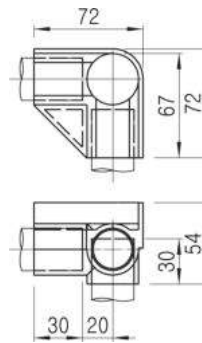

GAP-14 Plastic Joint Corner Cushion Type



Material	ASA
Weight	0.075kg
Q'ty/Box	75pcs

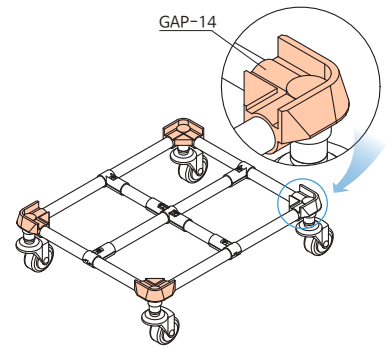
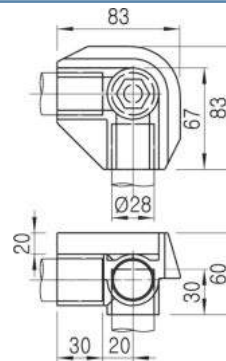

GAP-15 Sheet Holder



Material	ABS
Weight	0.003kg
Q'ty/Box	1500pcs

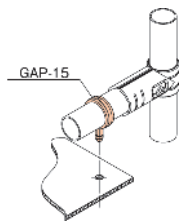
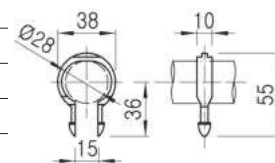

GAP-16 Plastic Joint



Material	ASA
Weight	0.018kg
Q'ty/Box	300pcs

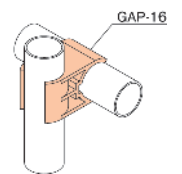
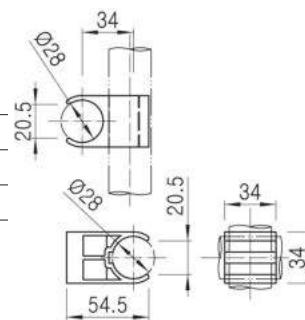

GAP-17 Plastic Joint



Material	ABS
Weight	0.014kg
Q'ty/Box	400pcs

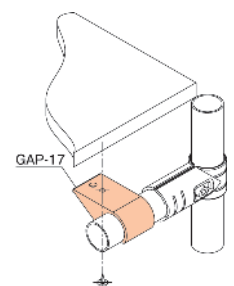
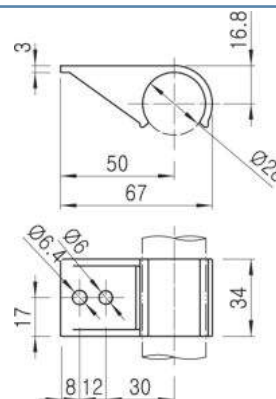

PLASTIC JOINTS

COLOR : Ivory  Gray  Green  Esd 

Unit : mm

MRS

GAP-18A Plastic Joint



Material	ASA
Weight	0.023kg
Q'ty/Box	240pcs

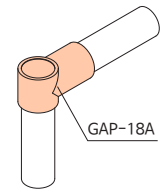
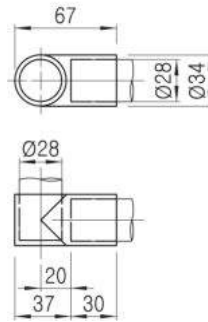

GAP-18B Plastic Joint (Penetrated Model)



Material	ASA
Weight	0.022kg
Q'ty/Box	240pcs

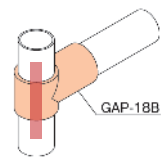
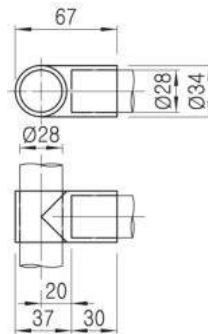

GAP-19 Plastic Joint



Material	ASA
Weight	0.009kg
Q'ty/Box	750pcs

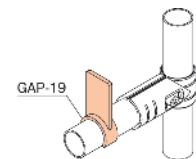
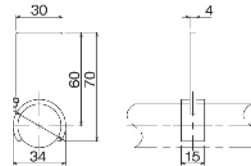

GAP-20 Name Plate Holder



Material	ABS
Weight	0.006kg
Q'ty/Box	1200pcs

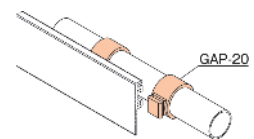
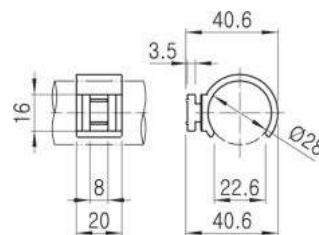

GAP-23 Plastic Joint

Bolt & Nut included



Material	ABS
Weight	0.020kg
Q'ty/Box	1500pcs

Bolt : M3x20
Nut : M3

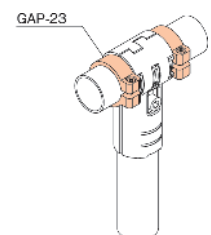
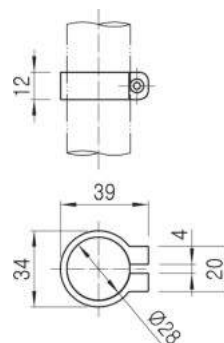

PLASTIC JOINTS

COLOR : Ivory  Gray  Green  Esd 

Unit : mm

GAP-24A Plastic Joint



Material	ASA
Weight	0.060kg
Q'ty/Box	75pcs

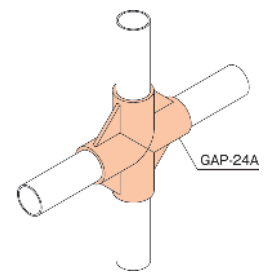
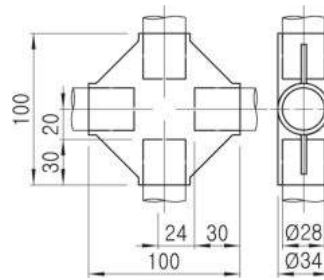

GAP-24B Plastic Joint (Penetrated Model)



Material	ASA
Weight	0.057kg
Q'ty/Box	75pcs

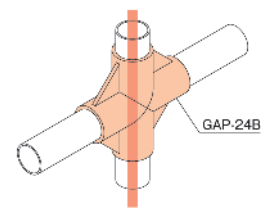
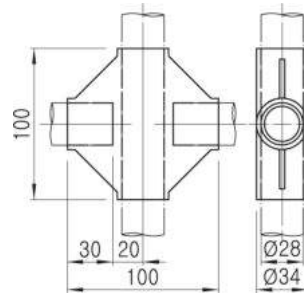

GAP-25A Plastic Joint



Material	ASA
Weight	0.075kg
Q'ty/Box	45pcs

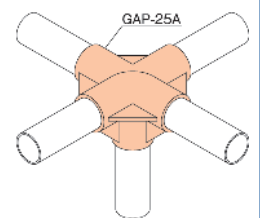
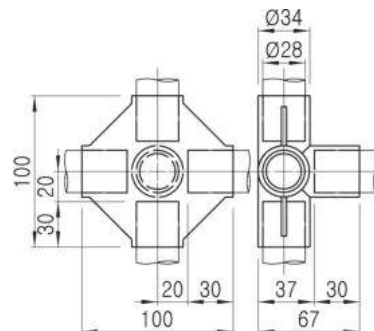

GAP-25B Plastic Joint (Penetrated Model)



Material	ASA
Weight	0.072kg
Q'ty/Box	45pcs

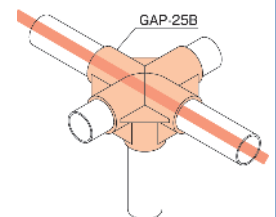
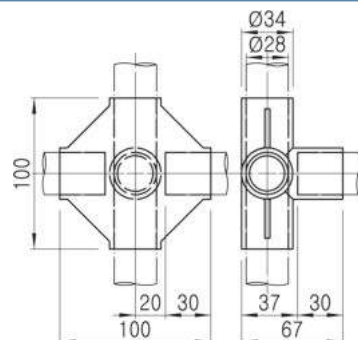

GAP-26A Plastic Joint



Material	ASA
Weight	0.055kg
Q'ty/Box	75pcs

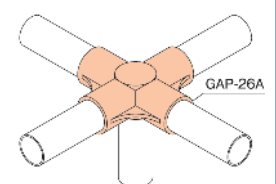
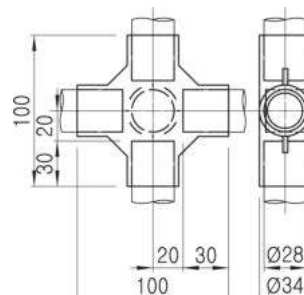

PLASTIC JOINTS

COLOR : Ivory  Gray  Green  ESD 

Unit : mm

MRS

GAP-26B Plastic Joint (Penetrated Model)



Material	ASA
Weight	0.054kg
Q'ty/Box	75pcs

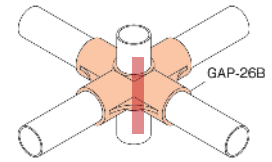
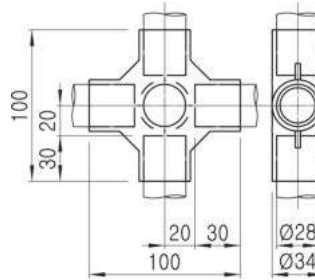

GAP-27A Plastic Joint



Material	ASA
Weight	0.035kg
Q'ty/Box	150pcs

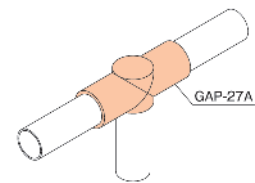
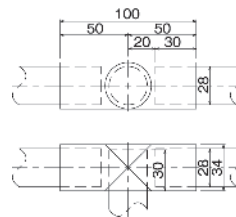

GAP-27B Plastic Joint (Penetrated Model)



Material	ASA
Weight	0.033kg
Q'ty/Box	150pcs

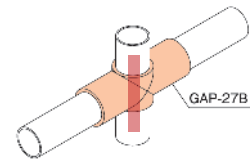
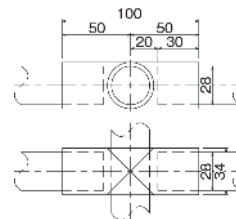

GAP-28A Plastic Joint



Material	ASA
Weight	0.046kg
Q'ty/Box	90pcs

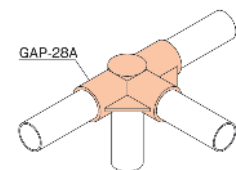
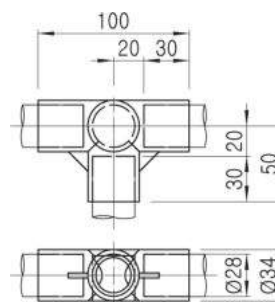

GAP-28B Plastic Joint (Penetrated Model)



Material	ASA
Weight	0.044kg
Q'ty/Box	90pcs

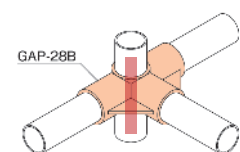
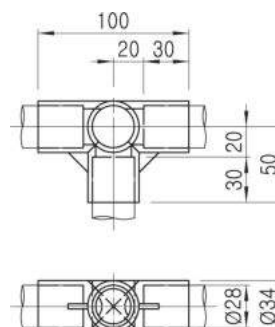

PLASTIC JOINTS

COLOR : Ivory  Gray  Green  Esd 

Unit : mm

GAP-29A Plastic Joint



Material	ASA
Weight	0.045kg
Q'ty/Box	90pcs

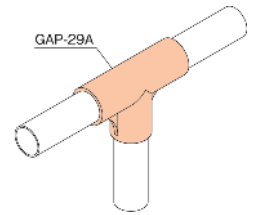
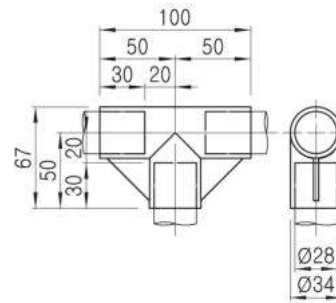

GAP-29B Plastic Joint (Penetrated Model)



Material	ASA
Weight	0.043kg
Q'ty/Box	90pcs

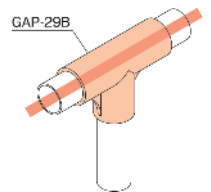
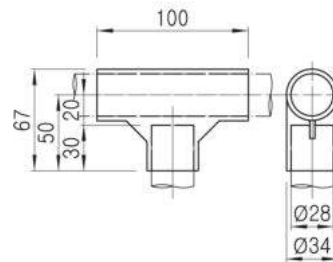

GAP-30A Plastic Joint



Material	ASA
Weight	0.026kg
Q'ty/Box	210pcs

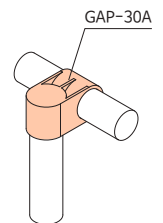
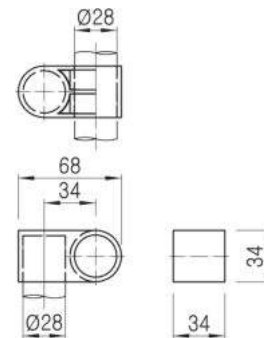

GAP-30B Plastic Joint



Material	ASA
Weight	0.025kg
Q'ty/Box	210pcs

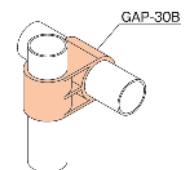
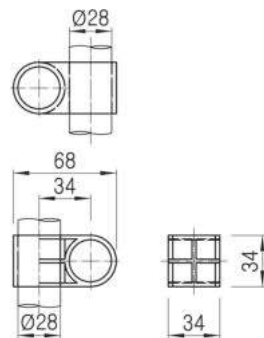

GAP-31 Plastic Joint



Material	ASA
Weight	0.020kg
Q'ty/Box	210pcs

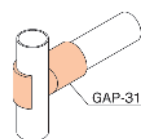
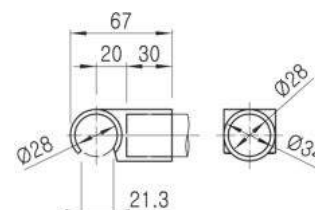

PLASTIC JOINTS

COLOR : Ivory  Gray  Green  Esd 

Unit : mm

MRS

GAP-34 Plastic Joint



Material	ASA
Weight	0.014kg
Q'ty/Box	500pcs

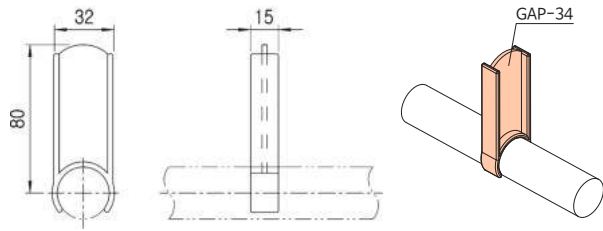

GAP-35 Plastic Joint



Material	NYLON66
Weight	0.015kg
Q'ty/Box	300pcs

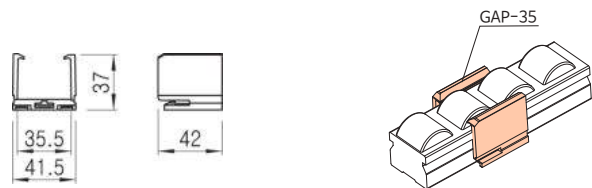

GAP-37A Plastic Joint

Bolt & Nut sold separately



Material	ABS
Weight	0.011kg
Q'ty/Box	600pcs

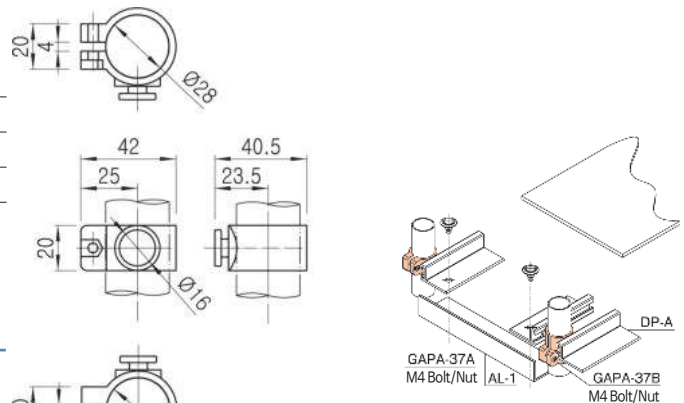

GAP-37B Plastic Joint

Bolt & Nut sold separately



Material	ABS
Weight	0.019kg
Q'ty/Box	300pcs

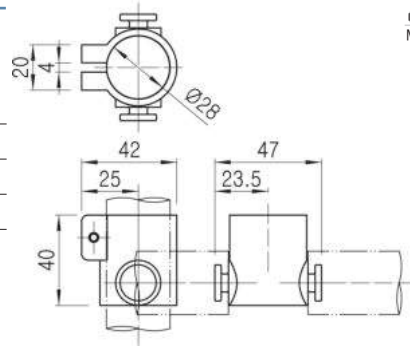

GAP-39 Plastic Joint



Material	PP
Weight	0.047kg
Q'ty/Box	120pcs

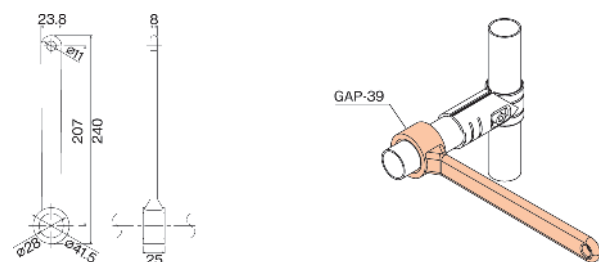

PLASTIC JOINTS

COLOR : Ivory  Gray  Green  Esd 

Unit : mm

MRS

GAP-40 Plastic Joint



Material	NYLON66
Weight	0.034kg
Q'ty/Box	150pcs

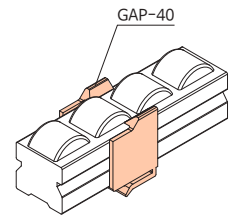
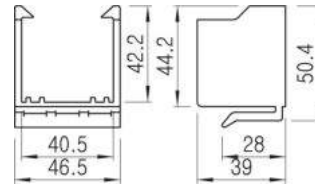

GAP-41 Plastic Joint



Material	ASA
Weight	0.030kg
Q'ty/Box	150pcs

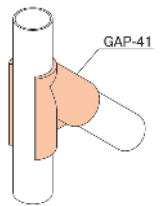
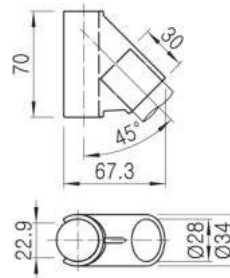

GAP-42 Plastic Joint



Material	ASA
Weight	0.045kg
Q'ty/Box	90pcs

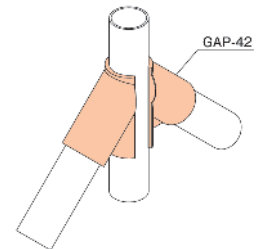
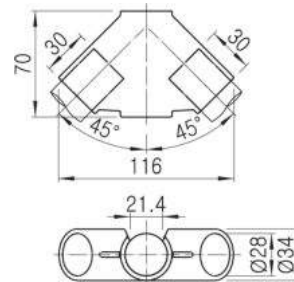

GAP-43 Plastic Joint



Material	NYLON6
Weight	0.028kg
Q'ty/Box	150pcs

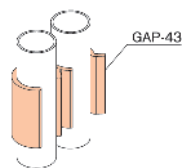
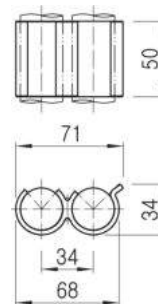

GAP-44 Sleeve (For GA-12S/17S/18S/24S/25S)



Material	PE
Weight	0.012kg
Q'ty/Box	200pcs

* Color : White

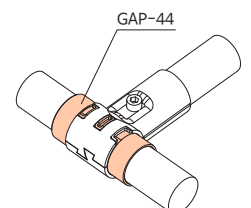
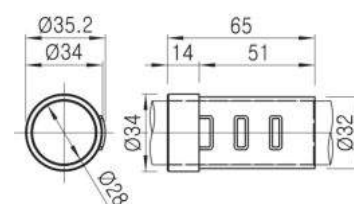

PLASTIC JOINTS

COLOR : Ivory  Gray  Green  Esd 

Unit : mm

GAP-45A Plastic Joint



Material	ASA
Weight	0.060kg
Q'ty/Box	75pcs

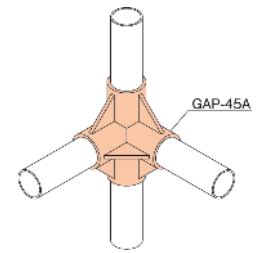
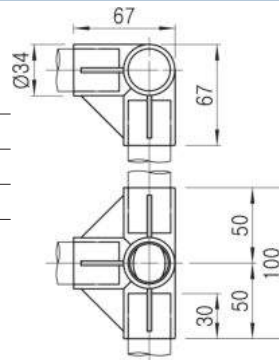

GAP-45B Plastic Joint (Penetrated Model)



Material	ASA
Weight	0.060kg
Q'ty/Box	75pcs

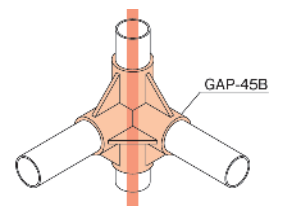
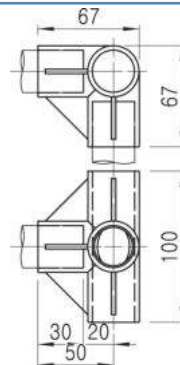

GAP-46 Plastic Joint



Material	ABS
Weight	0.013kg
Q'ty/Box	450pcs

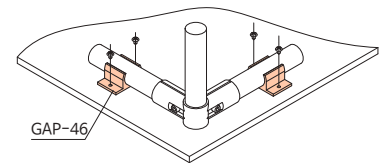
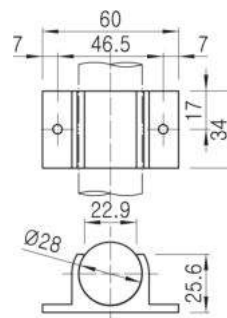

GAP-47 Plastic Joint (Length adjustment)



Material	ABS
Weight	0.030kg
Q'ty/Box	180pcs

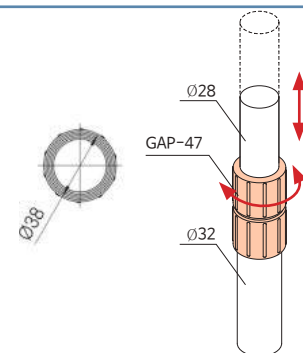
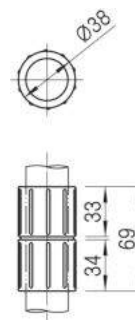

GAP-53 Plastic Joint



Material	ASA
Weight	0.014kg
Q'ty/Box	450pcs

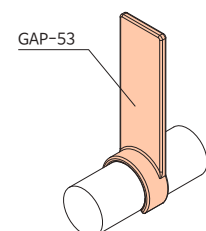
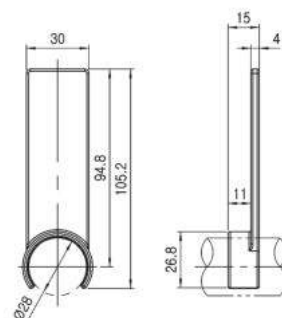

PLASTIC JOINTS

COLOR : Ivory  Gray  Green  Esd 

Unit : mm

MRS

GAP-48 Roller Conveyor Holder (Single)



Material	ASA
Weight	0.013kg
Q'ty/Box	500pcs

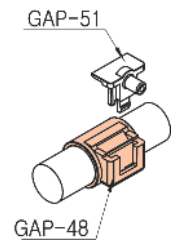
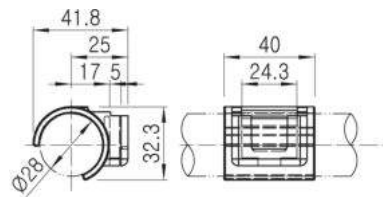

GAP-49 Roller Conveyor Holder (Double)



Material	ASA
Weight	0.017kg
Q'ty/Box	400pcs

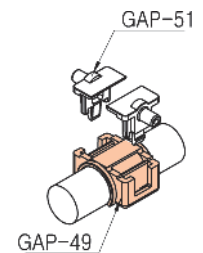
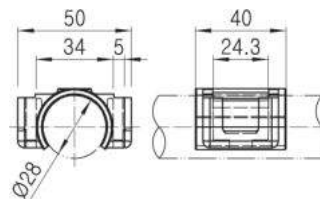

GAP-50 Roller Conveyor Cap (Without Bearing)



Material	POM
Weight	0.008kg
Q'ty/Box	1200pcs

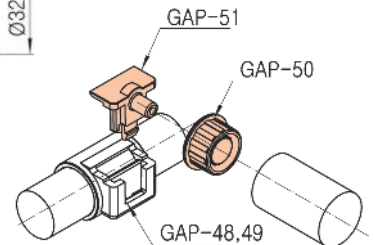
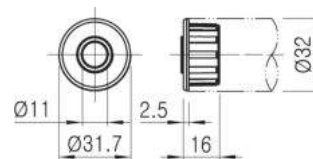

GAP-51 Roller Conveyor Support



Material	POM
Weight	0.007kg
Q'ty/Box	1200pcs

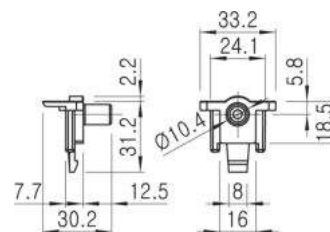

GAP-52A Roller Conveyor Cap (With Bearing)



Material	ABS
Weight	0.013kg
Q'ty/Box	1500pcs

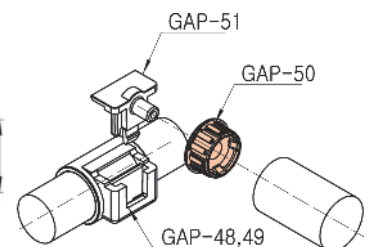
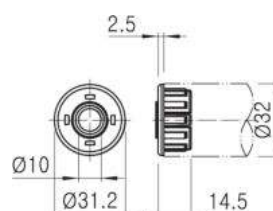

PLASTIC JOINTS

COLOR : Ivory  Gray  Green  Esd 

Unit : mm

GAP-54 Plastic Joint



Material	ASA
Weight	0.025kg
Q'ty/Box	150pcs

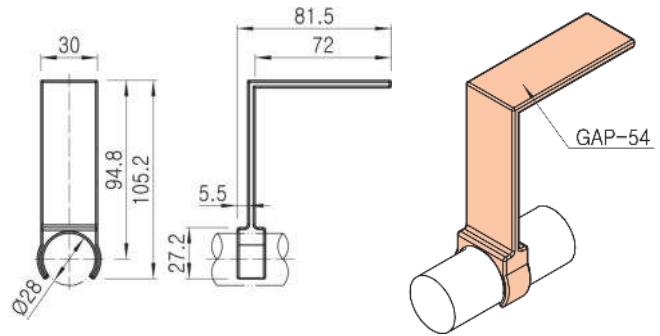

GAP-55 Name Plate Holder (Assemble with NP-B or NP-M)

Bolt & Nut sold separately



Material	ABS
Weight	0.009kg
Q'ty/Box	750pcs

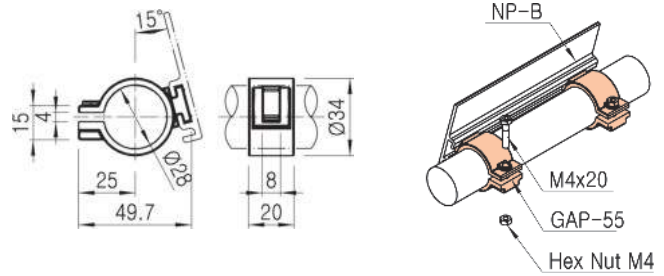

GAP-56 Sleeve (For GA-35S)



Material	PE
Weight	0.010kg
Q'ty/Box	300pcs

* Color : White

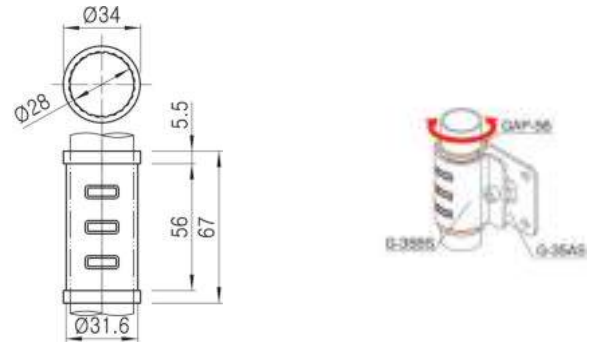

GAP-58 Name Plate Holder (Assemble with NP-F)

*Name Plate rotating prevention



Material	PVC
Weight	0.008kg
Q'ty/Box	900pcs

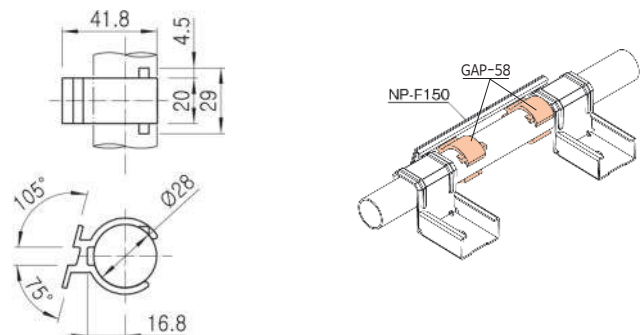

GAP-61 Plastic Joint



Material	ABS
Weight	0.015kg
Q'ty/Box	400pcs

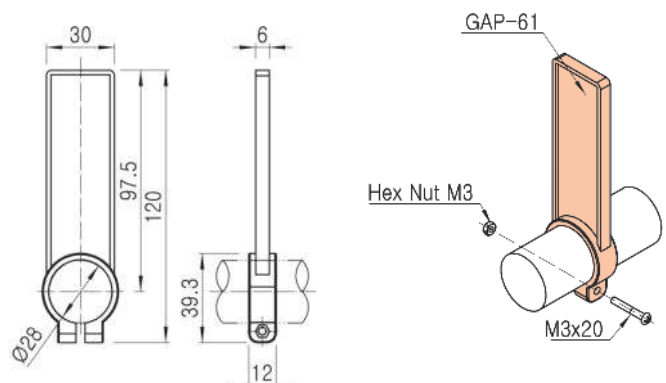

PLASTIC JOINTS

COLOR : Ivory  Gray  Green  Esd 

Unit : mm

MRS

GAP-64 Corner Support Joint



Patented

Material	ASA
Weight	0.165kg
Q'ty/Box	38pcs

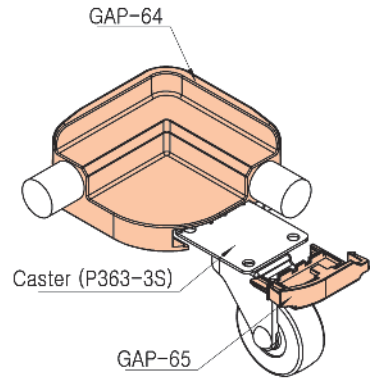
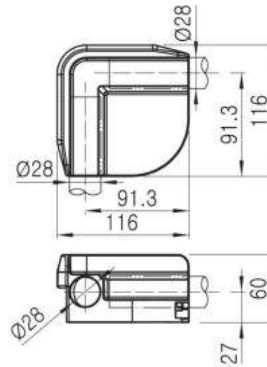

GAP-65 Corner Support Cap



Patented

Material	ABS
Weight	0.015kg
Q'ty/Box	400pcs

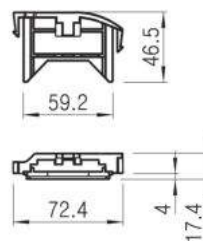

GAP-66 Plastic Joint



Material	ABS
Weight	0.022kg
Q'ty/Box	200pcs

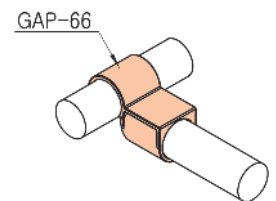
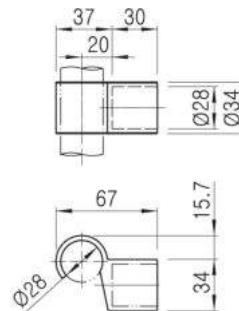

GAP-71 Plastic Joint



Material	ASA
Weight	0.029kg
Q'ty/Box	150pcs

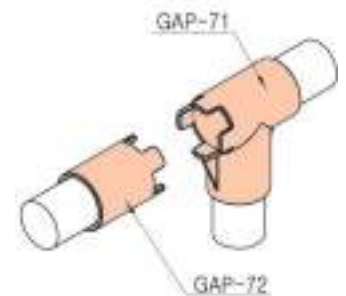
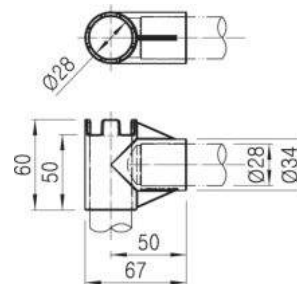

GAP-72 Plastic Joint



Material	ASA
Weight	0.014kg
Q'ty/Box	300pcs

After fixing GAP-72 to the Pipe, GAP-71 can be disassembled from GAP-72, 90° rotated and, assembled with GAP-72 again.

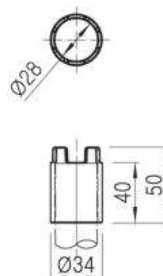

PLASTIC JOINTS

COLOR : Ivory  Gray  Green  Esd 

Unit : mm

MRS

GAP-73 Plastic Latch



Material	TPU
Weight	0.033kg
Q'ty/Box	300pcs

* Color : Yellow

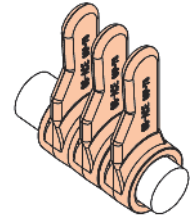
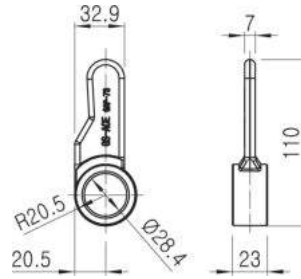

GAP-74A Plastic Latch



Material	TPU
Weight	0.028kg
Q'ty/Box	300pcs

* Color : Yellow

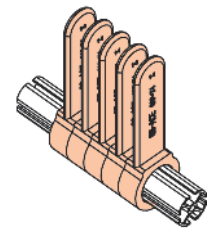
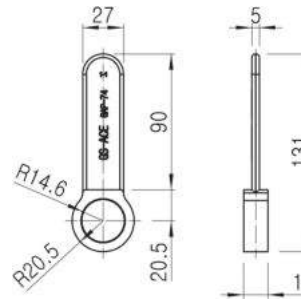

GAP-74B Plastic Latch



Material	TPU
Weight	0.028kg
Q'ty/Box	300pcs

* Color : Yellow

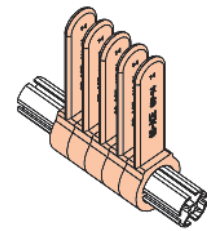
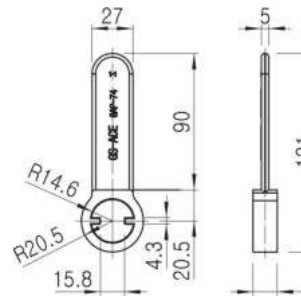

GAP-75 Plastic Latch

Bolt & Nut sold separately



Material	ABS
Weight	0.012kg
Q'ty/Box	400pcs

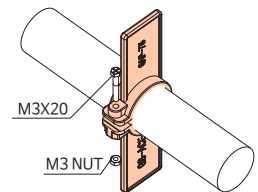
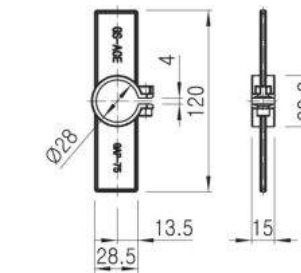

GAPA-76A Swivel Plastic Joint Ass'y



Material	ASA
Weight	0.015kg
Q'ty/Box	100pcs

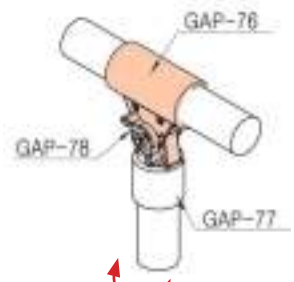
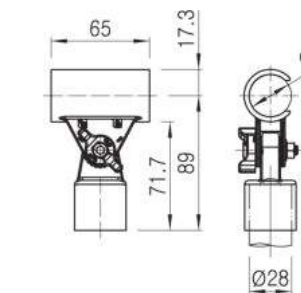

각도 조절후 고정

PLASTIC JOINTS

COLOR : Ivory  Gray  Green  Esd 

Unit : mm

MRS

GAP-79 Plastic Latch



Material	TPU(우레탄)
Weight	0.047kg
Q'ty/Box	150pcs

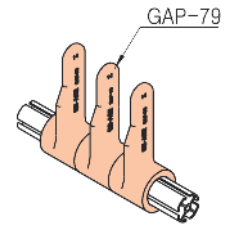
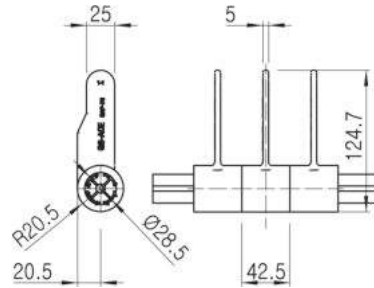

GAP-80A Plastic Latch



Material	TPU(우레탄)
Weight	0.024kg
Q'ty/Box	300pcs

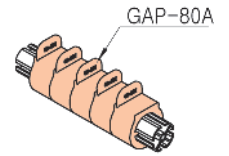
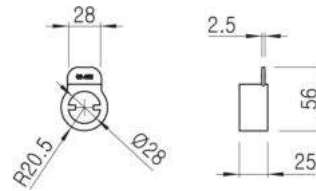

GAP-80B Plastic Latch



Material	TPU(우레탄)
Weight	0.016kg
Q'ty/Box	450pcs

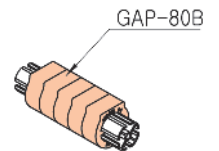
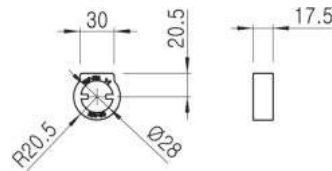

GAP-81 Plastic Latch



Material	TPU(우레탄)
Weight	0.027kg
Q'ty/Box	210pcs

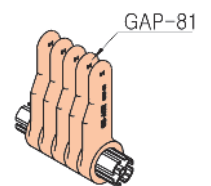
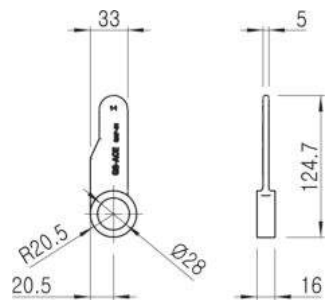

GAP-82 Plastic Latch



Material	TPU(우레탄)
Weight	0.026kg
Q'ty/Box	210pcs

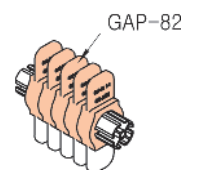
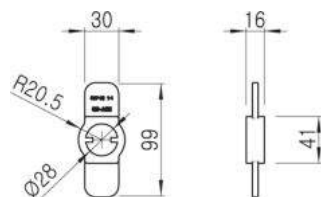

PLASTIC JOINTS

COLOR : Ivory  Gray  Green  ESD 

Unit : mm

MRS

GAP-83 Plastic Joint



Material	ASA
Weight	0.044kg
Q'ty/Box	90pcs

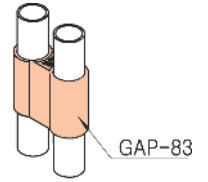
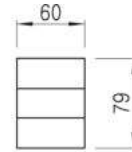
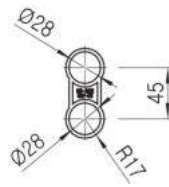

GAP-84 Plastic Joint



Material	ASA
Weight	0.048kg
Q'ty/Box	90pcs

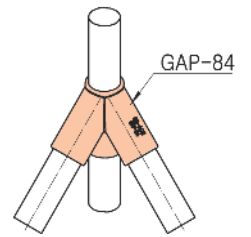
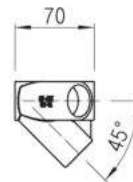
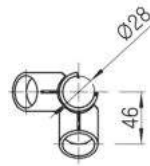

ALUMINUM RACKING SYSTEM

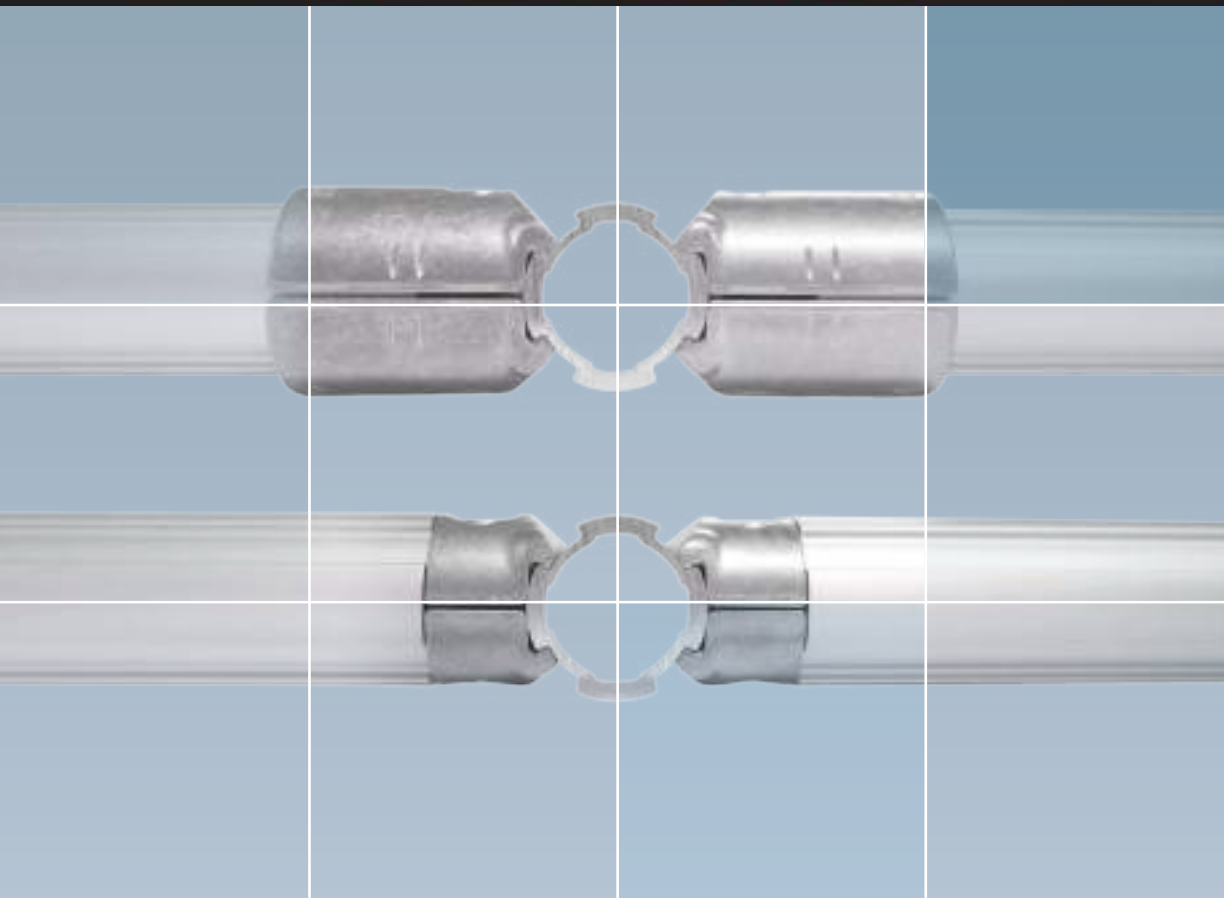

- ϕ 28 ALUMINUM RACKING SYSTEM
- ϕ 33 ALUMINUM RACKING SYSTEM
- ϕ 43 ALUMINUM RACKING SYSTEM
- 28X28 ALUMNUM RACKING SYSTEM
- 40X40 AL PROFILE RACKING SYSTEM
- 45X45 AL PROFILE RACKING SYSTEM

AL RACKING SYSTEM

FEATURES OF ALUMINUM PIPE

G.S. ACE introduces a new revolutionary Aluminum Racking System to compliment our current product offerings.

The highlights of the new products are:

- ◆ Aluminum Racking System can be integrated in our traditional Pipe Racking System.
All of Metal Joints, Mounting Bracket, and Other Accessories can be used in newly introduced Aluminum Racking System.
- ◆ Inner type joints will be flush with the aluminum pipe which will provide counter top panel a continuous support. (Fig 1)
- ◆ High esthetic value without glaring
- ◆ High strength to weight ratio (1/3 of welded structures)
- ◆ Can be used in clean room.
- ◆ Aluminum is environmentally friendly and retains high recycling value (up to 50% of aluminum market value)

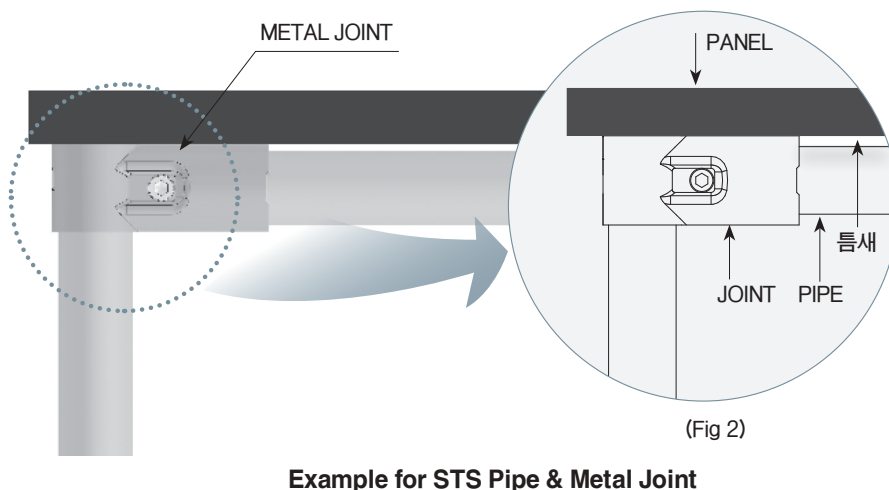
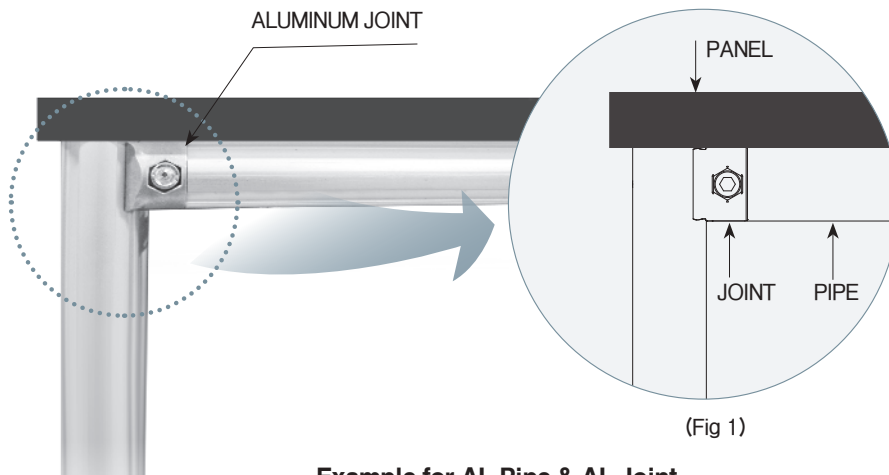

Ø28 AL RACKING SYSTEM

Ø28 ALUMINUM PIPE

AP2812

Regular Duty Pipe

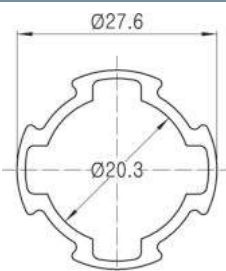

- Weight: 0.382kg/m, O.D. Ø28

AP2820

Light Heavy Duty Pipe

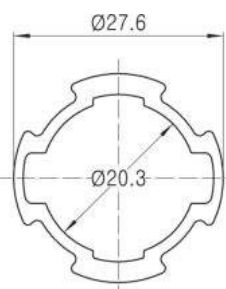

- Weight: 0.450kg/m, O.D. Ø28

AP2829

Heavy Duty Pipe

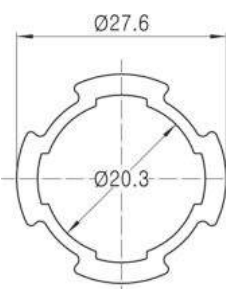

- Weight: 0.500kg/m, O.D. Ø28

AP2812H

Extra Heavy Duty Pipe

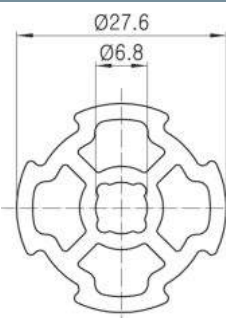

- Weight: 0.741kg/m, O.D. Ø28

AQ2812

Hand Rail Pipe

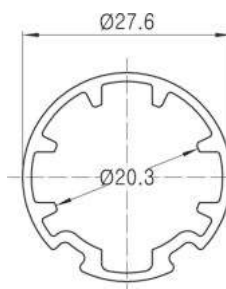

- Weight : 0.374kg/m, O.D. Ø28

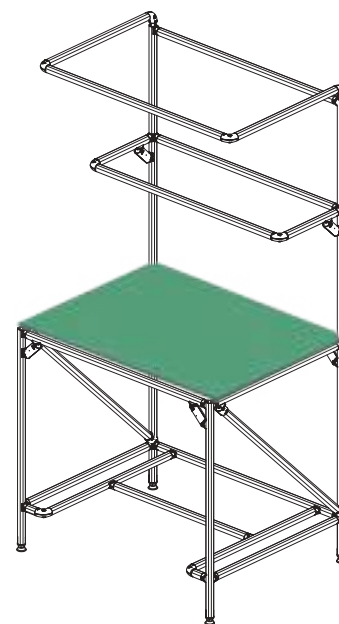

Ø28 AL RACKING SYSTEM

AL2813 Round Pipe (For Metal Joint)

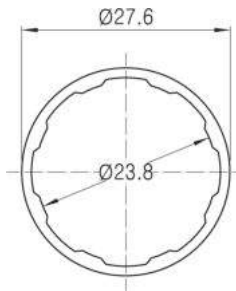

- Weight: 0.335kg/m, O.D. Ø28

AL2818 Round Pipe (For Metal Joint)

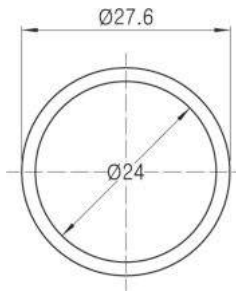

- Weight: 0.401kg/m, O.D. Ø28

AR2812 Round Pipe (Regular Duty)

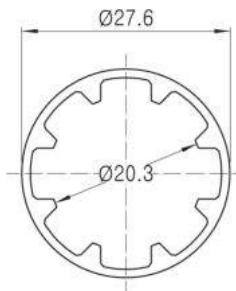

- Weight: 0.379kg/m, O.D. Ø28

AR2820 Round Pipe (Light Heavy Duty)

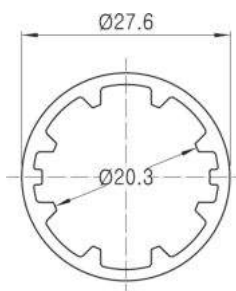

- Weight: 0.446kg/m, O.D. Ø28

AR2829 Round Pipe (Heavy Duty)

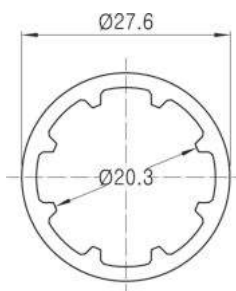

- Weight: 0.496kg/m, O.D. Ø28

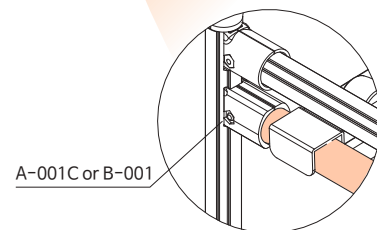
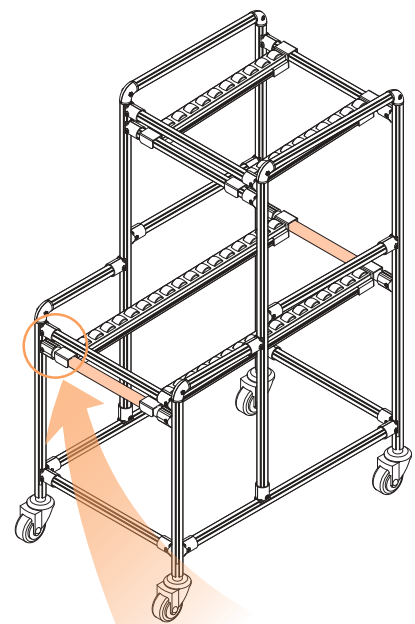
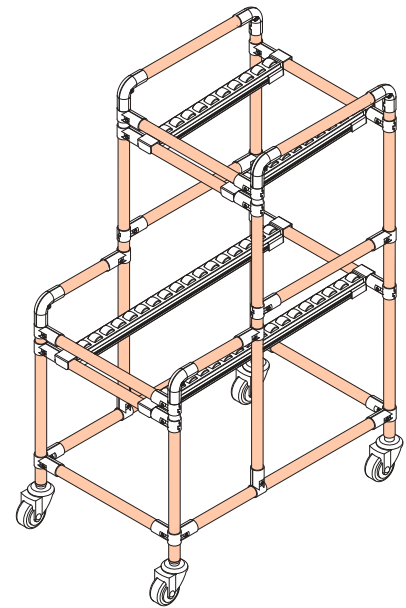

VIEW

Ø28 AL RACKING SYSTEM

AD2812

Heavy Duty Double Pipe



- Weight: 0.761kg/m, 외경 Ø28

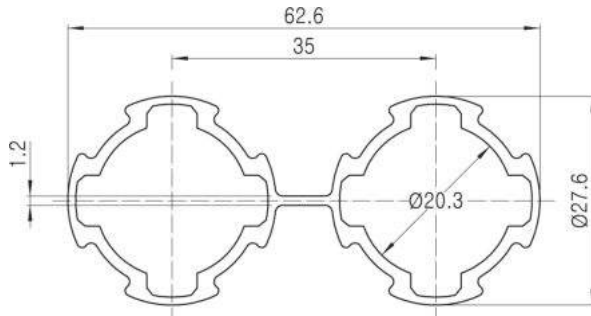

AD2829

Extra Heavy Duty Double Pipe



- Weight: 1.138kg/m, O.D. Ø28

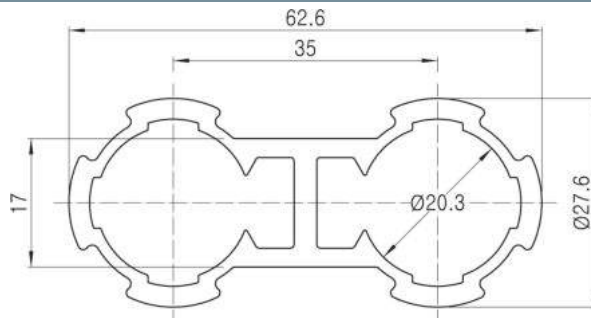

AD2812H

Extra Heavy Duty Double Pipe



- Weight: 1.372kg/m, O.D. Ø28

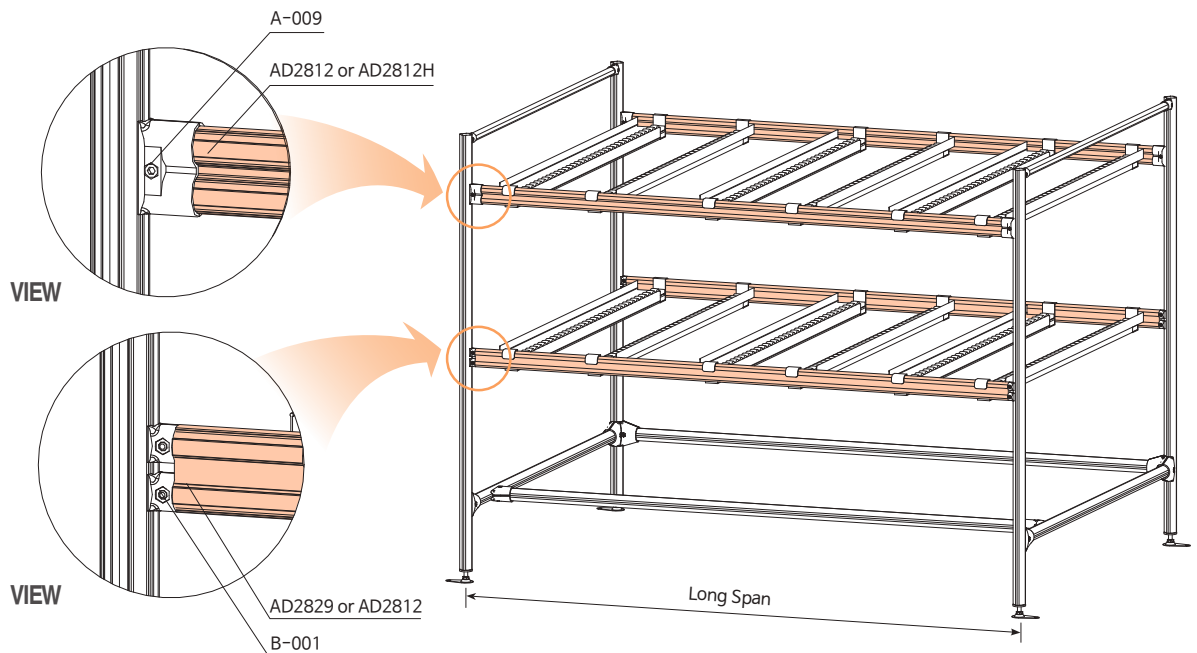
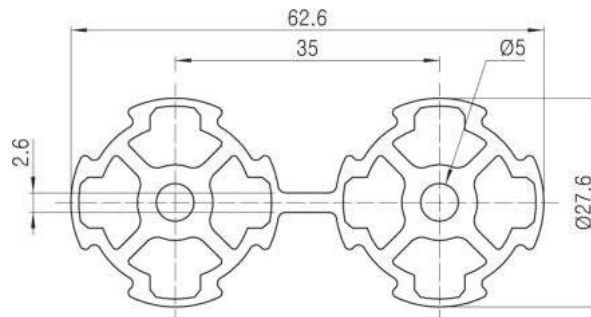

Ø28 AL RACKING SYSTEM

ALS2812 L-Slide Pipe



- Weight: 0.372kg/m, O.D. Ø28

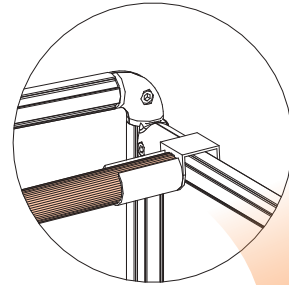
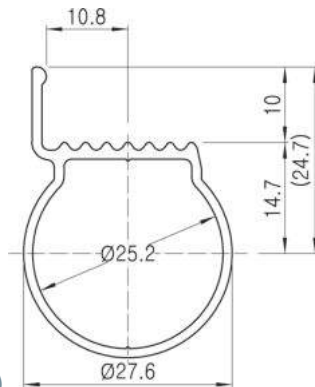

AFS2810 Full Slide Pipe (Light Duty)



- Weight : 0.375kg/m, O.D. Ø28

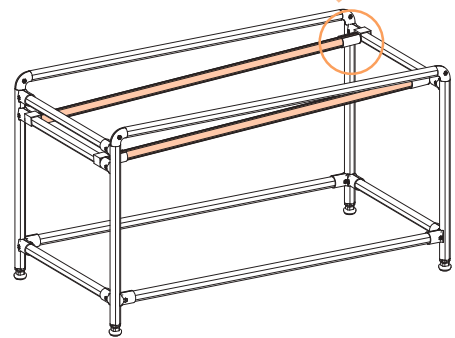
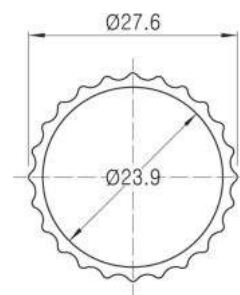

AFS2812 Full Slide Pipe (Regular Duty)



- Weight: 0.408kg/m, O.D. Ø28

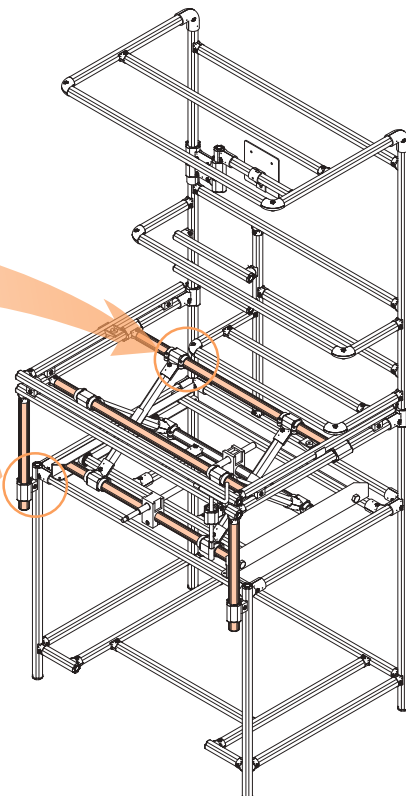
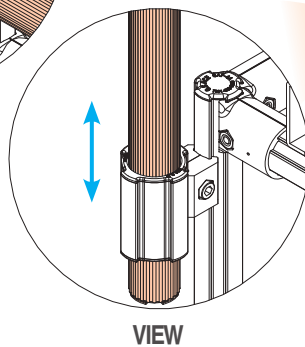
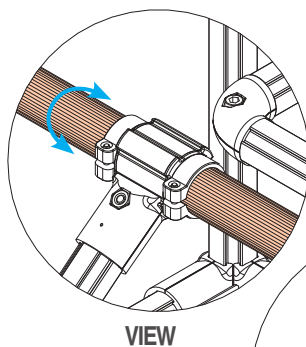
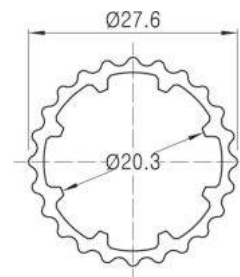

Ø28 AL RACKING SYSTEM

AGP-28A

Panel Frame Guide AL Pipe



- Weight: 0.479kg/m, O.D. Ø28

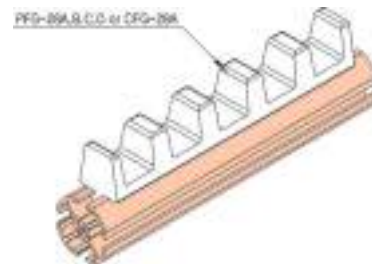
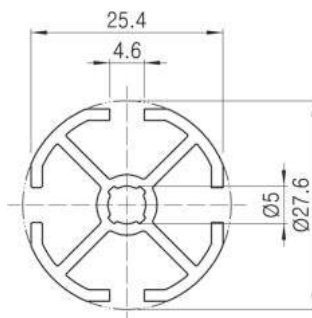

AGP-28B

Panel Frame Guide AL Pipe



- Weight: 0.498kg/m, O.D. Ø28

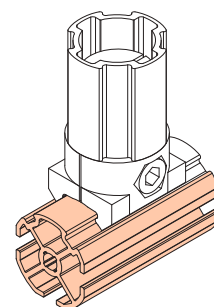
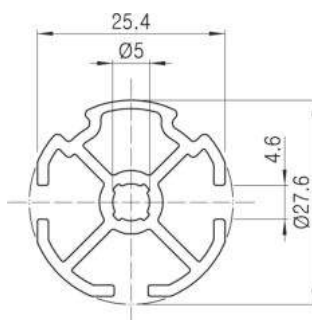

PGC-28A

Groove Cover (For AGP-28A/B)



- Weight: 0.038kg/m

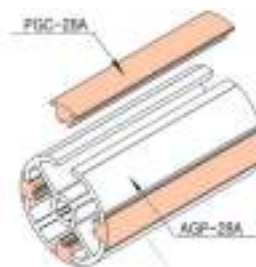
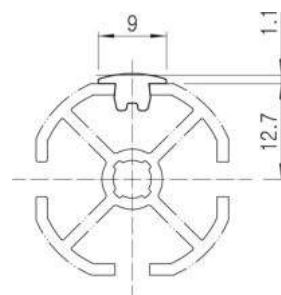

PGC-28B

Groove Cover (For AGP-28A/B)



- Weight: 0.102kg/m

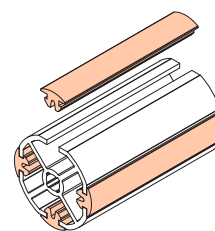
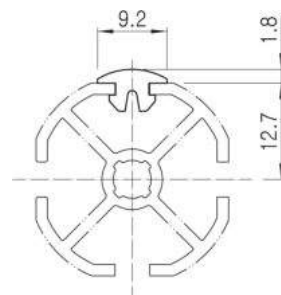

PGT-28B

Groove Cover (For AGP-28A/B)



- Weight: 0.102kg/m

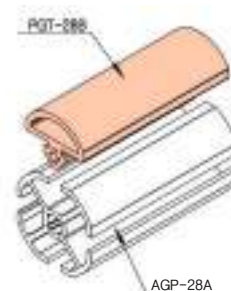
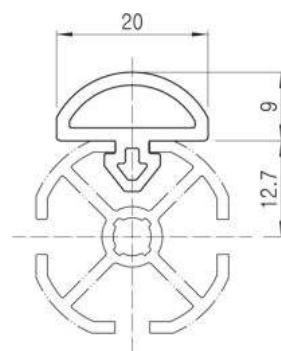

Ø28 AL RACKING SYSTEM

AT2829

T Slot Pipe

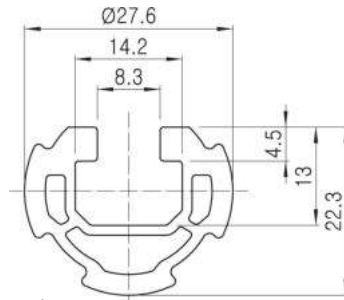

- Weight: 0.595kg/m, O.D. Ø28
- ※ Spring Nuts can be used in the slot to attach various items
- ※ Slot will facilitate the linear movement of attached item

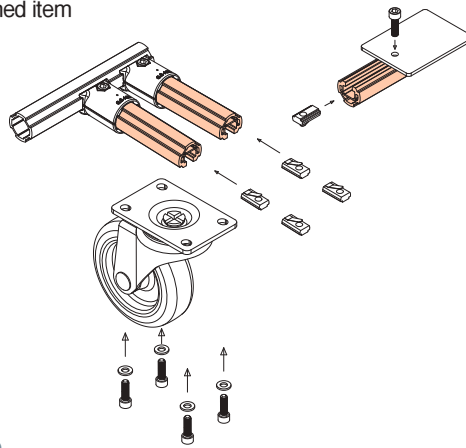

ASGP-08

Panel Guide Pipe

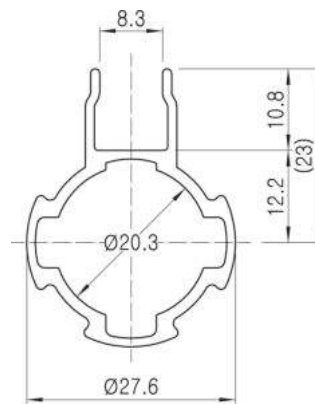

- Weight : 0.445kg/m
- Q'ty/Bundle : 8pcs
- Standard Length : 4MT

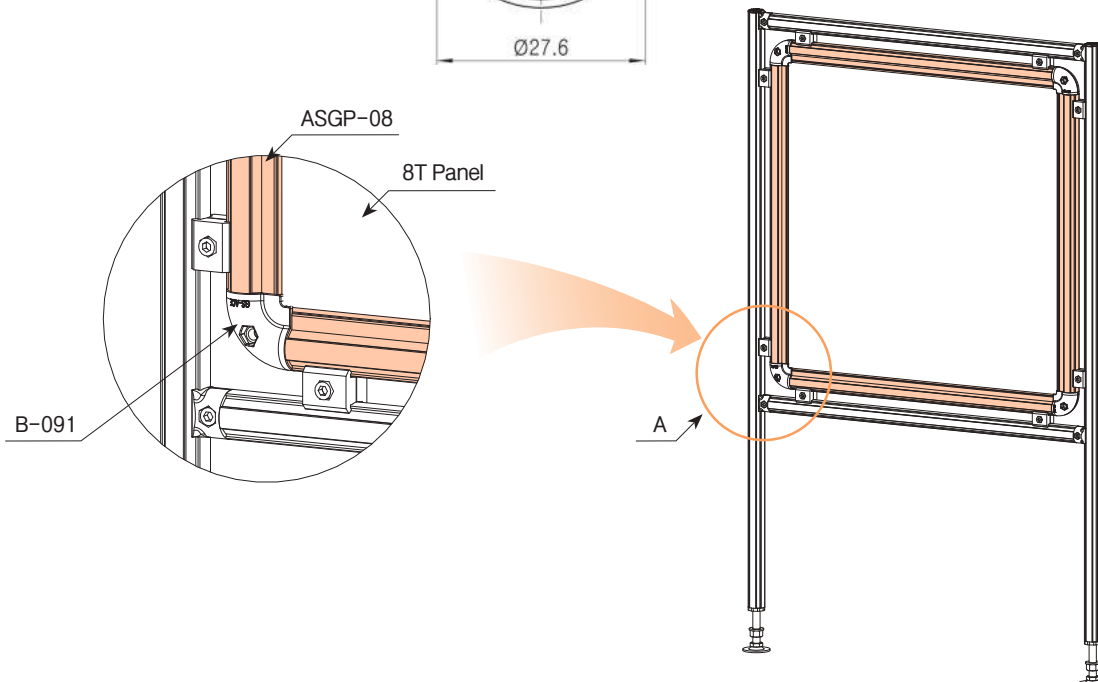

Ø28 AL RACKING SYSTEM

ACF2812

Flat Pipe



• Weight : 0.358kg/m, O.D. Ø28

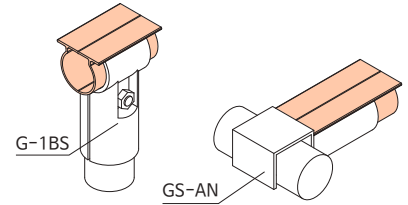
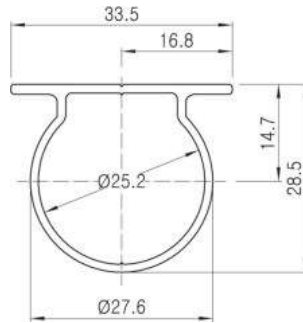

ATF2812

T-Flat Pipe



• Weight : 0.685kg/m, O.D. Ø28

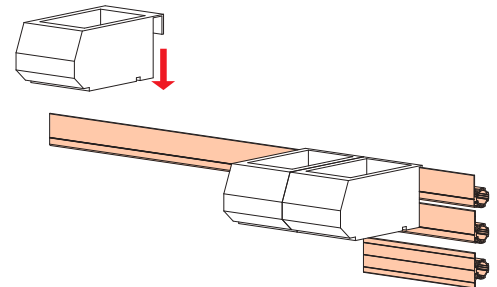
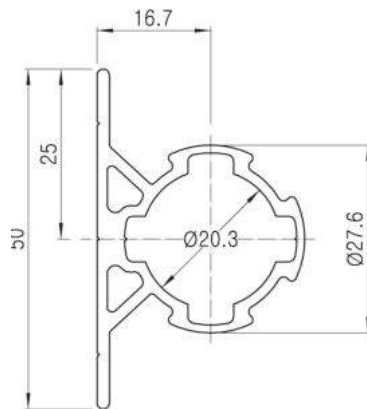

ALF2812

L-Flat Pipe



• Weight : 0.655kg/m, O.D. Ø28

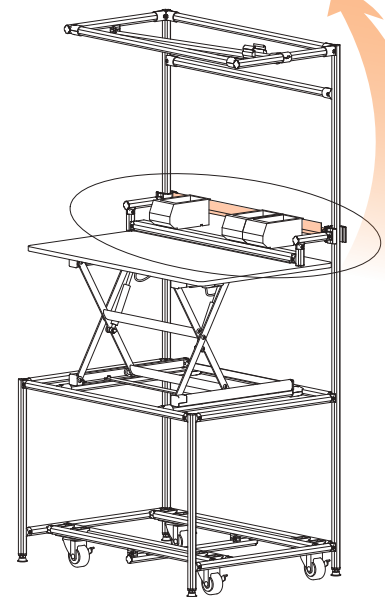
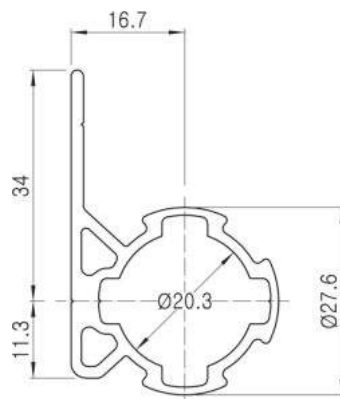

ALF2812B

L-Flat Pipe



• Weight : 0.614kg/m, O.D. Ø28

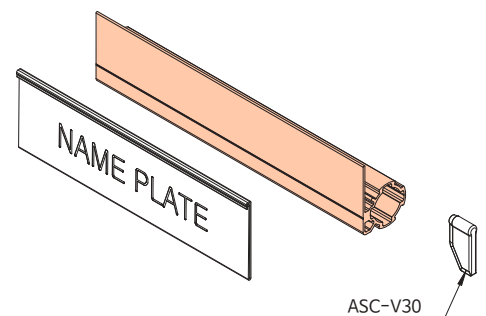
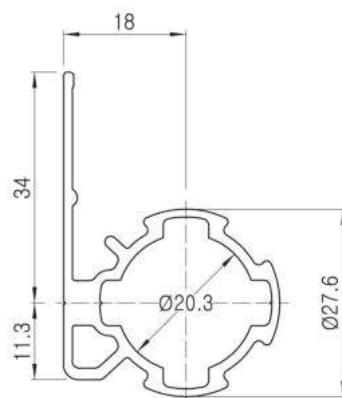

Ø28 AL RACKING SYSTEM

Ø28 ALUMINUM JOINTS

◆ Outer Joints (Patented)

A-001

Single Tee Joint



<AA-001>

- Weight : 0.023kg
- Q'ty/Box : 200pcs

- A-001: 2pcs
- M0625/N06W-55: 1set
- Weight : 0.055kg
- Q'ty/Box : 100set

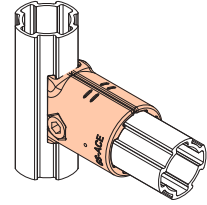
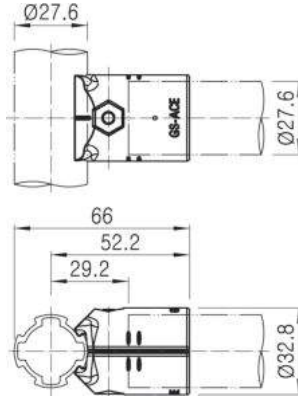

A-001C

Single Tee Joint (For Round Pipe)



<AA-001C>

- Weight : 0.025kg
- Q'ty/Box : 200pcs

- A-001C: 2pcs
- M0625/N06W-55: 1set
- Weight : 0.060kg
- Q'ty/Box : 100set

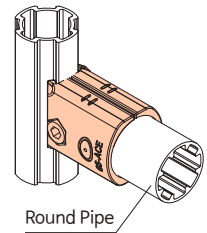
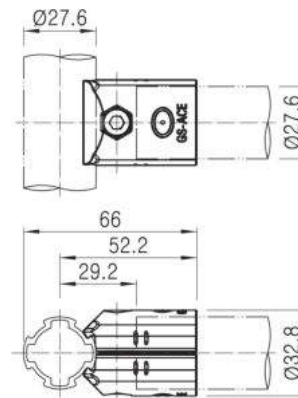

A-003

Outer Elbow Joint



<AA-002>

- Weight : 0.068kg
- Q'ty/Box : 60pcs

- A-003: 1pcs, A-001: 2pcs
- M0625/N06W-55: 2set
- Weight : 0.123kg
- Q'ty/Box : 30set

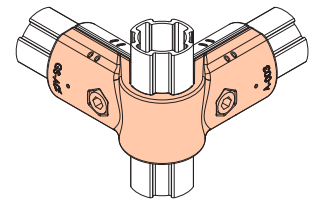
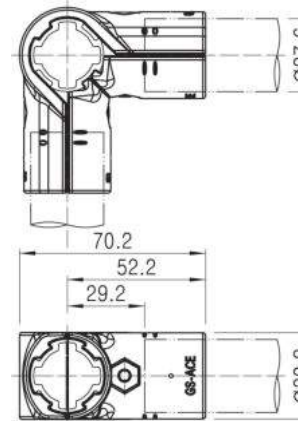

A-004

Straight Joint



<AA-004>

- Weight : 0.064kg
- Q'ty/Box : 80pcs

- A-004: 2pcs
- M0625/N06W-55: 2set
- Weight : 0.126kg
- Q'ty/Box : 40set

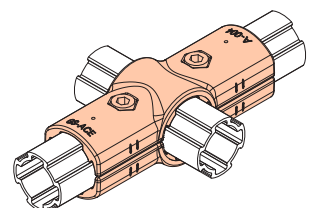
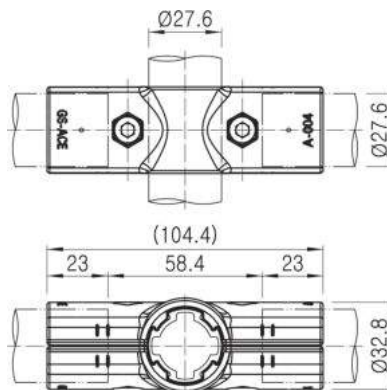

Ø28 AL RACKING SYSTEM

◆ Outer Joints (Patented)

B-007A

Swivel Joint (Rotation, Angle Adjust & Fix)

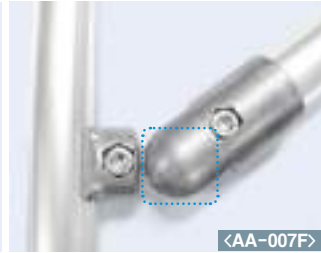

- Weight : 0.017kg
- Q'ty/Box : 400pcs

- A-007B: 2pcs, B-007A: 2pcs
- M0625/N06W-55: 1set,
- M0620/N06W-55: 1set
- Weight : 0.112kg
- Q'ty/Box : 50set

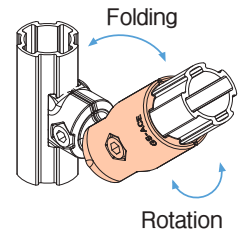
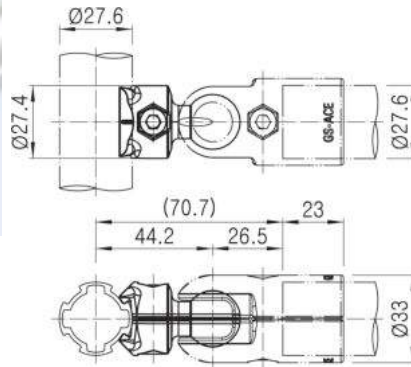

A-007B

Swivel Joint (Angle Adjust & Fix)

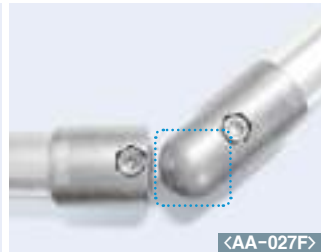

- Weight : 0.031kg
- Q'ty/Box : 200pcs

- A-007B: 2pcs, A-007C: 2pcs
- M0625/N06W-55: 2set
- Weight : 0.134kg
- Q'ty/Box : 50set

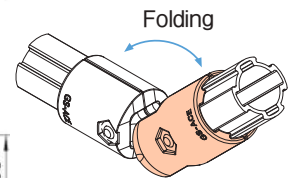
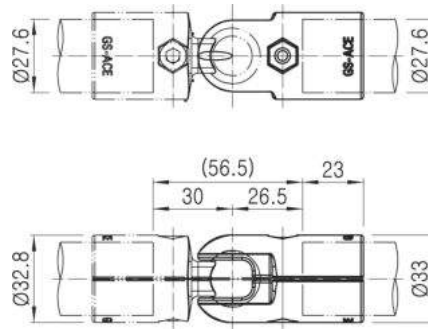

A-007C

Swivel Joint (Angle Adjustable)



- Weight : 0.027kg
- Q'ty/Box : 200pcs

- A-007C: 2pcs, A-007D: 2pcs
- M0625/N06W-55 : 2set
- Weight : 0.133kg
- Q'ty/Box : 50set

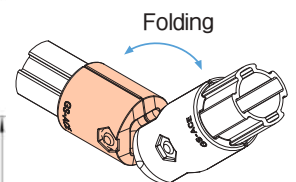
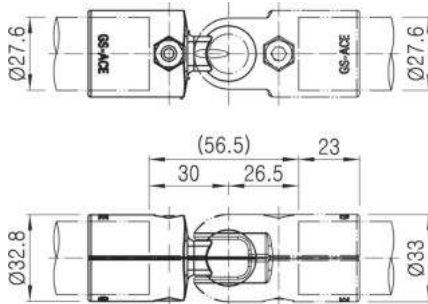

A-007D

Swivel Joint (Rotation, Angle Adjustable)



- Weight : 0.031kg
- Q'ty/Box : 200pcs

- A-007D: 2pcs B-007A: 2pcs
- M0620/N06W-55: 1set
- M0625/N06W-55: 1set
- Weight : 0.112kg/m
- Q'ty/Box : 50set

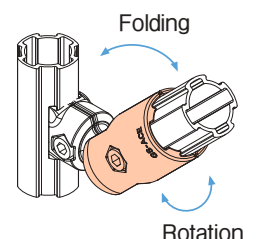
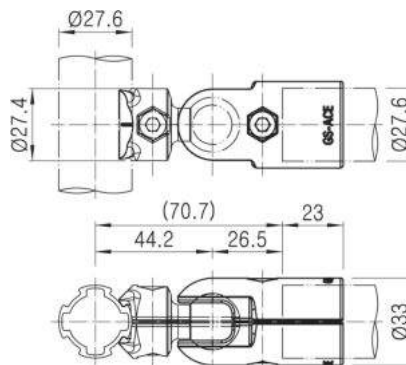

Ø28 AL RACKING SYSTEM

◆ Outer Joints (Patented)

A-009

Double Tee Joint



- Weight : 0.050kg
- Q'ty/Box : 100pcs
- A-009: 2pcs
- M0625/N06W-55: 1set
- Weight : 0.109kg
- Q'ty/Box : 50set

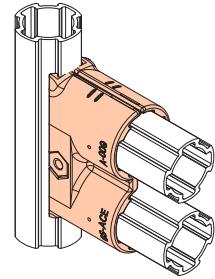
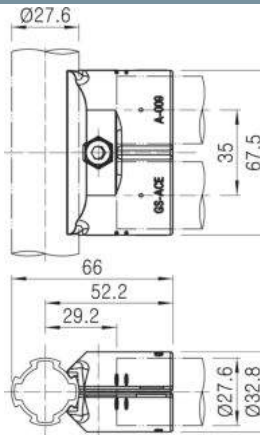

A-013L, A-013R

45° Joint



- Weight : 0.023kg
- Q'ty/Box : 200pcs
- A-013L: 1pcs, A-013R: 1pcs
- M0625/N06W-55: 1set
- Weight : 0.054kg
- Q'ty/Box : 100set

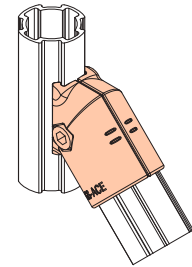
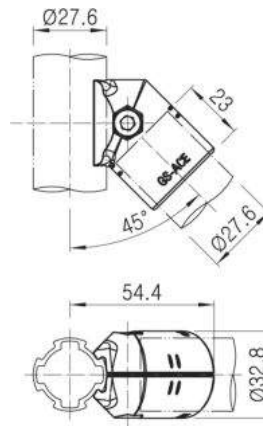

A-021

Single Tee Joint



- Weight : 0.033kg
- Q'ty/Box : 120pcs
- A-021 : 2pcs
- M0625/N06W-55 : 1set
- Weight : 0.074kg
- Q'ty/Box : 60set

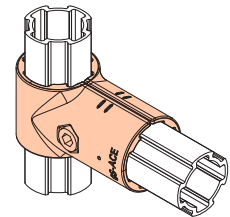
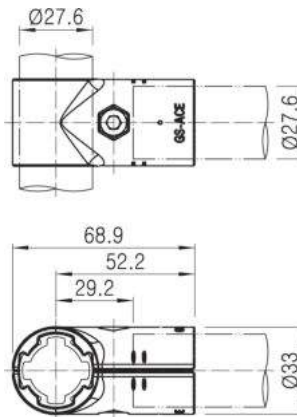

A-023

Stop Joint



- Weight : 0.017kg
- Q'ty/Box : 300pcs
- A-023: 2pcs
- M0620/N06W-55: 1set
- Weight : 0.037kg
- Q'ty/Box : 150set

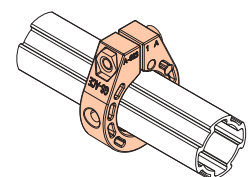
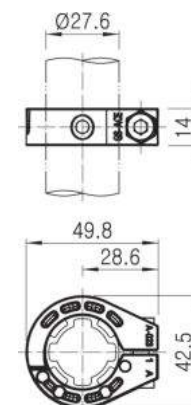

Ø28 AL RACKING SYSTEM

◆ Outer Joints (Patented)

A-028

Parallel Joint



- Weight : 0.026kg
- Q'ty/Box : 150pcs

- A-028: 2pcs
- M0625/N06W-55: 1set
- Weight : 0.060kg
- Q'ty/Box : 75set

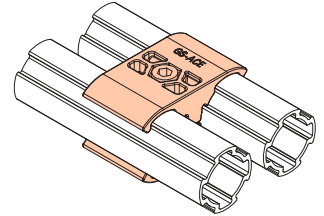
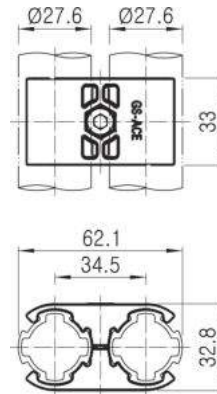

A-090

90 ° Elbow Joint



- Weight : 0.050kg
- Q'ty/Box : 80pcs

- A-090: 2pcs
- M0625/N06W-55: 1set
- Weight : 0.110kg
- Q'ty/Box : 40set

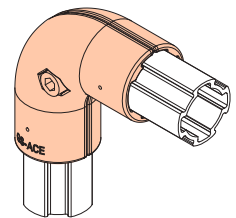
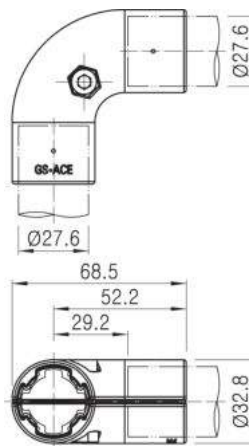

A-101

Single Tee Joint

Design Patent



- Weight : 0.026kg
- Q'ty/Box : 200pcs

- A-101 : 2pcs
- M0625/M06W-55 : 1set
- Weight : 0.062kg
- Q'ty/Box : 100set

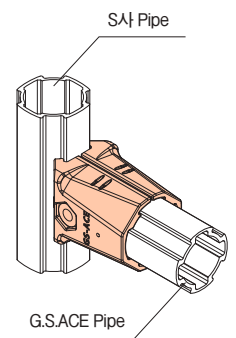
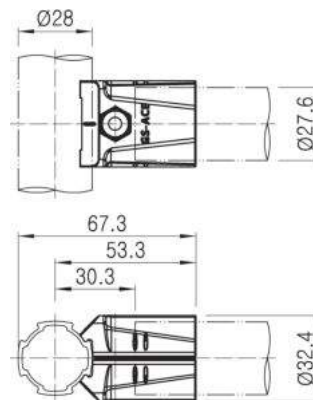

A-201

Single Tee Joint

Design Patent



- Weight : 0.026kg
- Q'ty/Box : 200pcs

- A-201 : 2pcs
- M0625/N06W-55 : 1set
- Weight : 0.060kg
- Q'ty/Box : 100set

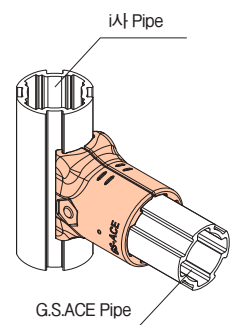
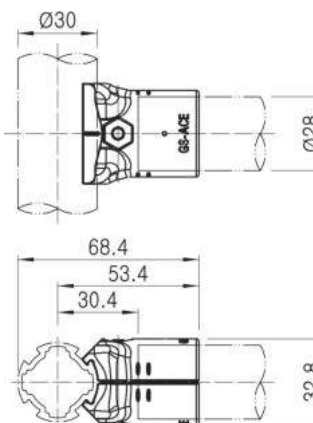

Ø28 AL RACKING SYSTEM

◆ Inner Joints (Patented)

B-001 Single Tee Joint



- Weight : 0.018kg
- Q'ty/Box : 300pcs
- B-001: 2pcs
- M0620/N06W-55: 1set
- Weight : 0.044kg
- Q'ty/Box : 150set

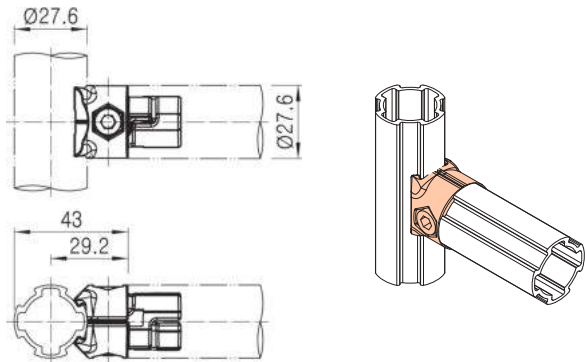

B-001H Single Tee Joint (Heavy Duty)



- Weight : 0.020kg
- Q'ty/Box : 240pcs
- B-001H: 2pcs
- M0620/N06-55 : 1set
- Weight : 0.048kg
- Q'ty/Box : 120set

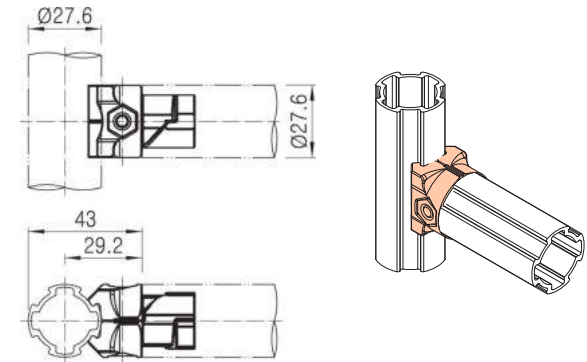

B-001C Single Tee Joint (Pipe Angle Adjustable)



- Weight : 0.018kg
- Q'ty/Box : 300pcs
- B-001C: 2pcs
- M0620/N06W-55 : 1set
- Weight : 0.044kg
- Q'ty/Box : 150set

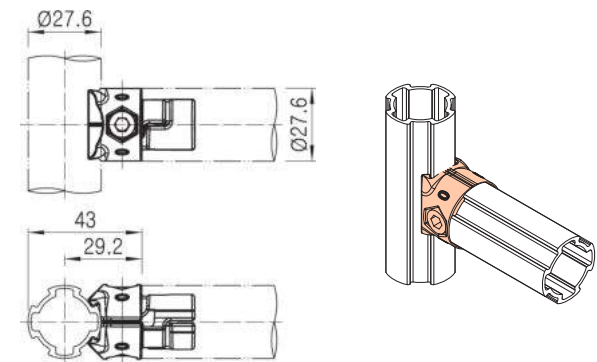

B-006 90° Offset Joint



- Weight : 0.012kg
- Q'ty/Box : 400pcs
- B-006: 2pcs
- M0625/N06W-55: 1set
- Weight : 0.036kg
- Q'ty/Box : 200set

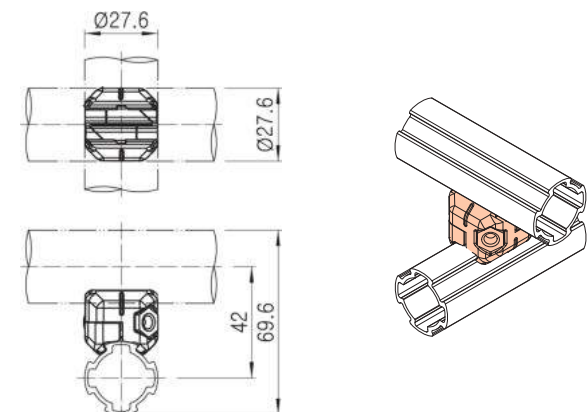

Ø28 AL RACKING SYSTEM

◆ Inner Joints (Patented)

B-007A

Swivel Joint (Rotation, Angle Adjust & Fix)

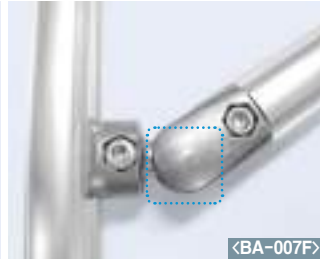

- Weight : 0.017kg
- Q'ty/Box : 400pcs

- B-007A: 2pcs, B-007B: 2pcs
- M0620/N06W-55: 2set
- Weight : 0.099kg
- Q'ty/Box : 80set

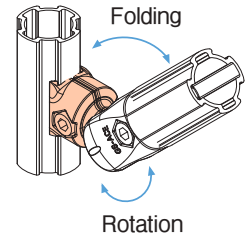
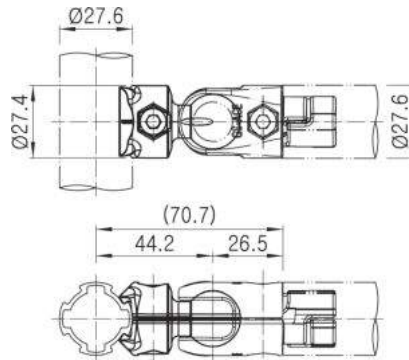

B-007B

Swivel Joint (Angle Adjust & Fix)

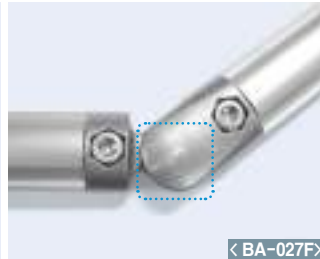

- Weight : 0.025kg
- Q'ty/Box : 250pcs

- B-007B: 2pcs, B-007C: 2pcs
- M0620/N06W-55: 2set
- Weight : 0.112kg
- Q'ty/Box : 80set

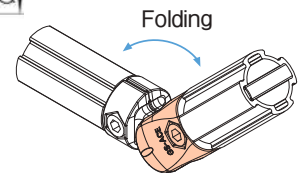
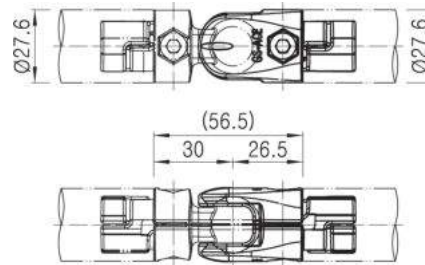

B-007C

Swivel Joint (Angle Adjustable)



- Weight : 0.023kg
- Q'ty/Box : 250pcs

- B-007C: 2pcs, B-007D: 2pcs
- M0620/N06W-55: 2set
- Weight : 0.111kg
- Q'ty/Box : 80set

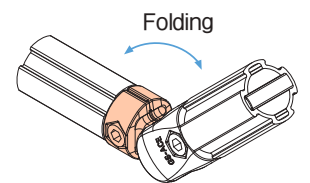
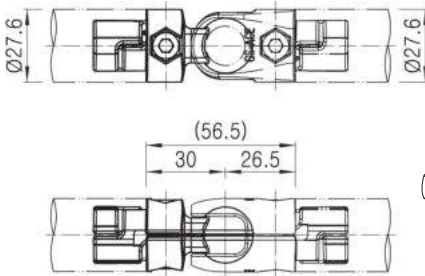

B-007D

Swivel Joint (Rotation, Angle Adjustable)



- Weight : 0.025kg
- Q'ty/Box : 250pcs

- B-007A: 2pcs, B-007D: 2pcs
- M0620/N06W-55: 2set
- Weight : 0.098kg
- Q'ty/Box : 80set

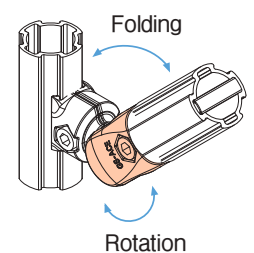
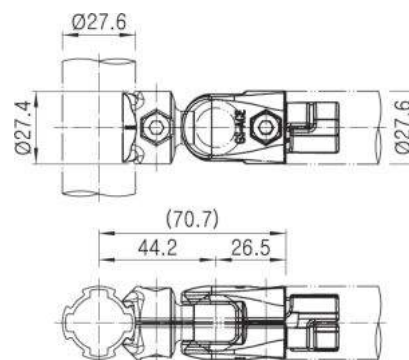

Ø28 AL RACKING SYSTEM

◆ Inner Joints (Patented)

B-008

Parallel Joint



<BA-008>

- Weight : 0.013kg
- Q'ty/Box : 400pcs

- B-008: 2pcs
- M0620/N06W-55: 1set
- Weight : 0.032kg
- Q'ty/Box : 200set

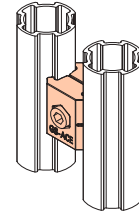
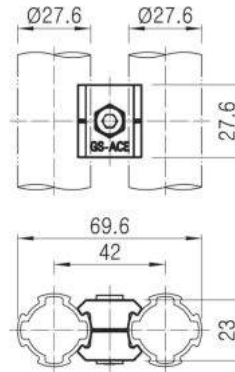

B-011

Parallel Joint



<BA-011>

- Weight : 0.030kg
- Q'ty/Box : 200pcs

- B-011: 2pcs
- M0620/N06W-55: 2set
- Weight : 0.075kg
- Q'ty/Box : 100set

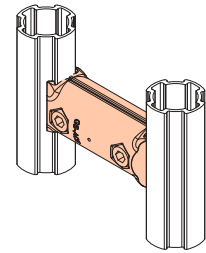
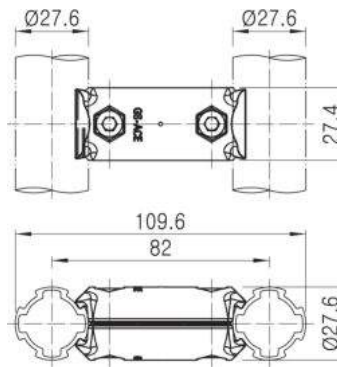

B-013L, B-013R

45° Joint



<BA-013>

- Weight : 0.018kg
- Q'ty/Box : 300pcs

- B-013L: 1pcs, B-013R: 1pcs
- M0620/N06W-55: 1set
- Weight : 0.043kg
- Q'ty/Box : 150set

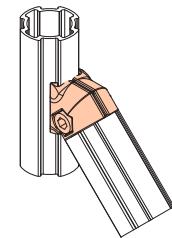
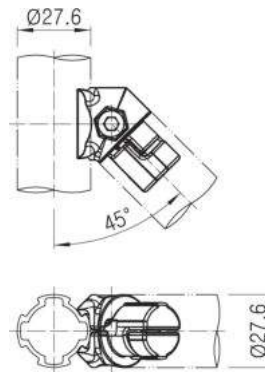

B-017A-08

Panel Joint



- Weight : 0.030kg
- Q'ty/Box : 200pcs

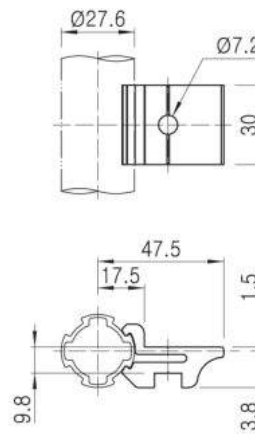

Flat Headed Bolt
(5T : CM0620)

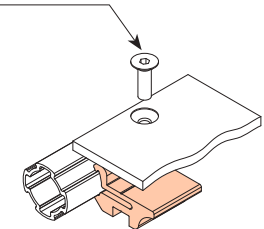

N06W-55

Ø28 AL RACKING SYSTEM

◆ Inner Joints (Patented)



B-044B

Straight Connector Joint



<BA-044B>

- Weight : 0.024kg
- Q'ty/Box : 200pcs

- B-044B : 2pcs
- M0620/N06W-55: 1set
- Weight : 0.058kg
- Q'ty/Box : 100set

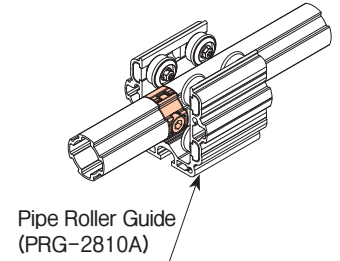
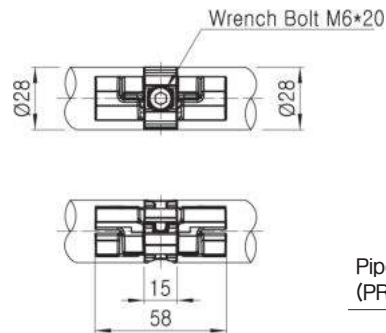

Pipe Roller Guide (PRG-2810A)

B-045

Corner Joint



<BA-045>

- Weight : 0.048kg
- Q'ty/Box : 100pcs

- B-045: 2pcs
- M0620/N06W-55: 2set
- Weight : 0.114kg
- Q'ty/Box : 50set

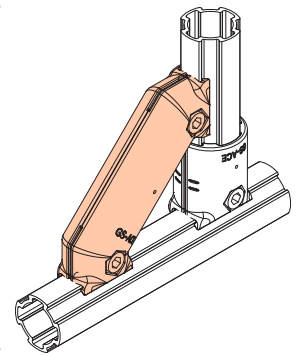
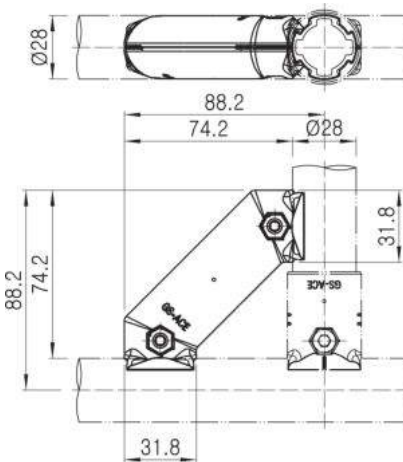

B-090

90° Elbow Joint



<BA-090>

- Weight : 0.039kg
- Q'ty/Box : 120pcs

- B-090: 2pcs
- M0620/N06W-55: 1set
- Weight : 0.086kg
- Q'ty/Box : 60set

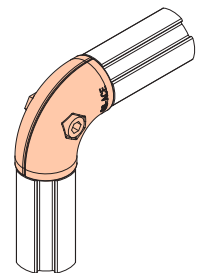
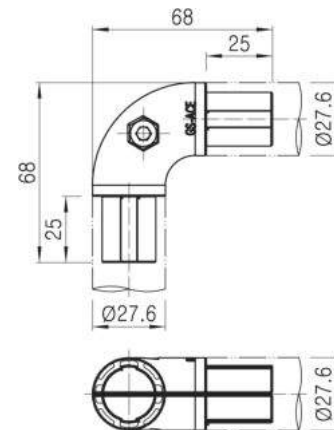

B-091

90° Elbow Joint (for 8T Panel)



<BA-091>

- Weight : 0.039kg
- Q'ty/Box : 120pcs

- B-091 : 2pcs
- M0620/N06W-55 : 1set
- Weight : 0.086kg
- Q'ty/Box : 60set

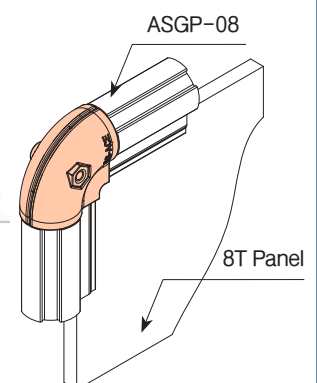
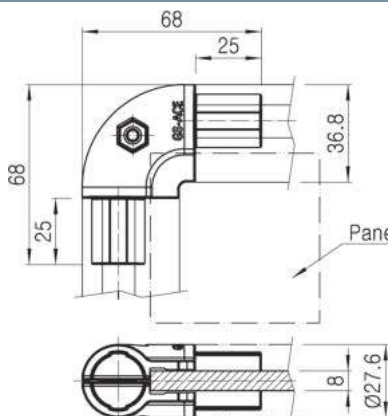

ASGP-08

Panel

8T Panel

Ø28 AL RACKING SYSTEM

◆ Inner Joints (Patented)

B-101 Single Tee Joint

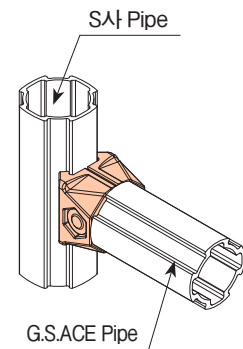
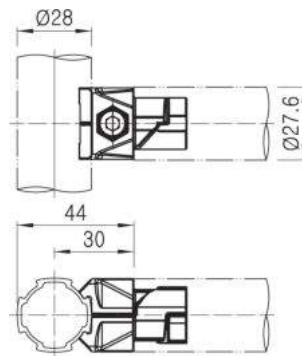

- Weight : 0.020kg
- Q'ty/Box : 200pcs

- B-101 : 2pcs
- M0620/N06W-55 : 1set
- Weight : 0.048kg
- Q'ty/Box : 100ea

B-145 Corner Joint

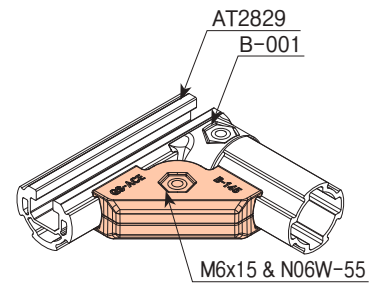
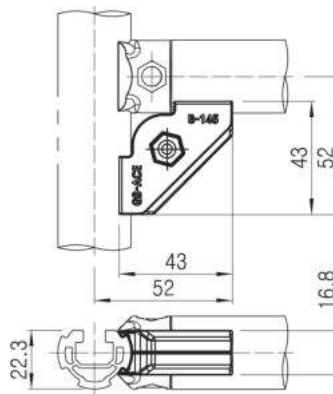

- Weight : 0.020kg
- Q'ty/Box : 400pcs

- B-145 : 2pcs
- M6x10/N06W-55 : 1set
- Weight : 0.047kg
- Q'ty/Box : 200set

BA-206 Crossover Joint (Angle Adjustable)



- B-206A: 1pcs, • M0620/N06W-55: 2set • Weight : 0.117kg
- B-206B: 1pcs, • M0625: 1pcs • Q'ty/Box : 60set
- B-206C: 1pcs,
- B-206D: 1pcs

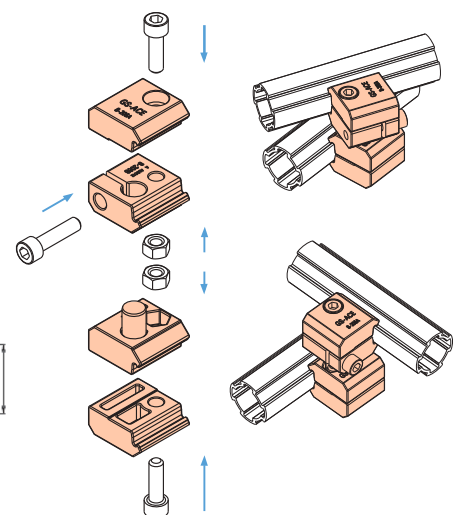
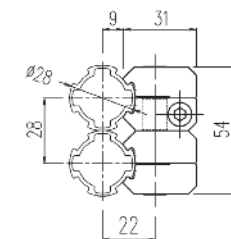

- Weight : 0.020kg
- Q'ty/Box : 240pcs

- Weight : 0.020kg
- Q'ty/Box : 240pcs

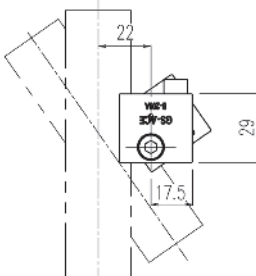

- Weight : 0.035kg
- Q'ty/Box : 240pcs

- Weight : 0.020kg
- Q'ty/Box : 240pcs

Ø28 AL RACKING SYSTEM

Φ 28 ALUMINUM ACCESSORIES

A28-A301

AL Gas Spring Bracket

A28-301A



- Weight : 0.027kg
- Q'ty/Box : 160pcs

A28-301B



- Weight : 0.019kg
- Q'ty/Box : 160pcs



A28-A301

- A28-301 A/B : 1set
- M0625/N06W-55 : 1set
- Weight : 0.056kg
- Q'ty/Box : 80set

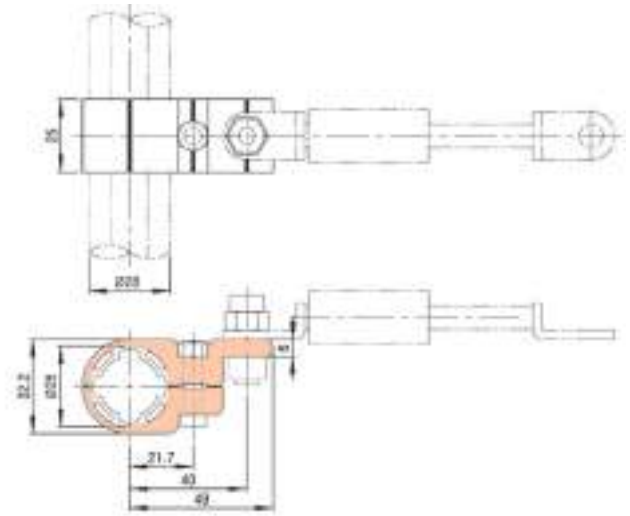

A28-N302

AL Board Support (Outside)



- Weight : 0.012kg
- Q'ty/Box : 250pcs

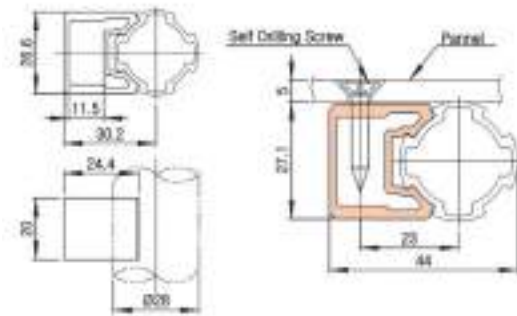

A28-N303

AL Board Support (Inside)



- Weight : 0.005kg
- Q'ty/Box : 800pcs

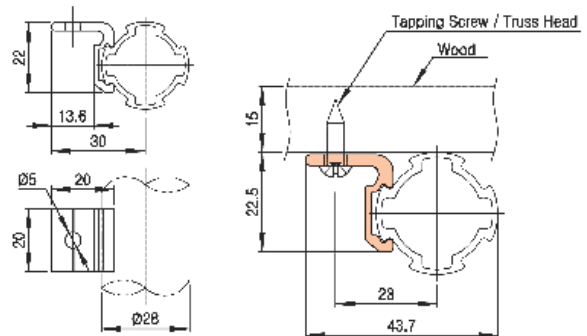

ABS-620

Board Support



- Weight : 0.020kg
- Q'ty/Box : 300pcs



- ABS-600SA Standard Length : 4MT

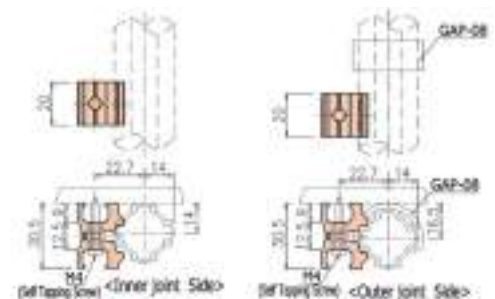

Ø28 AL RACKING SYSTEM

ACY-N301

Plastic Cable Holder

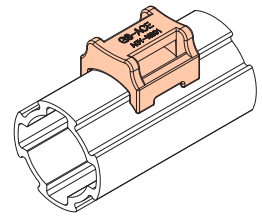
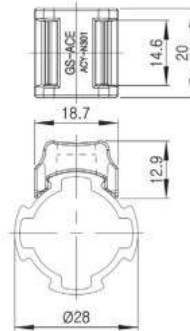

- Weight : 0.002kg
- Q'ty/Box : 3000pcs

ACY-303A

Roller Track Guide Bracket

Patented

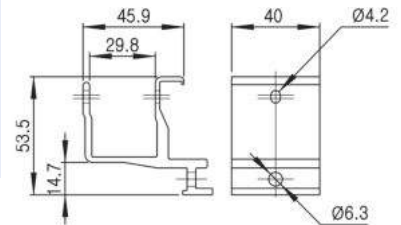

- Weight : 0.055kg
- Q'ty/Box : 40pcs
- ACY-303A : 2pcs
- DR-40R : 2pcs
- M6*30/N06W-55 : 1set
- M4*40/NN04W : 2set
- ACY-303A : 2pcs
- Roller 40A, B, C, D : 2pcs
- M6*30/N06W-55 : 1set
- M4*40/NN04W : 2set

ACY-303B

Roller Track Guide Bracket

Patented

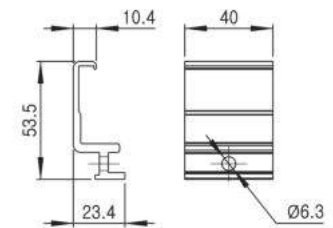

- Weight : 0.029kg
- Q'ty/Box : 80pcs
- ACY-303A, B : 1set
- DR-40R : 1pcs
- M6*30/N06W-55 : 1set
- M4*40/NN04W : 1set
- ACY-303A, B : 1set
- Roller 40A, B, C, D : 1pcs
- M6*30/N06W-55 : 1set
- M4*40/NN04W : 1set

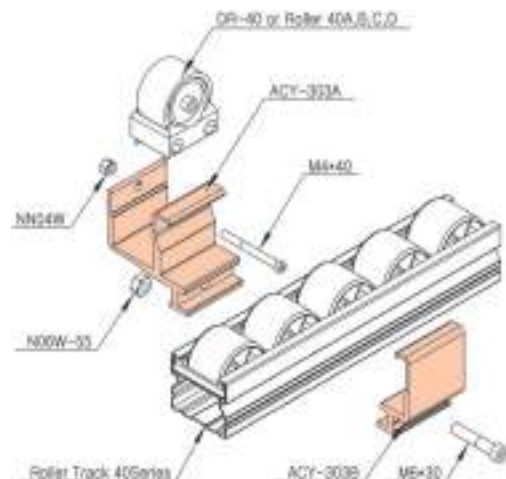
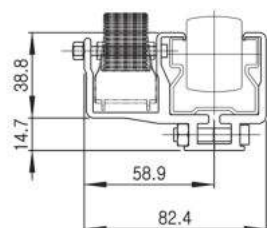
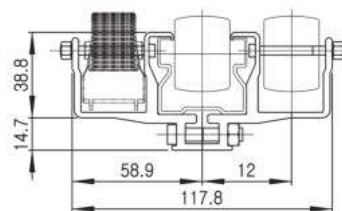

Ø28 AL RACKING SYSTEM

ACY-A306

AL Roller Guide



- Weight : 0.083kg
- Q'ty/Box : 60pcs

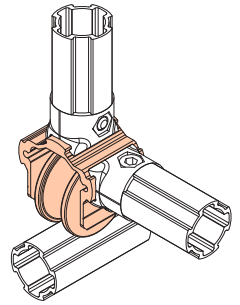
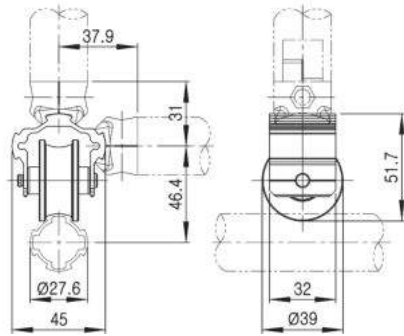

Ø28 AL RACKING SYSTEM

ARU-28A

AL Rotary Unit



- Weight : 0.240kg
- Q'ty/Box : 40pcs

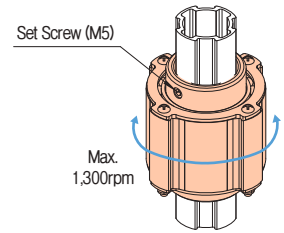
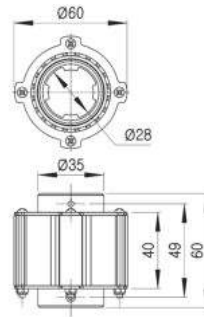

ACA-309A

One Way Clutch



- Weight : 0.320kg
- Q'ty/Bundle : 20pcs

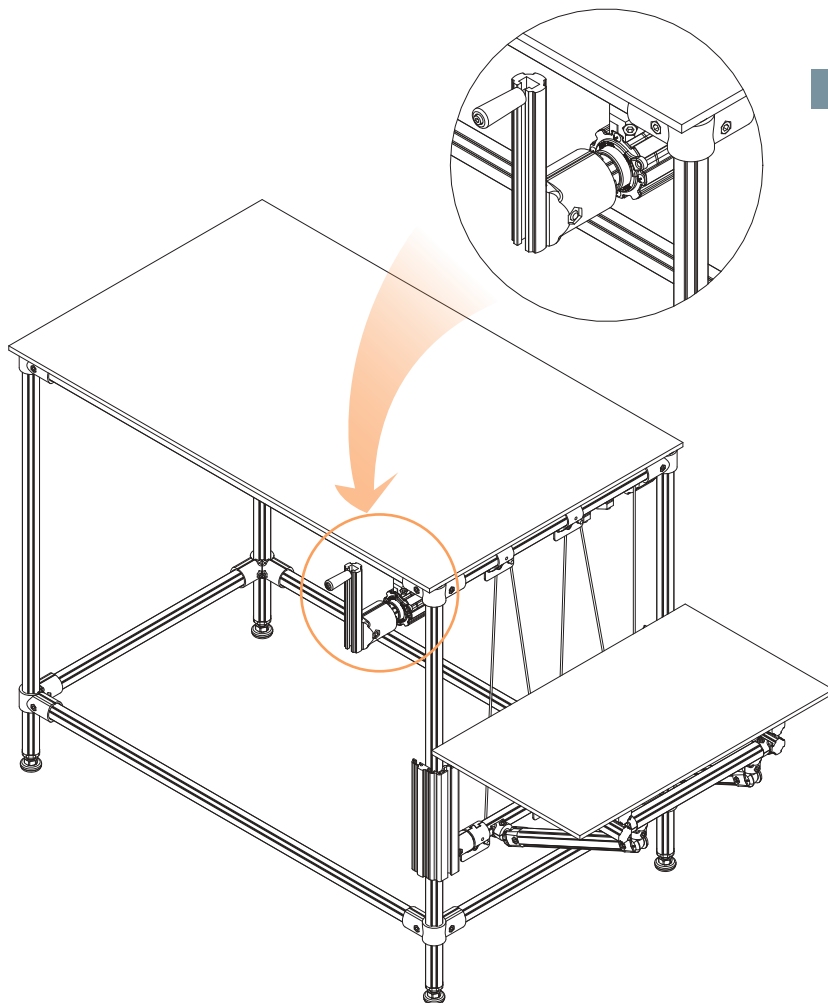
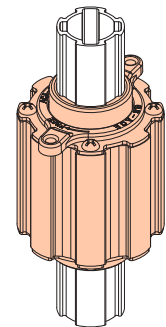
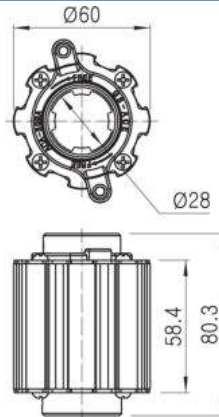

APPLICATIONS OF ONE WAY CLUTCH

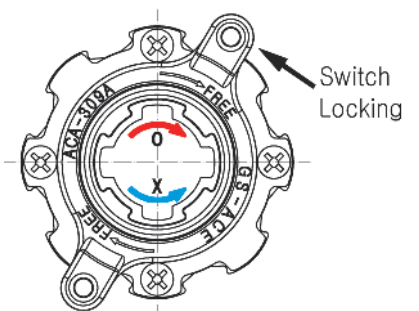

- ※ Switch Locking
Inner Pipe Rotate CW
and Locked CCW

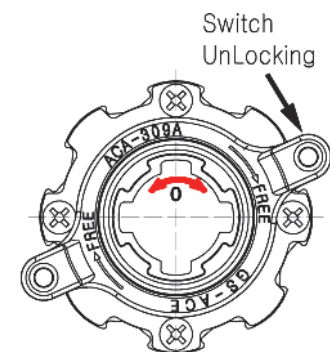

- ※ Switch UnLocking
Inner Pipe Rotate
CW and CCW

Ø28 AL RACKING SYSTEM



ACY-311A

Panel Cover (For Corner)



- Weight : 0.032kg
- Q'ty/Bundle : 90pcs

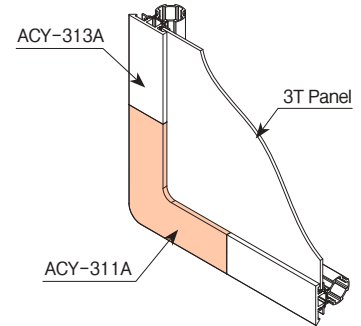
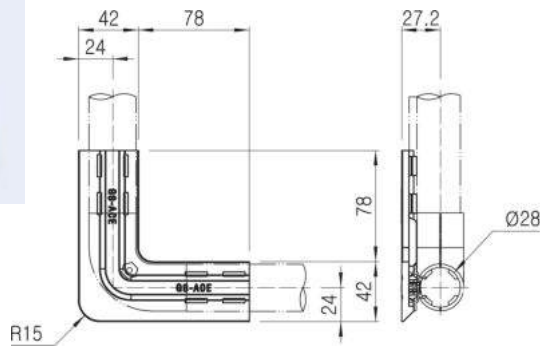

ACY-312A

AL Sheet Guide (For Panel Cover)



- Weight : 0.192kg
- Q'ty/Bundle : 20pcs
- Standard Length : 4MT

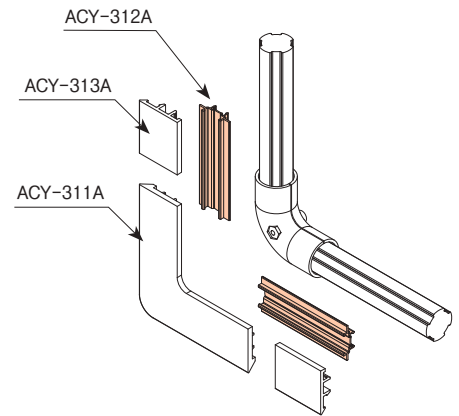
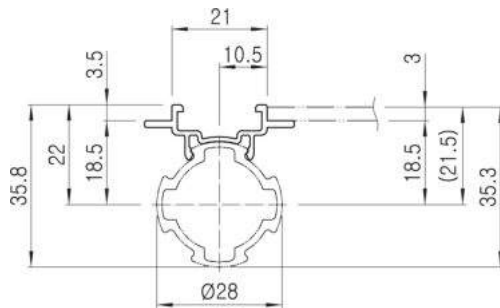

ACY-313A

Panel Cover (For Outer Pipe)



- Weight : 0.151kg
- Q'ty/Box : 30pcs
- Standard Length : 3MT

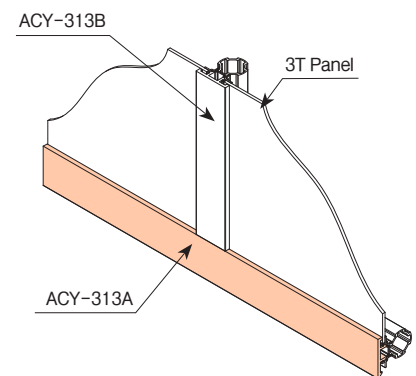
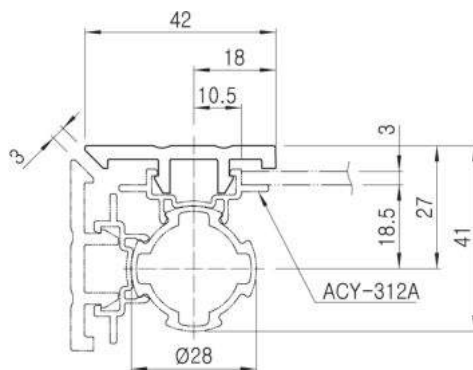

ACY-313B

Panel Cover (For Inner Pipe)



- Weight : 0.136kg
- Q'ty/Box : 30pcs
- Standard Length : 3MT

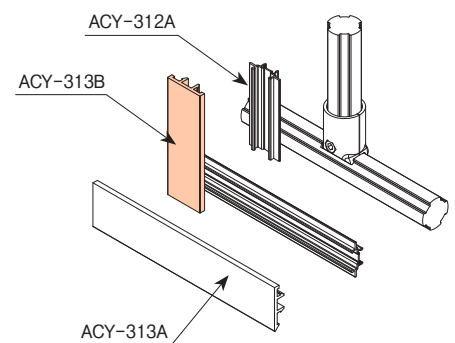
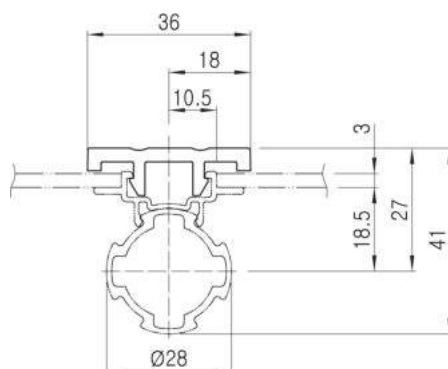

Ø28 AL RACKING SYSTEM

AL RACKING



ACA-315A

Joint Coupling Clamp



- Weight : 0.210kg
- Q'ty/Bundle : 24pcs

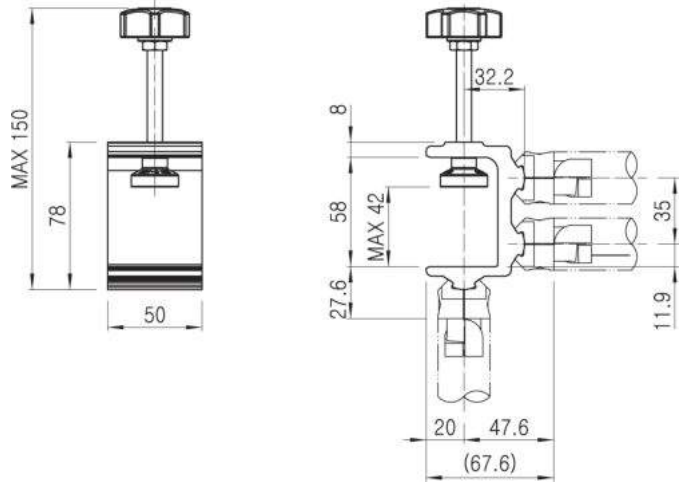

ACY-315C

Plastic Leveling Foot (For M6 Bolt)



- Weight : 0.005kg
- Q'ty/Box : 900pcs

* Wrench Bolt는 별매임

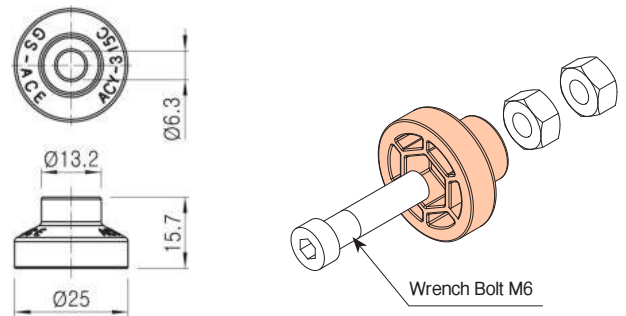

ACY-318A

Pipe Connecting Adapter



- Weight : 0.034kg
- Q'ty/Box : 150pcs

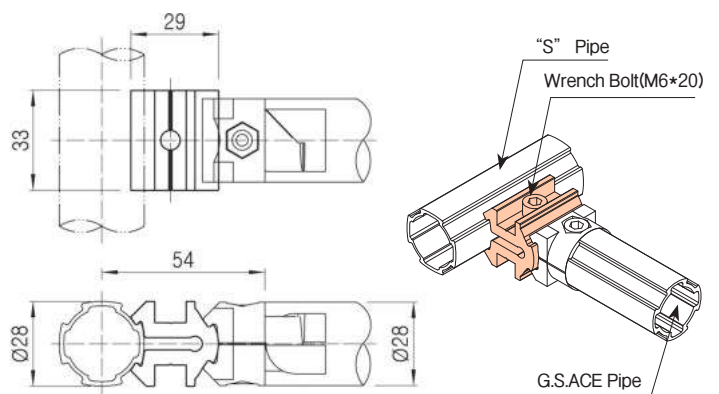

ACY-318B

Pipe Connecting Adapter



- Weight : 0.027kg
- Q'ty/Box : 150pcs

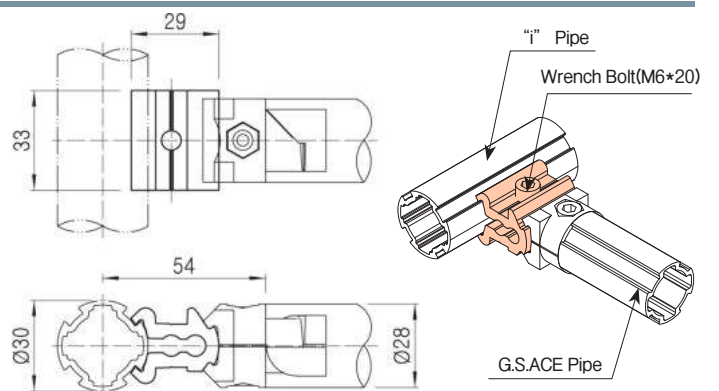

Ø28 AL RACKING SYSTEM



ACA-2060A/80A Link Guide Unit

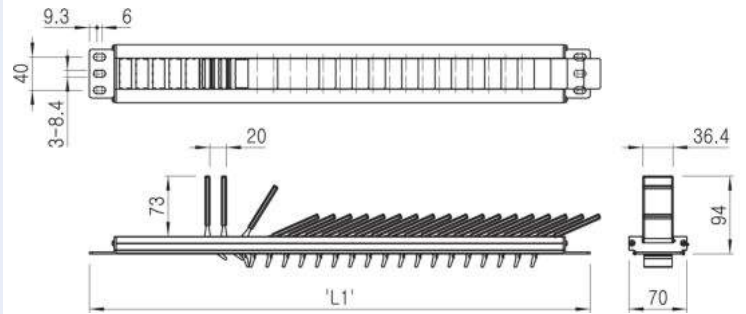

- Weight : ACA-2060A 1.945kg
ACA-2080A 2.690kg

NO	ITEM NO	" L1 "	Pitch
1	ACA-2060A	605mm	20mm
2	ACA-2080A	800mm	

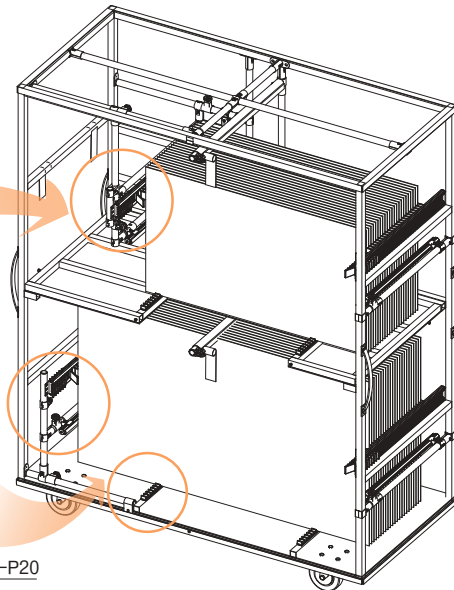
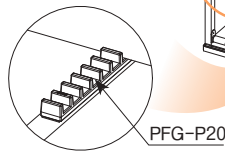
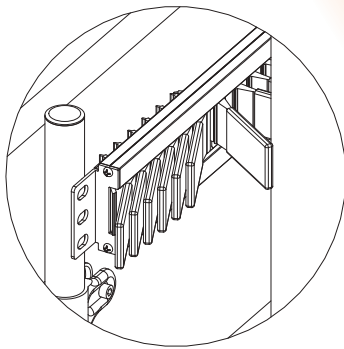

ACA-4060A/80A Link Guide Unit

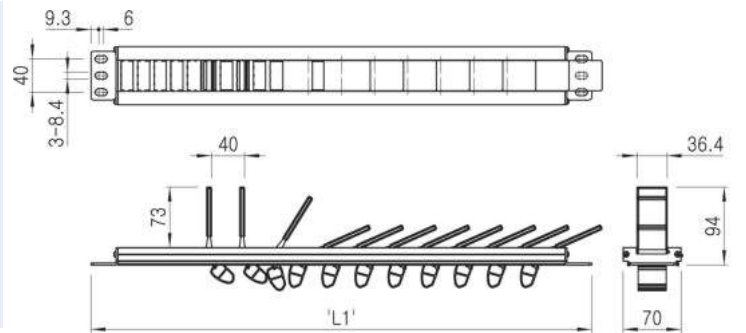

- Weight : ACA-4060A 1.376kg
ACA-4080A 1.898kg

NO	ITEM NO	" L1 "	Pitch
1	ACA-4060A	605mm	40mm
2	ACA-4080A	800mm	

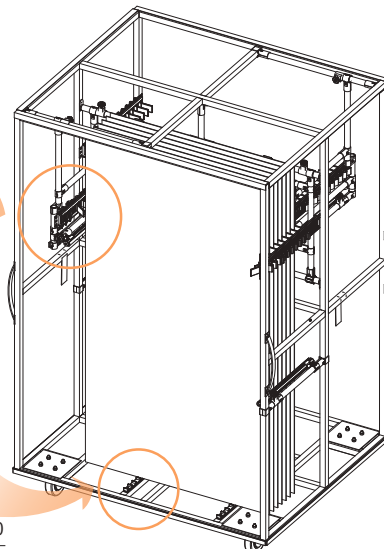
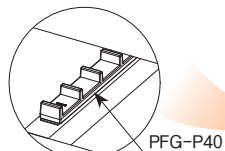
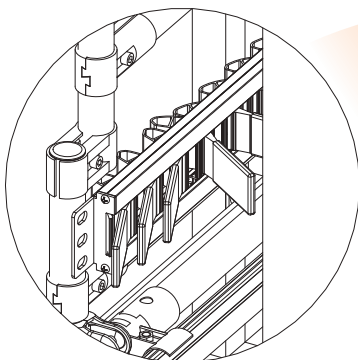

Ø28 AL RACKING SYSTEM

ACB-B28A/B AL Corner Base



- Weight : 0.208kg
- Q'ty/Box : 24pcs

- ACB-B28A/B : 1set
- A-003 : 1EA
- M0625/N06W-55 : 2set
- Weight : 0.296kg
- Q'ty/Box : 24set

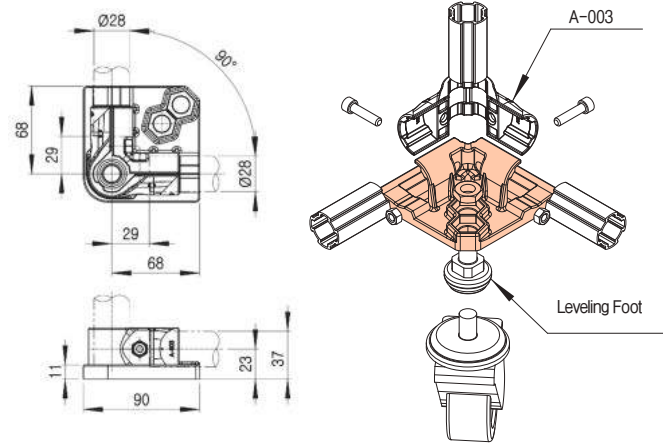

ACD-B Cable Duct



- Weight : 0.177kg/m
- Q'ty/Bundle : 12pcs

- Standard Length : 4MT

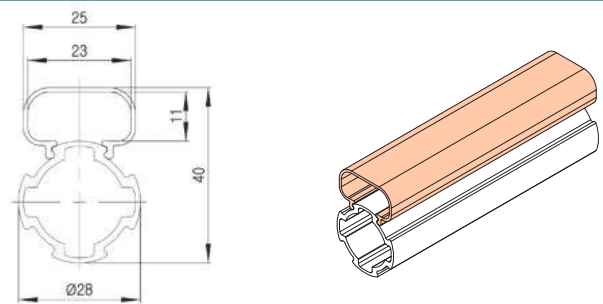

ACM-500 AL Caster Mount



- Weight : 0.054kg
- Q'ty/Box : 100pcs

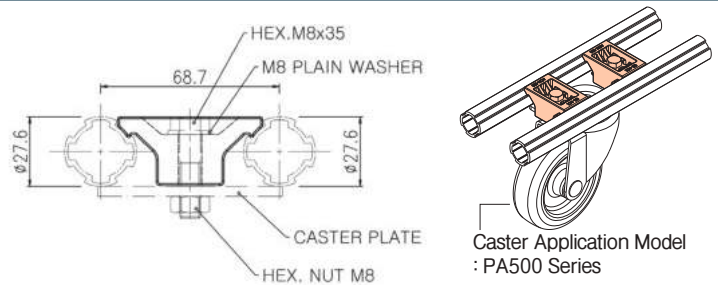

ACM-500-S AL Caster Mount (For Aid)



- Weight : 0.024kg
- Q'ty/Box : 200pcs

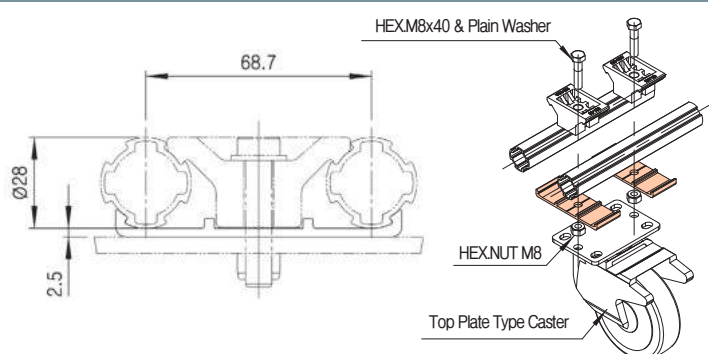

Ø28 AL RACKING SYSTEM

ACPA-H6026A AL Connector Piece

ACP-H6026A-L



ACP-H6026A-R



<ACPA-H6026A>

- Weight : 0.007kg
- Q'ty/Box : 800pcs
- ACP-H6026A-L/R : 1set
- M0630 : 2pcs • Q'ty/Box : 300set

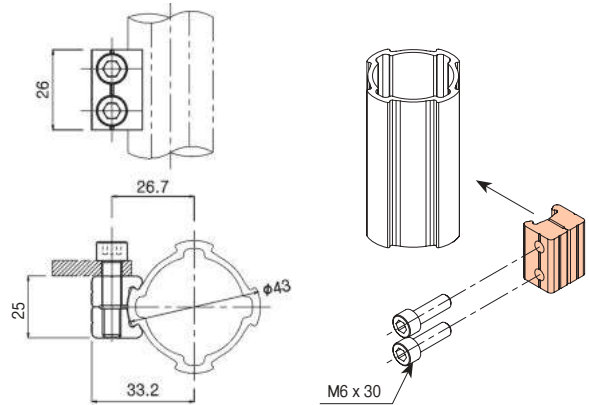

ACPA-V6026A AL Connector Piece

ACP-V6026A-L



ACP-V6026A-R



<ACPA-V6026A>

- Weight : 0.007kg
- Q'ty/Box : 800pcs
- ACP-V6026A-L/R : 1set
- M0625 : 2pcs • Q'ty/Box : 300set

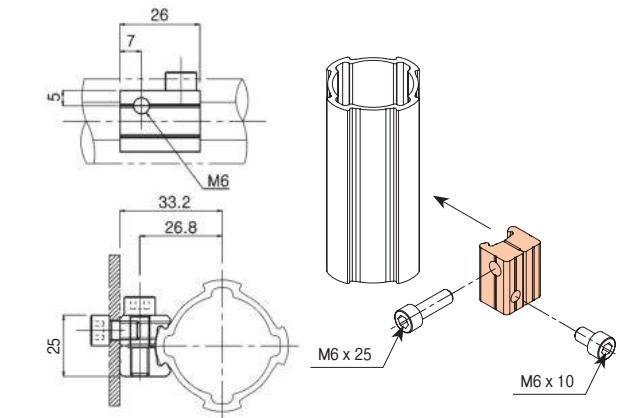

SPS-0635 Spring Shaft



<ACPS-H6026A>

- Weight : 0.008kg
- Q'ty/Box : 4000pcs
- ACP-H6026A-L/R : 1set
- SPS-0635 : 1pcs
- /N06-55 : 1set
- Weight : 0.034kg
- Q'ty/Box : 300set

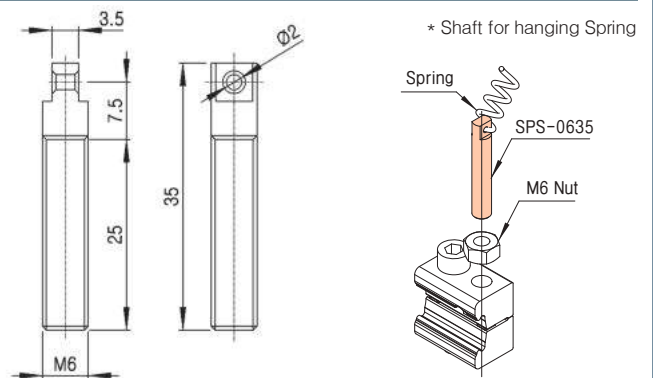

ADR-05 Door Rail



- Weight : 0.166kg/m
- Q'ty/Bundle : 20pcs
- Standard Length : 4MT

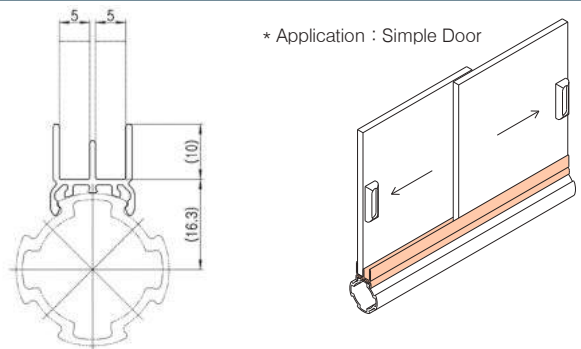

Ø28 AL RACKING SYSTEM

ACY-06A/B Mount Bracket (General Use)

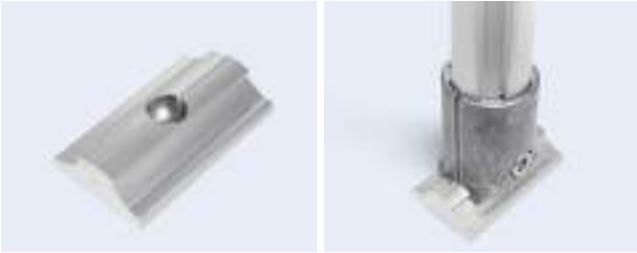

- Weight : 0.027kg
- Q'ty/Box : 240pcs

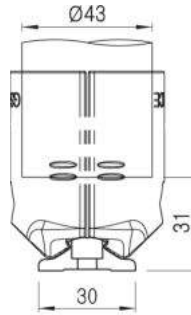

Item No.	"L"
ACY-06A	52mm
ACY-06B	33mm

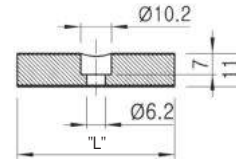

** For assembling Joint to Flat Surface

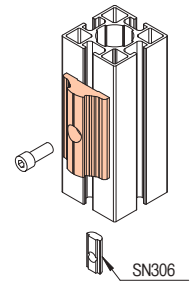

ACY-07A Slot Adaptor (for 40x40 AL Profile)



- Weight : 0.017kg
- Q'ty/Box : 300pcs

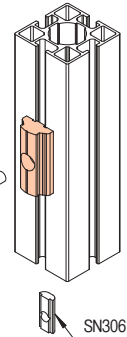
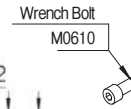
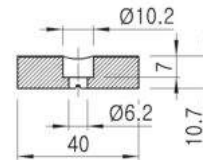
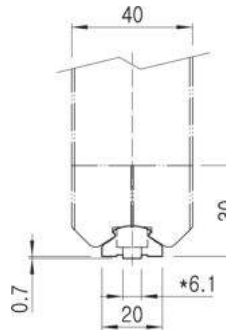

ACY-08A Slot Adaptor (for 45x45 AL Profile)



- Weight : 0.019kg
- Q'ty/Box : 300pcs

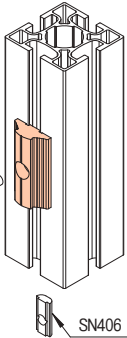
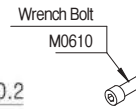
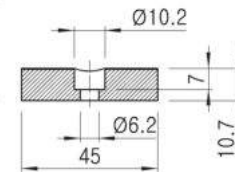
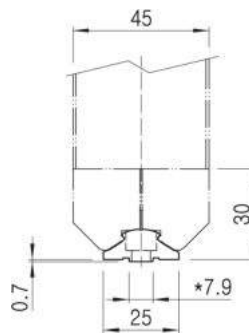

ACY-09A Slot Adaptor (for 45x45 AL Profile)

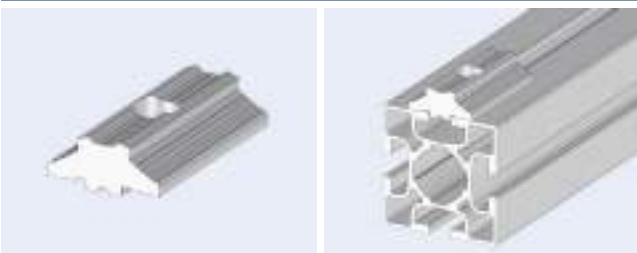

- Weight : 0.019kg
- Q'ty/Box : 300pcs

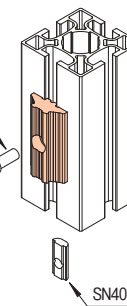
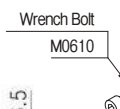
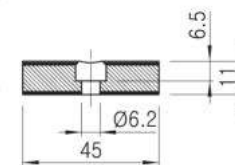
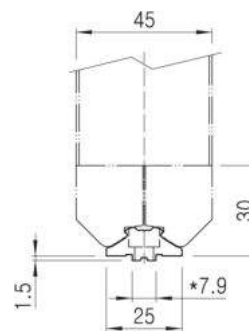

Ø28 AL RACKING SYSTEM

ADT-5H

Slot Adaptor (for T-Slot Pipe)



- Weight : 0.004kg
- Q'ty/Box : 1000pcs

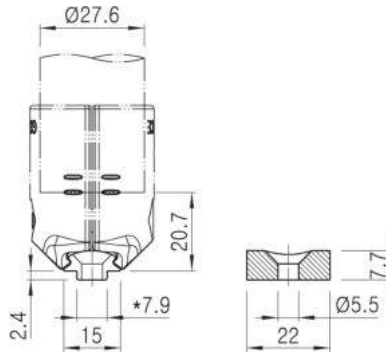

* Reinforce Holding Force between AT2829 & A-001

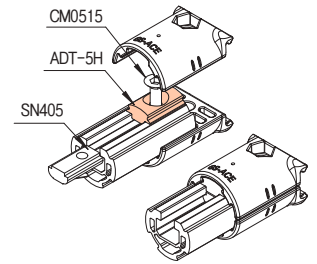

ADT-06/08

Slot Adaptor (for T-Slot Pipe)



- Weight : 0.004kg
- Q'ty/Box : 1,000pcs

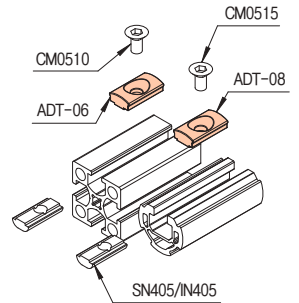
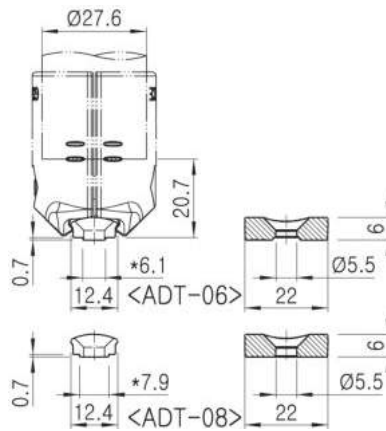

ACY-N307

Slot Adaptor (for T-Slot Pipe)



- Weight : 0.010kg
- Q'ty/Box : 600pcs

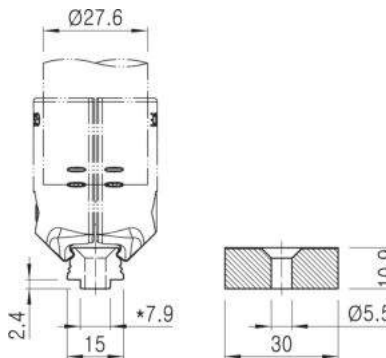

* Attach various Components using Flat Surface

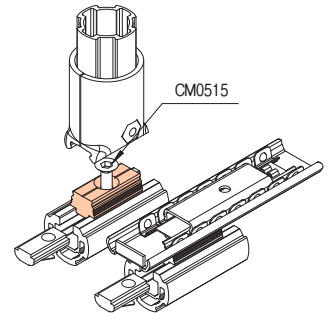

<Table for attachable Pipe/Profile>

Part No.	Aluminum Pipe		Aluminum Profile		Part No.	Aluminum Pipe		Aluminum Profile	
	AT2829	40x40	45x45			AT2829	40x40	45x45	
ACY-06A	△	△	△		ADT-5H	○			○
ACY-06B	△	△	△		ADT-06		○		
ACY-07A				○	ADT-08	○			○
ACY-08A					ACY-N307	○			○
ACY-09A									

Ø28 AL RACKING SYSTEM

ACA-319A

Hinge Unit



- Weight : 0.083kg
- Q'ty/Box : 60pcs

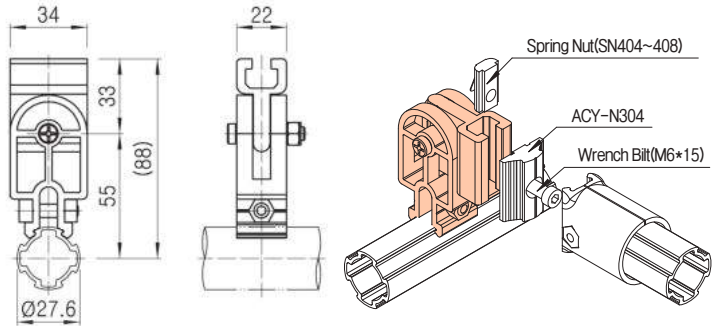

AFU-28A/C/S

AL Folding Unit



- Weight : 0.081kg

- Weight : 0.081kg
- Q'ty/Box : 80pcs

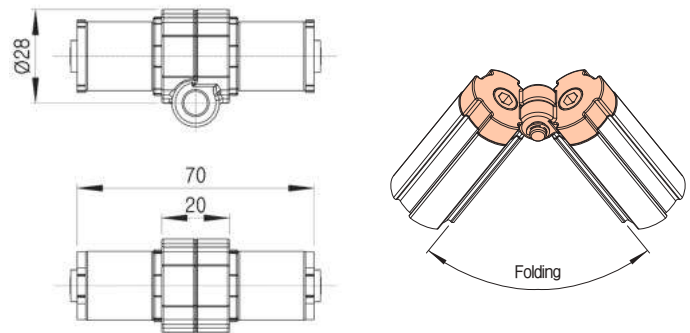

<Table for suitable Pipe>

PART NO.	Aluminum Pipe			Coated Pipe						STS Pipe			Rubber Color
	1.2T	2.0T	2.9T	0.5T	0.7T	0.9T	1.0T	1.4T	2.0T	0.7T	0.9T	1.2T	
AFU-28A	O	O	O	X	X	X	X	O	O	X	X	X	Yellow
AFU-28C	X	X	X	O	O	O	O	X	X	X	X	X	Black
AFU-28S	X	X	X	X	X	X	X	X	X	O	O	O	Gray

Ø28 AL RACKING SYSTEM

AH-540 Rotatable AL Sleeve (Short Type)

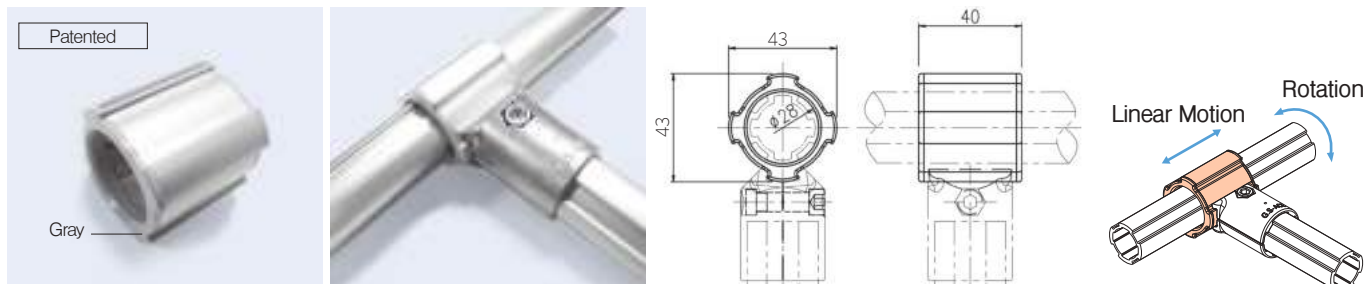

- Weight : 0.034kg
- Q'ty/Box : 100pcs

AH-555 Rotatable AL Sleeve (Long Type)

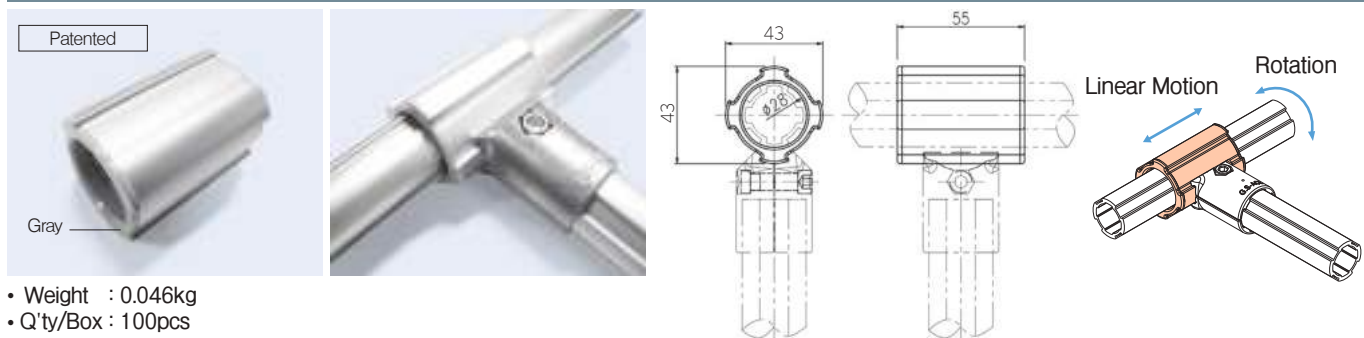

- Weight : 0.046kg
- Q'ty/Box : 100pcs

AH-640 AL Sleeve (Short Type)

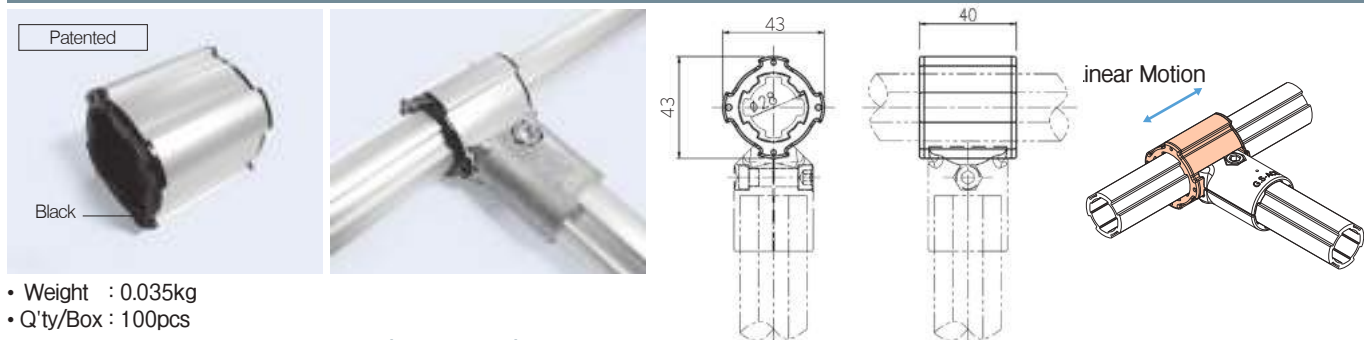

- Weight : 0.035kg
- Q'ty/Box : 100pcs

AH-655 AL Sleeve (Long Type)

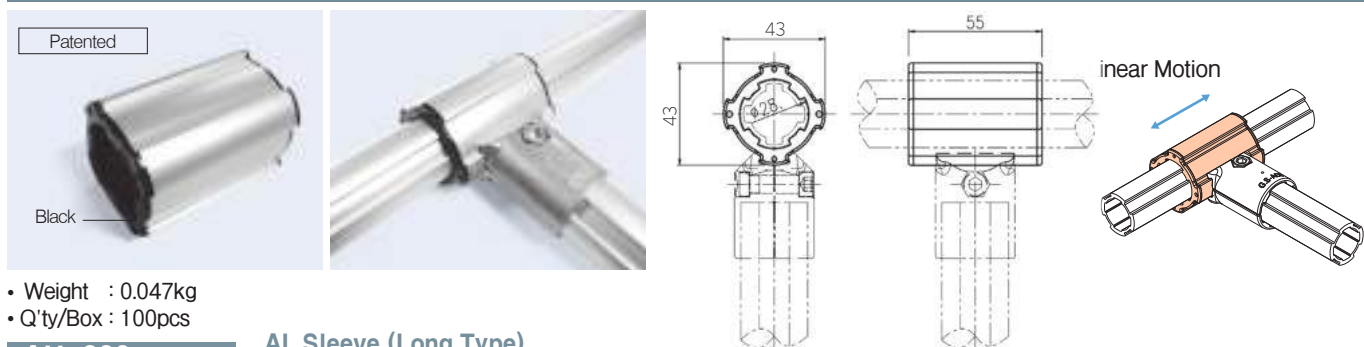

- Weight : 0.047kg
- Q'ty/Box : 100pcs

AH-800 AL Sleeve (Long Type)

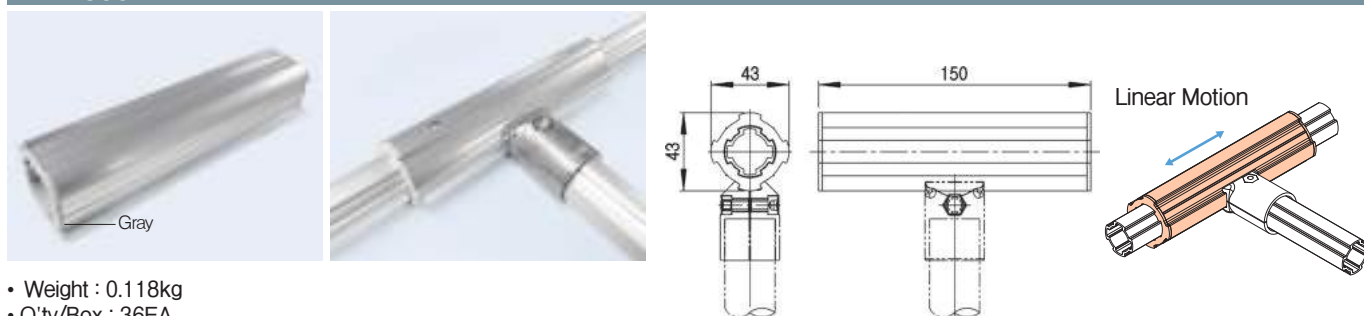

- Weight : 0.118kg
- Q'ty/Box : 36EA

Ø28 AL RACKING SYSTEM

ANP-01-150

알루미늄 명판

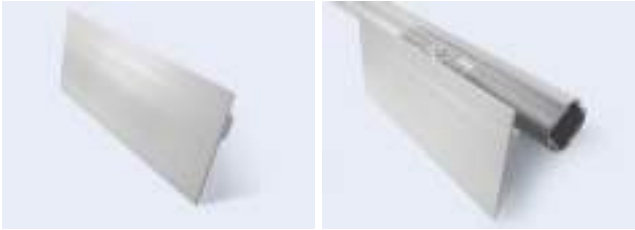

- Weight : 0.075kg
- Q'ty/Box : 150pcs

- ANP-01SA Standard Length : 4MT

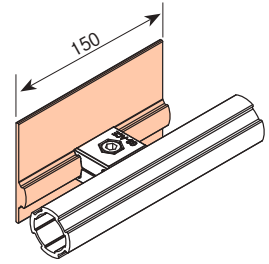
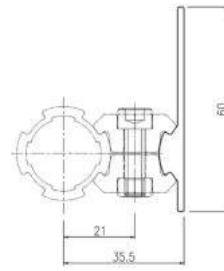

AOS-28A

Back Stopper



- Weight : 0.075kg
- Q'ty/Box : 70pcs

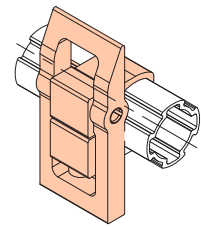
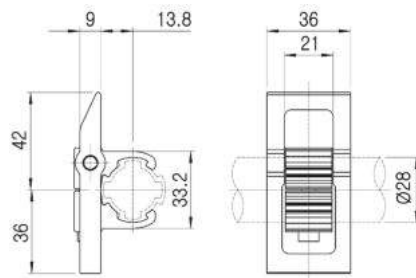

Applications of AOS-28A

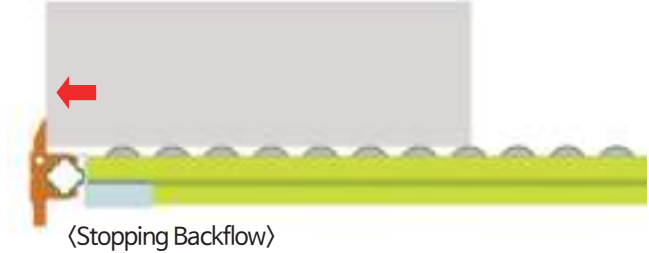

APC-01

Pipe Cover



- Weight : 0.050kg/m
- Q'ty/Bundle : 50pcs

- Standard Length : 3MT

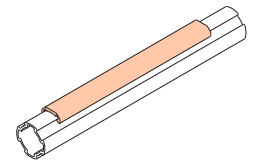
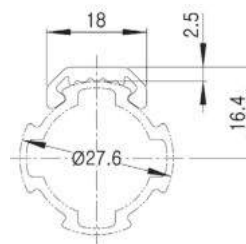

APC-03

Pipe Cover



- Weight : 0.151kg/m
- Q'ty/Bundle : 20pcs

- Standard Length : 3MT

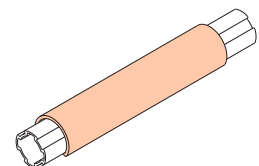
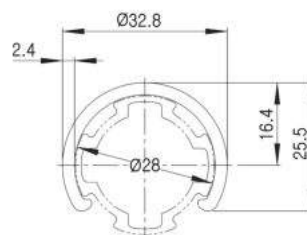

Ø28 AL RACKING SYSTEM

APHA-3027 Round Pipe Connected Joint

APH-3027A



APH-3027B



APHA-3027

- Weight : 0.031kg
- Q'ty/Box : 200pcs

- APH-3027A/B : 1set
- M0625 : 1pcs, PW06 : 1pcs

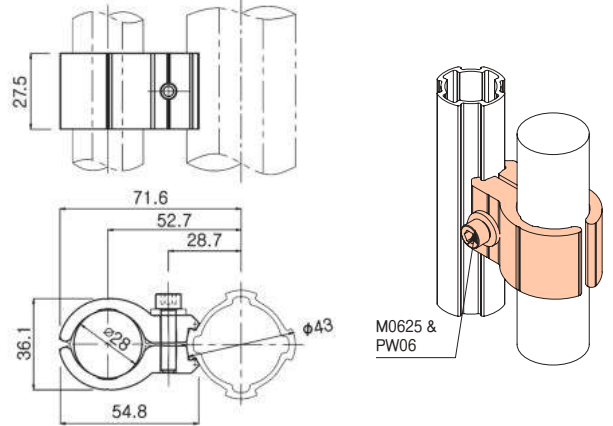

APHA-633N Round Pipe Connected Joint

디자인 등록

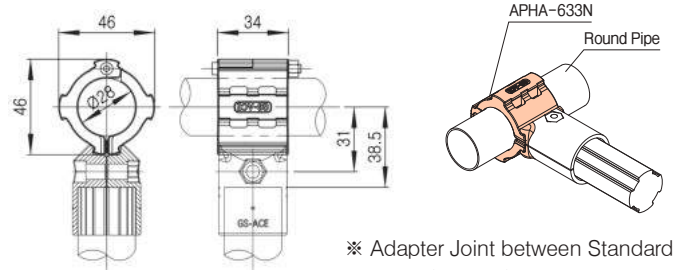

- Weight : 0.065kg
- Q'ty/Box : 120pcs

※ Adapter Joint between Standard Al Pipe(Profiled) and Round Pipe (Include Coated Pipe & STS Pipe)

ASG-03 AL Sheet Guide

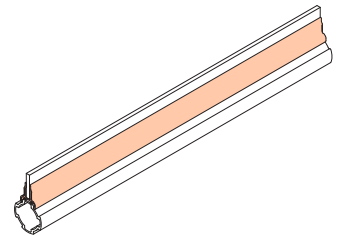
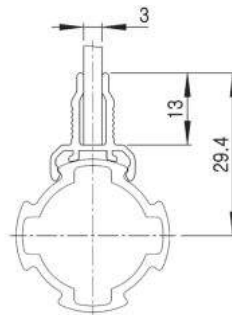

- Weight : 0.176kg/m
- Q'ty/Bundle : 20pcs

- .Standard Length : 4MT

ASG-05 AL Sheet Guide

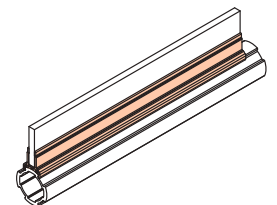
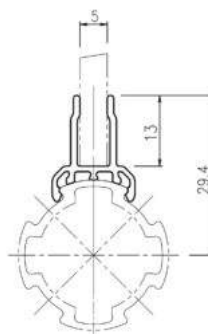

- Weight : 0.172kg/m
- Q'ty/Bundle : 20pcs

- .Standard Length : 4MT

Ø28 AL RACKING SYSTEM



ASG-05B

AL Sheet Guide



- Weight : 0.220kg
- Q'ty/Bundle : 20pcs

- Standard Length : 4MT

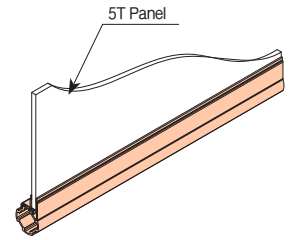
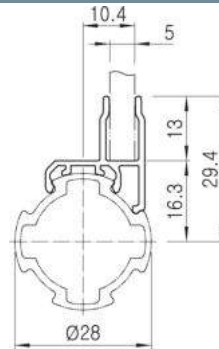

ASR-52

Slot Roller



- Weight : 0.034kg
- Q'ty/Box : 450pcs

- ASR-52:1EA, GB-02:1EA
- M6x30:1EA, SN406:1EA

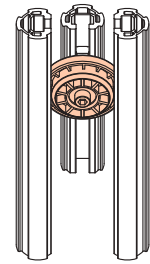
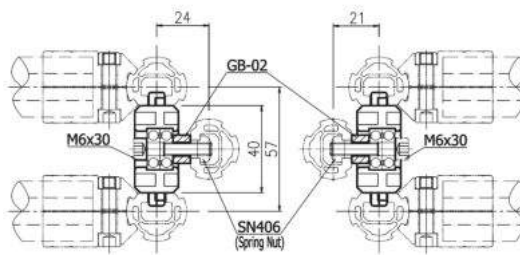

BA2800A/B

AL Thread Insert



- Weight : 0.017kg
- Q'ty/Box : 300pcs

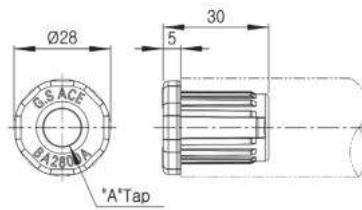

Part No.	"A" Tap	Remark
BA2800A	1/2"-12N	
BA2800B	M12-p1.75	

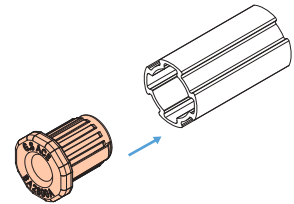

BA280LA/B/D/E

Metal Thread Insert

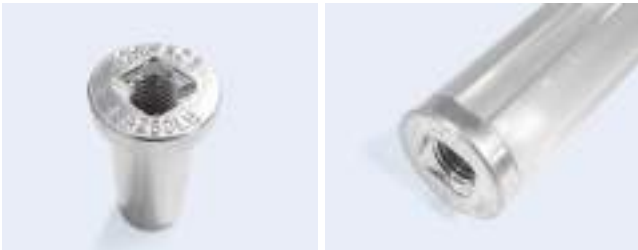

- Weight : 0.094kg
- Q'ty/Box : 160pcs

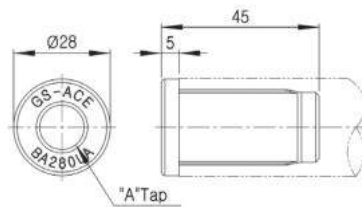

Part No.	"A" Tap	Remark
BA280LA	1/2"-12N	
BA280LB	M12-p1.75	
BA280LD	M10	
BA280LE	M8	

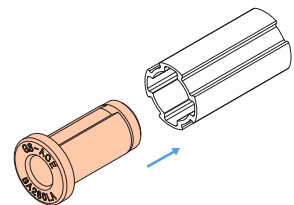

Ø28 AL RACKING SYSTEM

BA2818E

Metal Thread Insert (For AL2818)

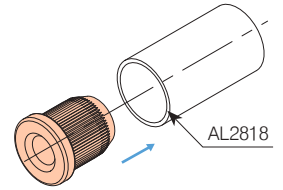
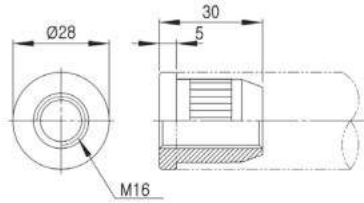

- Weight : 0.080kg
- Q'ty/Box : 200pcs

BP2800H

AL Plastic Thread Insert

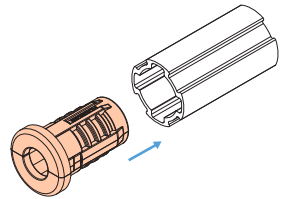
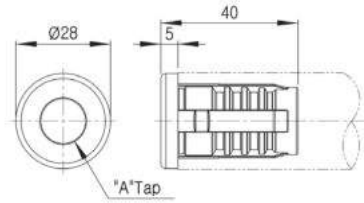
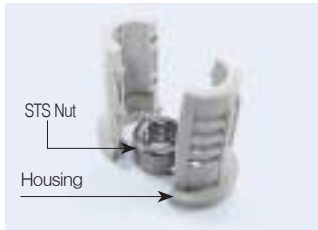

- Weight : 0.011kg
- Q'ty/Box : 1500pcs

- BP2800H : 2pcs
- N12S or N12S-12 : 1pcs

※ Housing			※ Nut		
Part No.	Colors	Remark	"A" Tap	Part No.	Remark
BP2800	Gray		M12	N12S (SUS 304)	
			1/2"-12N	Ni05S-12 (SUS 304)	

GAP-3A

Outer Cap

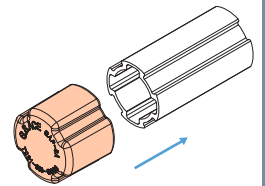
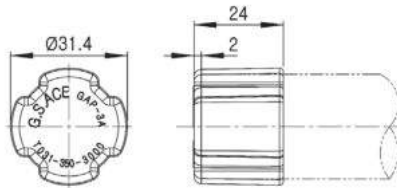

- Weight : 0.006kg
- Q'ty/Box : 900pcs

GAP-4A, E, H

Inner Cap

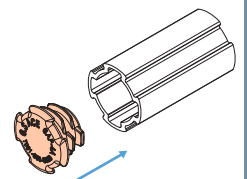
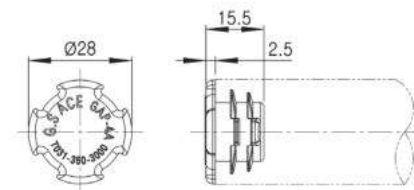

- Weight : 0.003kg
- Q'ty/Box : 1500pcs

Part No.	Colors	Material	Remark
GAP-4A	Gray	LDPE	
GAP-4E	Black	LDPE	ESD(대전방지)
GAP-4H	Black	PP	고강도

GAP-4AT

내경 캡 (AT2829용)

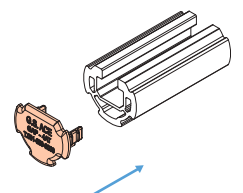
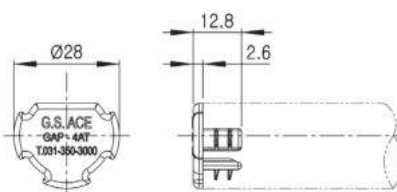

- Weight : 0.002kg
- Q'ty/Box : 3000pcs

Ø28 AL RACKING SYSTEM

HG-143 BK/PG Hand Grip



- Weight : 0.068kg
- Q'ty/Box : 150pcs
- Color : Black / Gray

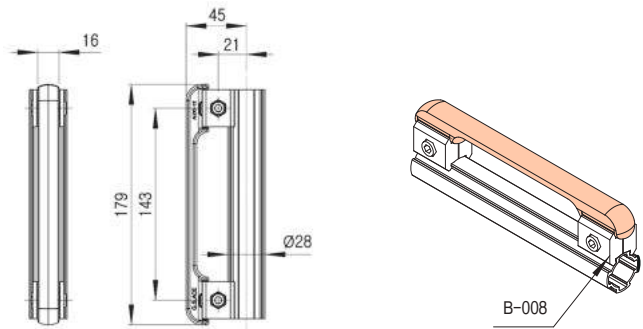

LAD-A Lifting Action Locking Device



- Weight : 0.210kg
- Q'ty/Box : 40pcs

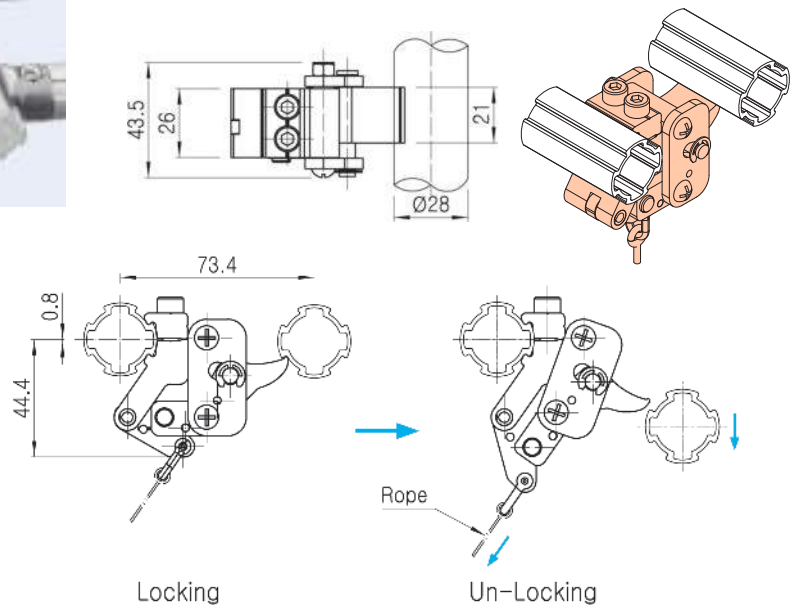

LP2800 ELF Plate

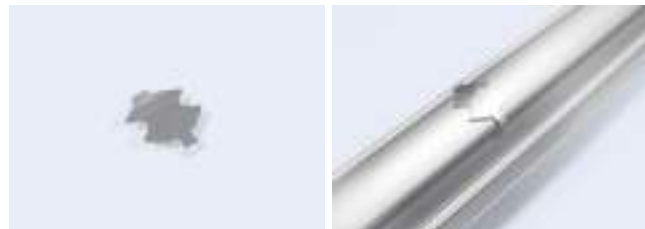

- Weight : 0.0002kg
- Q'ty/Box : 10000pcs

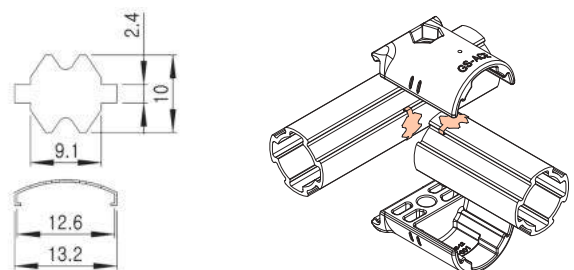

※ Refer to Technical Specification 245 Page

Ø28 AL RACKING SYSTEM

PRG-2805A/10A/20A/30A Pipe Roller Guide

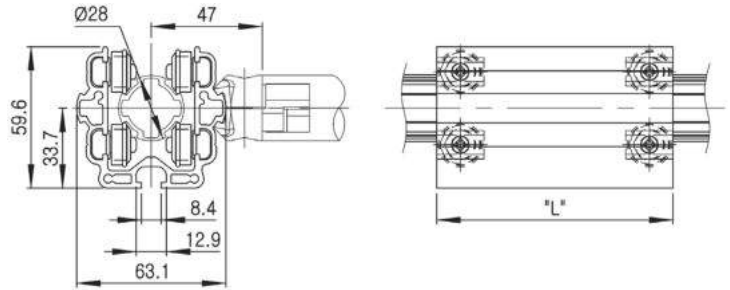

PART NO.	"L"	Weight	Q'ty/Box
PRG-2805A	50mm	220g	20EA
PRG-2810A	100mm	300g	10EA
PRG-2820A	200mm	460g	5EA
PRG-2830A	300mm	610g	4EA



PRG-2805B/10B/20B/30B Pipe Roller Guide (with Cover)

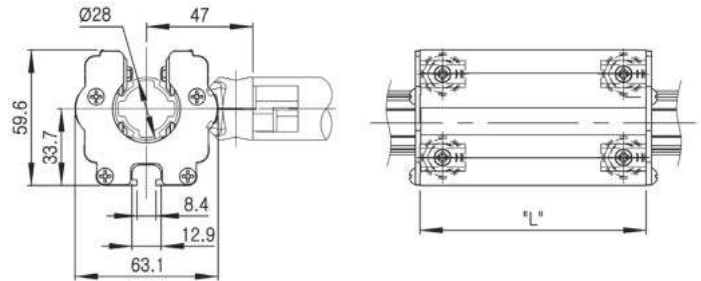

PART NO.	"L"	Weight	Q'ty/Box
PRG-2805B	50mm	290g	20EA
PRG-2810B	100mm	370g	10EA
PRG-2820B	200mm	530g	5EA
PRG-2830B	300mm	680g	4EA

LRA-19 Roller for Pipe Roller Guide



- Weight : 0.017kg
- Q'ty/Box : 600pcs
- LR-19 : 1EA
- PB-12 : 1EA
- M4x16 : 1EA, IN404 : 1EA
- Spring Washer : 1EA

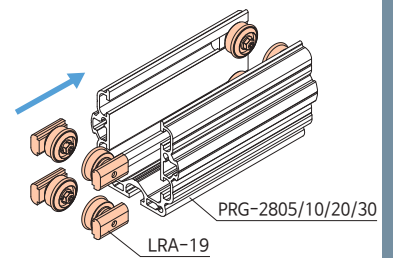
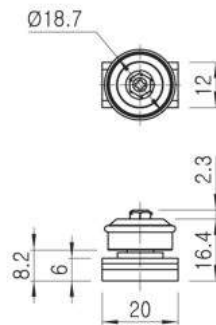

ACY-314A Cover for Pipe Roller Guide



- Weight : 0.036kg
- Q'ty/Box : 600EA
- Screw is sold separately (PH M4*10 WZ)

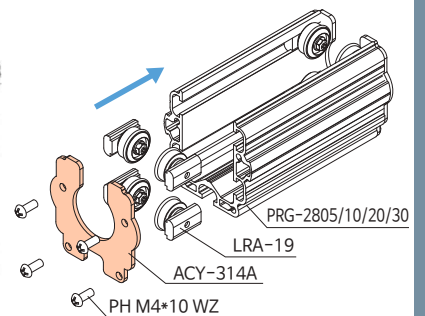
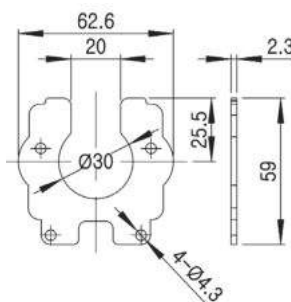

Ø28 AL RACKING SYSTEM

WEIGHT

Weight for Automation

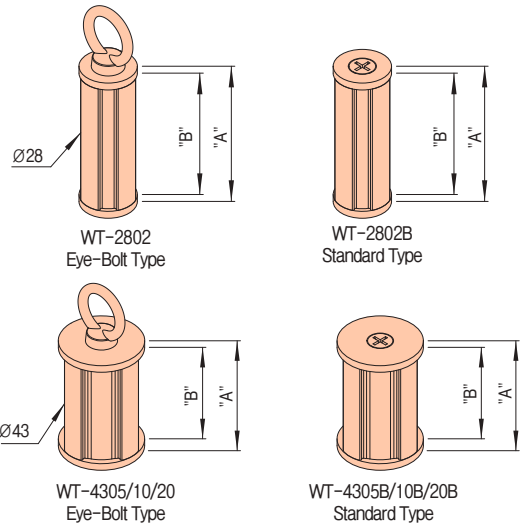

NO	ITEM NO	" A " Overall Length	" B " PIPE Length	Weight	Q'ty/Box
1	WT-2802/2802B	79 mm	70.0mm	0.25Kg ± 0.01Kg	45EA
2	WT-4305/4305B	64 mm	55.8mm	0.5Kg ± 0.01Kg	35EA
3	WT-4310/4310B	134 mm	125.9mm	1.0Kg ± 0.03Kg	16EA
4	WT-4320/4320B	276 mm	267.3mm	2.0Kg ± 0.05Kg	10EA

Ø33 AL RACKING SYSTEM

Ø33 ALUMINUM PIPE

AP3315

표준형 파이프



- Weight : 0.453kg/m, O.D Ø33

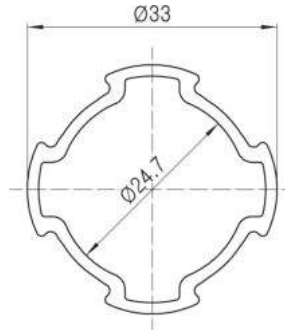

AP3315H

Heavy Duty Pipe



- Weight: 0.883kg/m, O.D Ø33

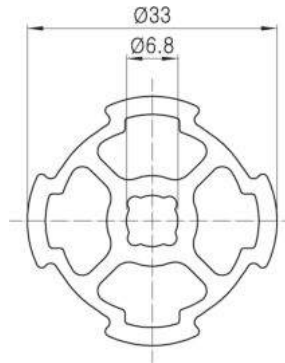

Ø33 AL RACKING SYSTEM

Ø33 ALUMINUM JOINT & ACCESSORIES

A-301

Single Tee Joint

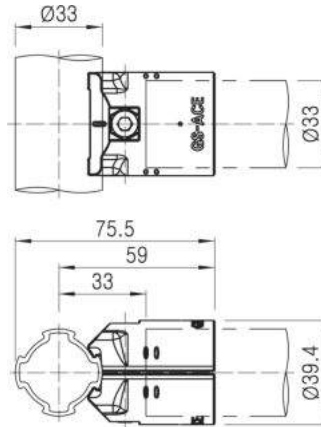

* Aluminum Outer Joint for $\phi 33$

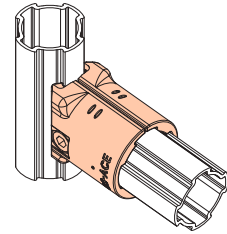

- Weight : 0.036kg
- Q'ty/Box : 120pcs

- A-301 : 2pcs
- M0630/N06W-55 : 1set
- Weight : 0.086kg
- Q'ty/Box : 60set

B-301

Single Tee Joint

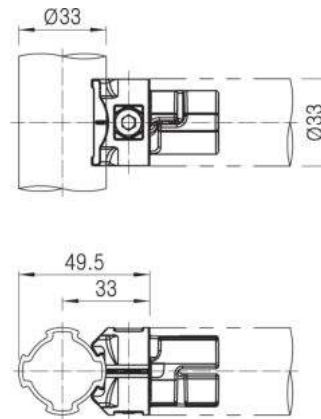

* Aluminum Inner Joint for $\phi 33$

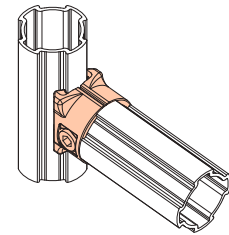

- Weight : 0.032kg
- Q'ty/Box : 200pcs

- B-301 : 2pcs
- M0625/N06W-55 : 1set
- Weight : 0.074kg
- Q'ty/Box : 100set

BA3300A,B,D

Metal Thread Insert

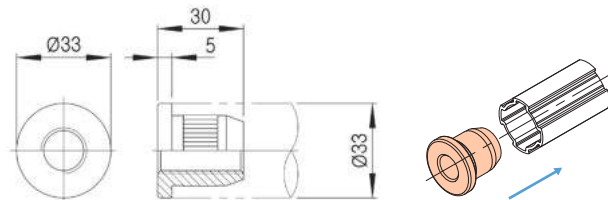

- Weight : 0.098kg
- Q'ty/Box : 160pcs

Part No.	"A" Tap	Remark
BA3300A	1/2"	
BA3300B	M12	
BA3300D	M10	

GAP-33A

Plastic Inner Cap

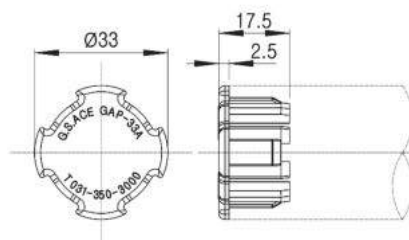

* Plastic Inner Cap for $\phi 33$

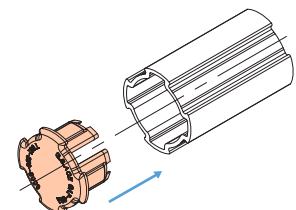

- Weight : 0.004kg
- Q'ty/Box : 1200pcs

Ø43 AL RACKING SYSTEM

Ø43 ALUMINUM PIPE

AP4319C Regular Duty Pipe



- Weight: 0.735kg/m, O.D Ø43

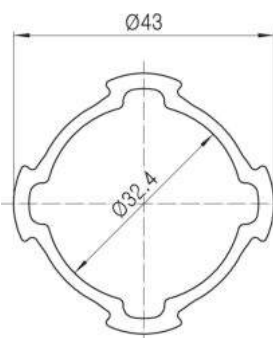

AP4319H Extra Heavy Duty Pipe



- Weight : 1.284kg/m, O.D Ø43

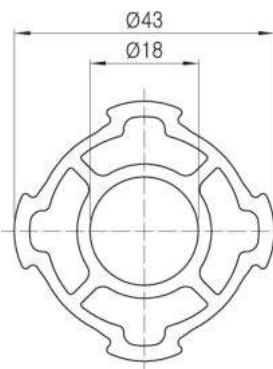

AQ4320 Hand Rail AL Pipe



- Weight: 0.903kg/m, O.D Ø43

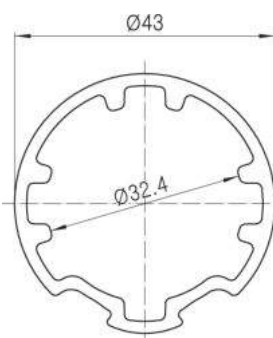

AD4319 Extra Heavy Duty Double Pipe



- Weight : 1.887kg/m, O.D Ø43

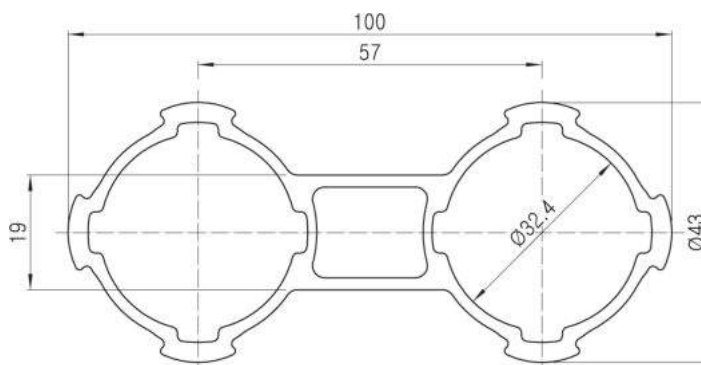

Ø43 AL RACKING SYSTEM

◆ Outer Joints

Ø43 ALUMINUM JOINTS

A-401

Single Tee Joint



AA-401

- Weight : 0.077kg
- Q'ty/Box : 60pcs

- A-401 : 2pcs
- M0840/N08 : 1set
- Weight : 0.178kg
- Q'ty/Box : 30set

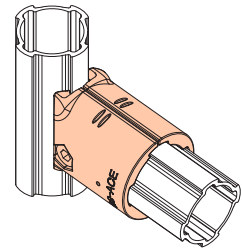

A-401W

Single Tee Joint (Heavy Duty)



AA-401W

- Weight : 0.123kg
- Q'ty/Box : 40pcs

- A-401W : 2pcs
- M0840/N08 : 1set
- Weight : 0.270kg
- Q'ty/Box : 20set

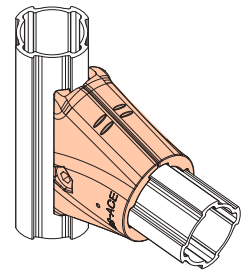
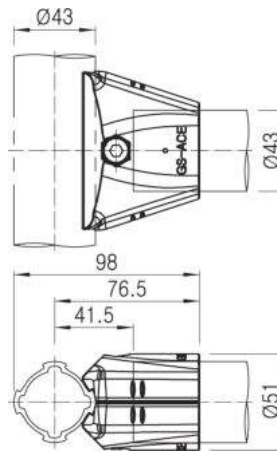

A-407B

Swivel Joint (Angle Adjust & Fix)



AA-407F

- Weight : 0.102Kg
- Q'ty/Box : 40pcs

- B-407A : 2pcs, • Weight : 0.370kg
- A-407B : 2pcs, • Q'ty/Box : 20set
- M0840/N08 : 1set
- M0830/N08 : 1set

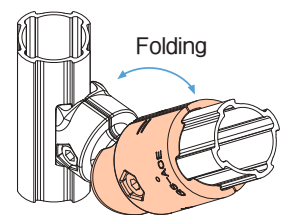
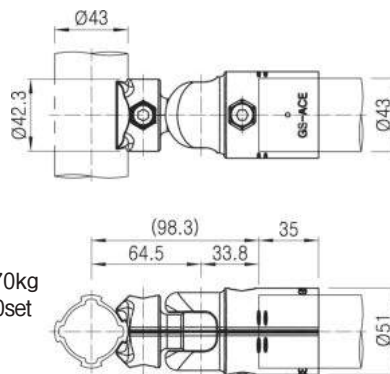

A-413L, A-413R 45° Joint



AA-413

- Weight : 0.082kg
- Q'ty/Box : 50pcs

- A-413L : 1EA, A-413R : 1EA
- M0840/N08 : 1set
- Weight : 0.188kg
- Q'ty/Box : 25set

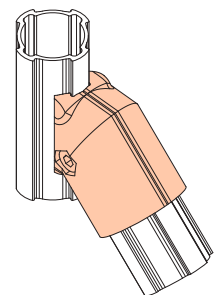
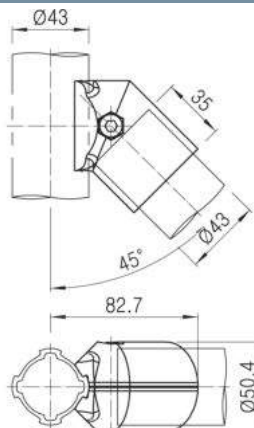

Ø43 AL RACKING SYSTEM



A-421

Single Tee Joint (Heavy Duty)



AA-421

- Weight : 0.137kg
- Q'ty/Box : 30pcs

- A-421 : 2pcs
- M0840/N08 : 1set
- Weight : 0.296kg
- Q'ty/Box : 15set

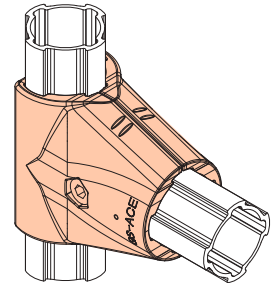
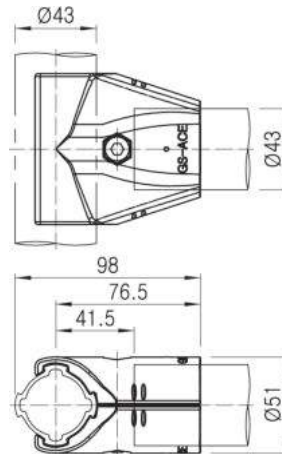

A-490

90° Elbow Joint



AA-490

- Weight : 0.131kg
- Q'ty/Box : 30pcs

- A-490 : 2pcs
- M0840/N08 : 1set
- Weight : 0.286kg
- Q'ty/Box : 15set

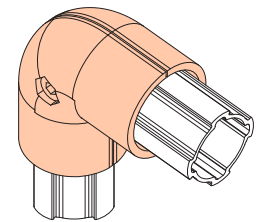
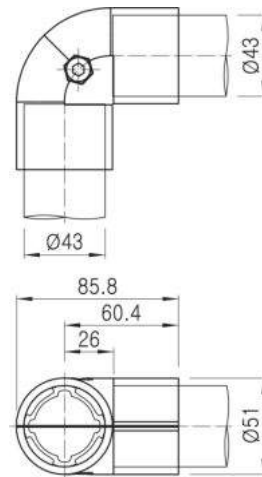

B-401

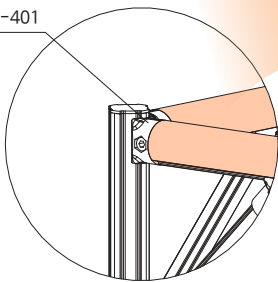

VIEW

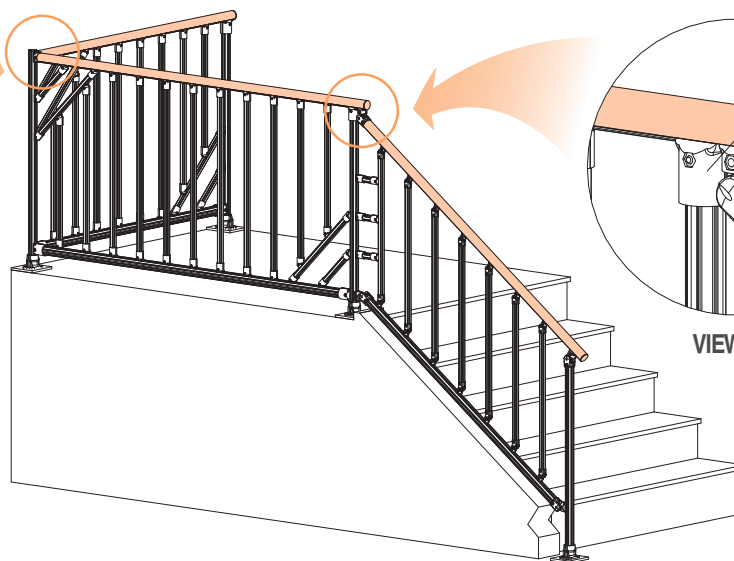

A-401

GAP-43B

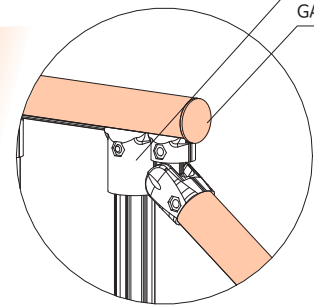

VIEW

Ø43 AL RACKING SYSTEM

◆ Inner Joints

B-401

Single Tee Joint



BA-401

- Weight : 0.061kg
- Q'ty/Box : 100pcs

- B-401 : 2pcs
- M0830/N08 : 1set
- Weight : 0.143kg
- Q'ty/Box : 50set

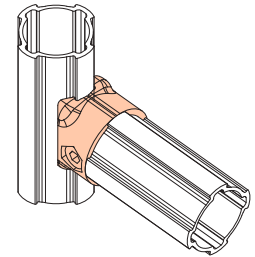
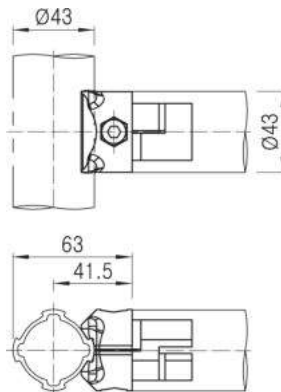

B-407A

Swivel Joint (Rotation, Angle Adjust & Fix)

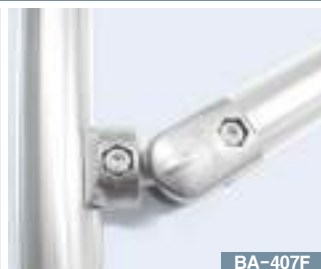

BA-407F

- Weight : 0.049kg
- Q'ty/Box : 120pcs

- B-407A : 2pcs, B-407B : 2pcs
- M0830/N08 : 2set
- Weight : 0.306kg
- Q'ty/Box : 20set

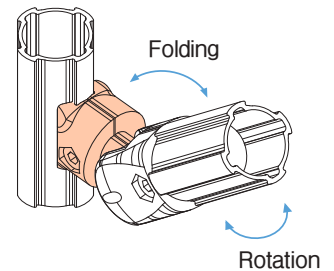
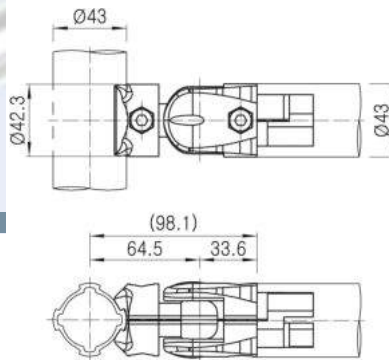

B-407B

Swivel Joint (Rotation, Angle Adjust & Fix)



BA-407F

- Weight : 0.083kg
- Q'ty/Box : 60pcs

- B-407A : 2pcs, B-407B : 2pcs
- M0830/N08 : 2set
- Weight : 0.306kg
- Q'ty/Box : 20set

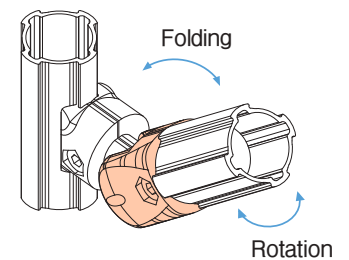
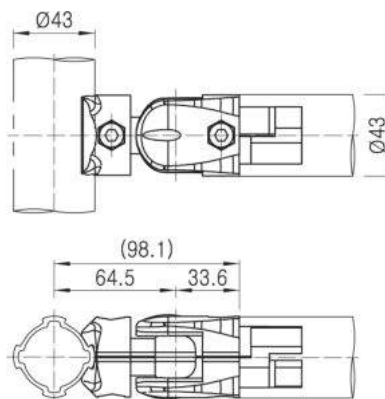

B-407C

Swivel Joint (Rotation, Angle Adjust & Fix)



BA-427F

- Weight : 0.070kg
- Q'ty/Box : 60pcs

- B-407B : 2pcs, B-407C : 2pcs
- M0830/N08 : 2set
- Weight : 0.306kg
- Q'ty/Box : 20set

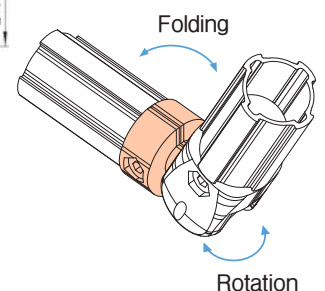
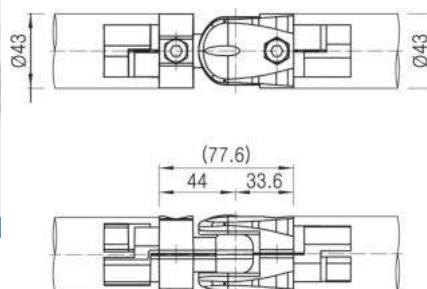

Ø43 AL RACKING SYSTEM

B-411

Parallel Joint



BA-411

- Weight : 0.051kg
- Q'ty/Box : 100pcs

- B-411 : 2pcs
- M0620/N06W-55 : 2set
- Weight : 0.120kg
- Q'ty/Box : 50set

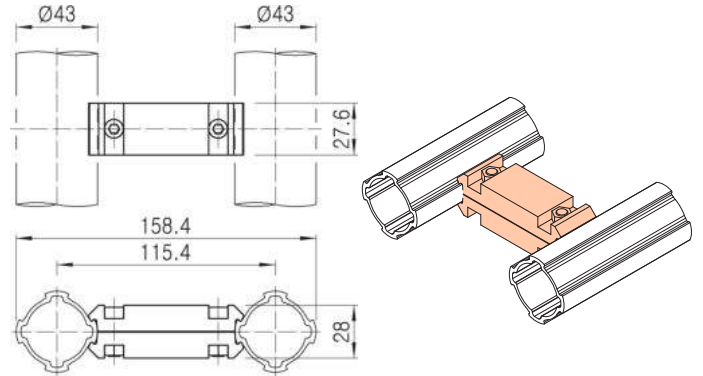

B-444

Straight Connector Joint



BA-444

- Weight : 0.086kg
- Q'ty/Box : 60pcs

- B-444 : 2pcs
- M0830/N08 : 2set
- Weight : 0.140kg
- Q'ty/Box : 30set

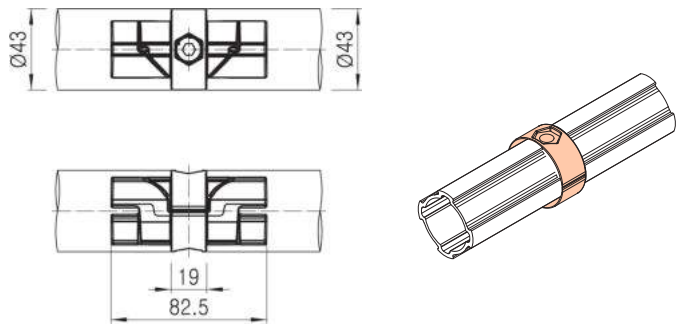

B-445

Corner Joint



<BA-445>

- Weight : 0.060kg
- Q'ty/Box : 60pcs

- B-445 : 2pcs
- M0620/N06W-55 : 1set
- Weight : 0.135kg
- Q'ty/Box : 30set

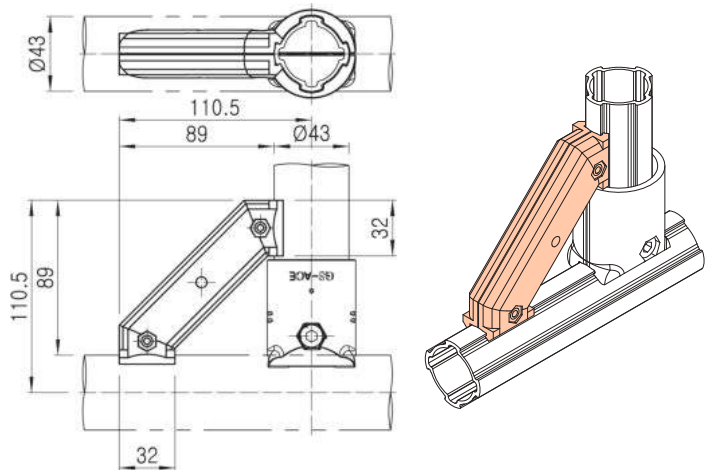

B-490

90° Elbow Joint



<BA-490>

- Weight : 0.126kg
- Q'ty/Box : 30pcs

- B-490 : 2pcs
- M0830/N08 : 1set
- Weight : 0.271kg
- Q'ty/Box : 15set

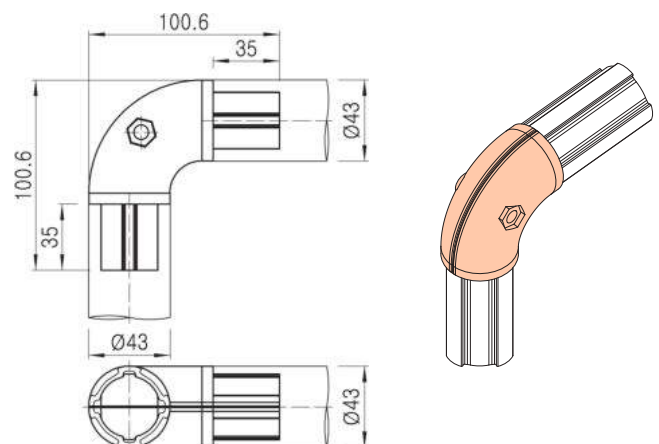

Ø43 AL RACKING SYSTEM

Ø43 ALUMINUM & ACCESSORIES

A-104

Profile Joint



<AA-104>

- Weight : 0.102kg
- Q'ty/Box : 20pcs

- A-104 : 2pcs
- M0615/N06W-55 : 2set
- Weight : 0.219kg
- Q'ty/Box : 10set

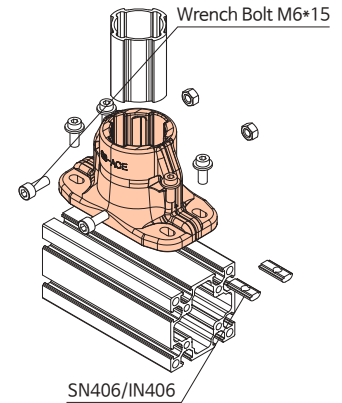
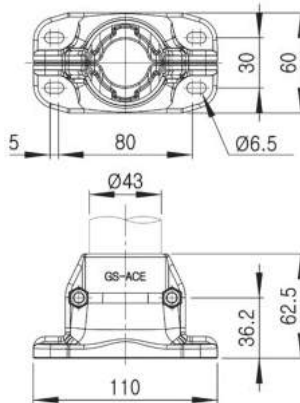

A43-N301

Aluminum Stanchion Mount



- Weight : 0.034kg
- Q'ty/Box : 150pcs

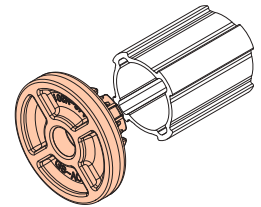
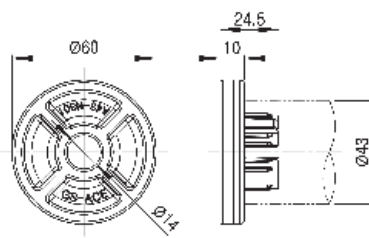

A43-N303

Board Support for Ø43



- Weight : 0.007kg
- Q'ty/Box : 400pcs

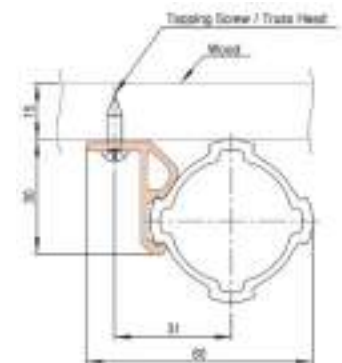
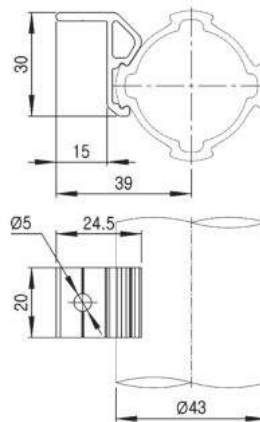

ABS-0530

Board Support for Ø43



- Weight : 0.037kg
- Q'ty/Box : 100pcs

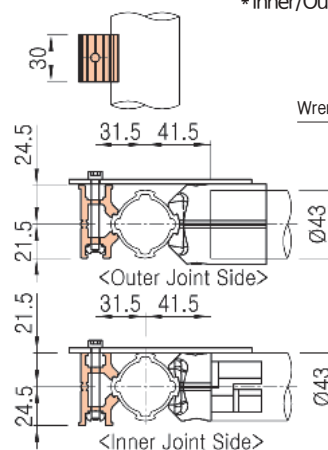

* Inner/Outer Board Support for assembling Panel after Ø43 Aluminum Joint assembly

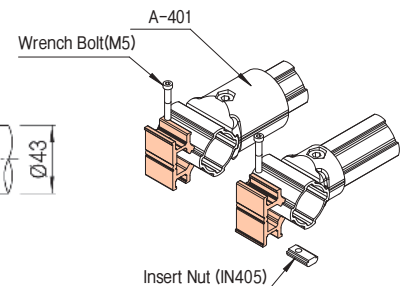

Ø43 AL RACKING SYSTEM

ABS-4320A Board Support for $\phi 43$



- Weight : 0.020kg
- Q'ty/Box : 200pcs

- ABS-4320A : 1pcs, APC-01 : 1pcs
- M0540 : 1pcs

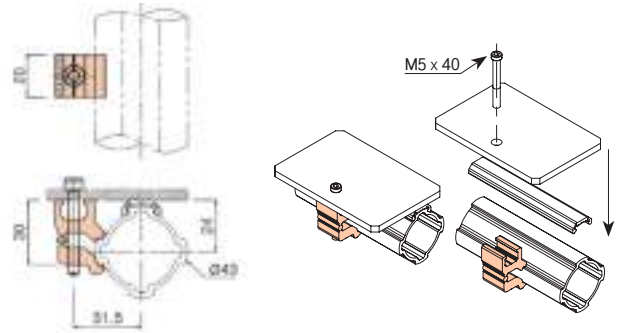

ABS-4320C Board Support for $\phi 43$



- Weight : 0.019kg
- Q'ty/Box : 200pcs

* Height adjusting Board Support for assembling Panel after assembling Pipe with Profile

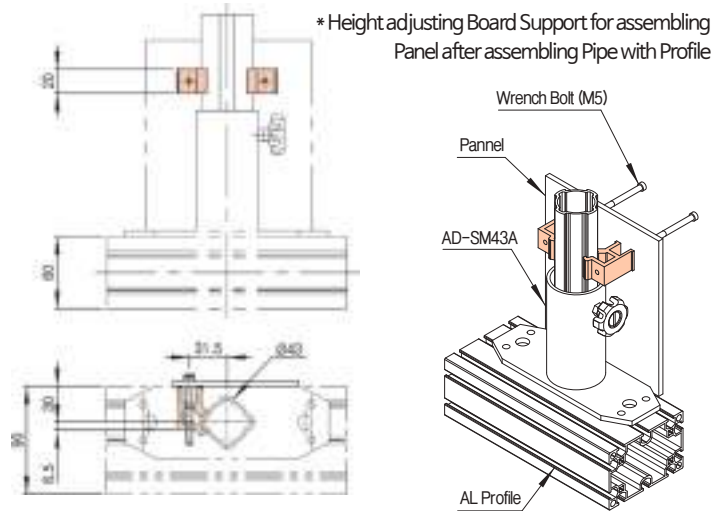

ABS-4320D Inner Board Support for $\phi 43$



- Weight : 0.020kg
- Q'ty/Box : 200pcs

* Inner Board Support for assembling Panel after $\phi 43$ Aluminum Inner Joint assembly

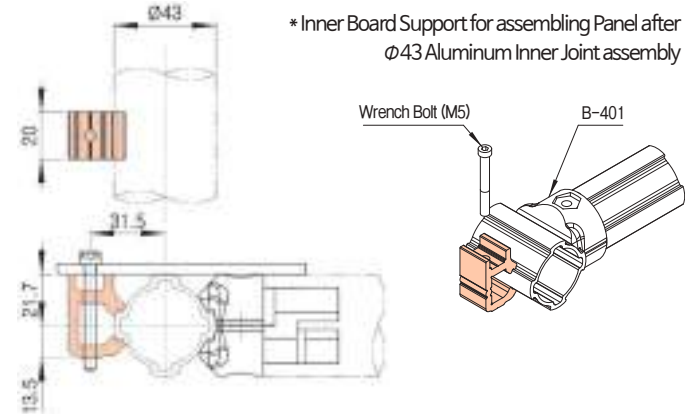

ABS-4320E Outer Board Support for $\phi 43$



- Weight : 0.022kg
- Q'ty/Box : 200pcs

* Outer Board Support for assembling Panel after $\phi 43$ Aluminum Outer Joint assembly

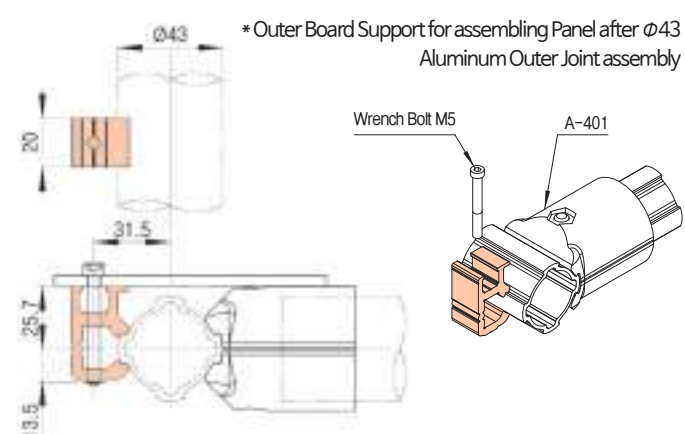

Ø43 AL RACKING SYSTEM

ACHA-6040A AL Component Holder

ACH-6040A-L



- Weight : 0.017kg
- Q'ty/Box : 400pcs

ACH-6040A-R



- Weight : 0.033kg
- Q'ty/Box : 100pcs



<ACHA-6040A>

- ACH-6040A-L/R : 1set
- M0612 : 1pcs, SN406 : 1EA
- Q'ty/Box : 75set

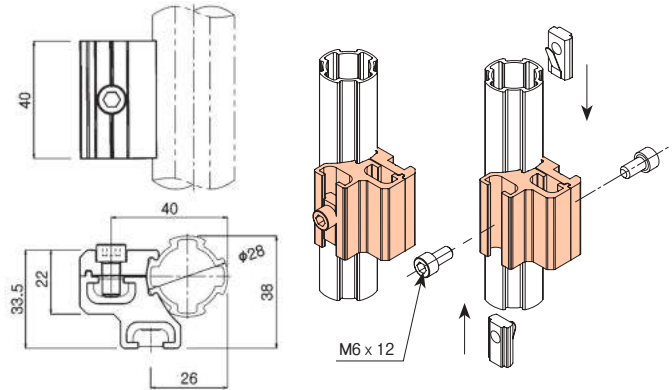

AD-SM43A Stanchion Mount Single



- Weight : 0.680kg
- Q'ty/Box : 40pcs



<ADA-SM43A>

- AD-SM43A : 1pcs
- HM0615 : 1pcs
- Weight : 0.680kg
- Q'ty/Box : 40set

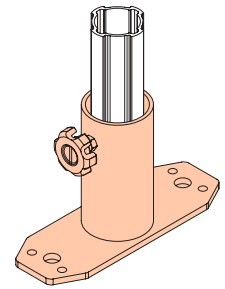
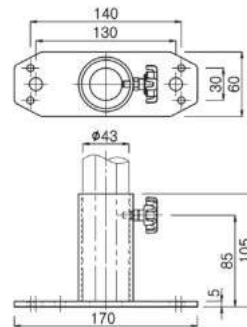

AD-SM43L Stanchion Mount Single-Left



- Weight : 0.680kg
- Q'ty/Box : 40pcs



<ADA-SM43L>

- AD-SM43L : 1pcs
- HM0615 : 1pcs
- Weight : 0.680kg
- Q'ty/Box : 40set

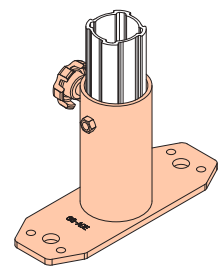
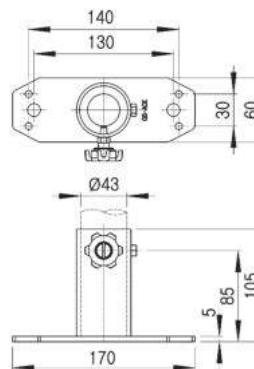

AD-SM43R Stanchion Mount Single-Right



- Weight : 0.680kg
- Q'ty/Box : 40pcs



<ADA-SM43R>

- AD-SM43R : 1pcs
- HM0615 : 1pcs
- Weight : 0.680kg
- Q'ty/Box : 40set

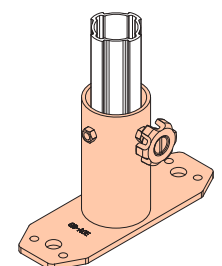
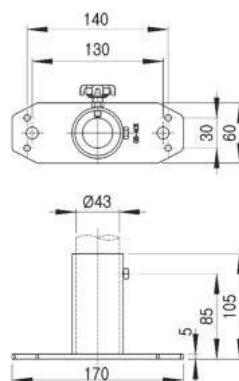

Ø43 AL RACKING SYSTEM

ACM-600

AL Caster Mount

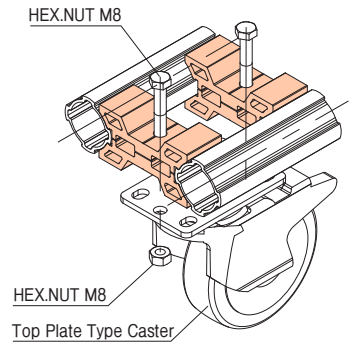
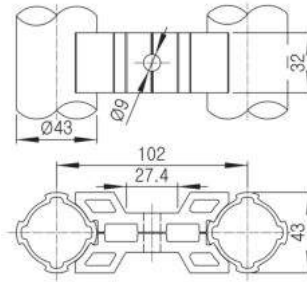

- Weight : 0.068kg
- Q'ty/Box : 60pcs

AMB-0654

Mount Bracket

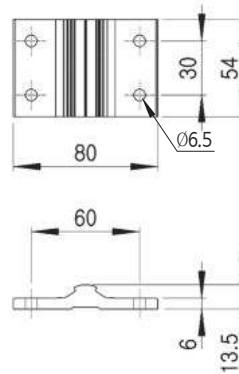

* Mount Bracket for assembling Aluminum Pipe with Profile

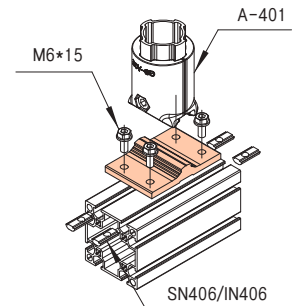

- Weight : 0.083kg
- Q'ty/Box : 100pcs

AMB-0684

Mount Bracket

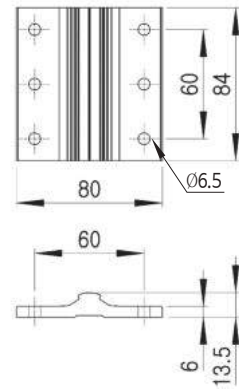

* Mount Bracket for assembling Aluminum Pipe with Profile

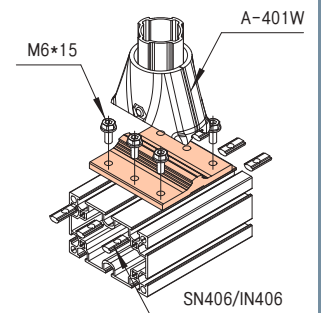

- Weight : 0.129kg
- Q'ty/Box : 50pcs

Ø43 AL RACKING SYSTEM

ASG-4305

AL Sheet Guide for Ø43



- Weight : 0.956kg/m
- Q'ty/Bundle : 20pcs
- Standard Length : 4MT

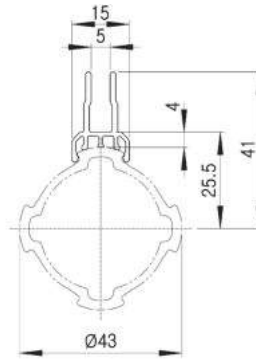

* AL Sheet Guide for Ø43

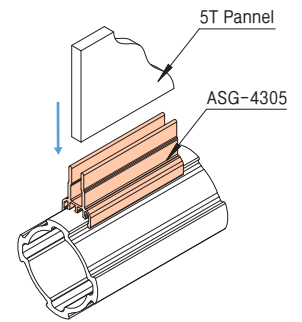

BA4300A/B/D

AL Thread Insert



- Weight : 0.032kg
- Q'ty/Box : 150pcs

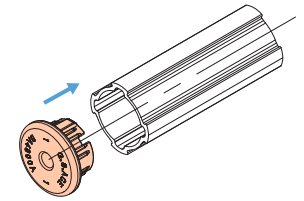
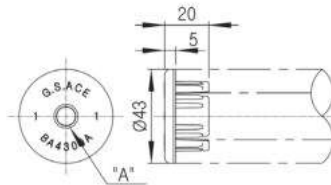

Part No.	"A" Tap	Remark
BA4300A	1/2"	
BA4300B	M12	
BA4300D	M10	

BA4300N

AL Cap



- Weight : 0.034kg
- Q'ty/Box : 150pcs

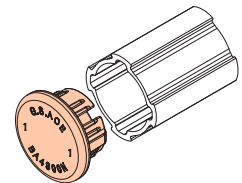
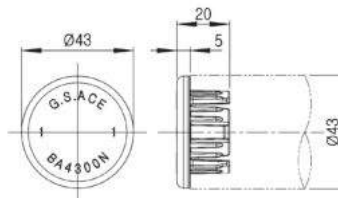

Ø43 AL RACKING SYSTEM

BP4300H AL Plastic Thread Insert

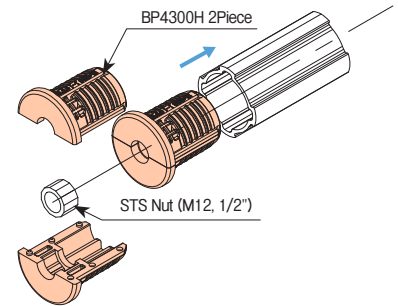
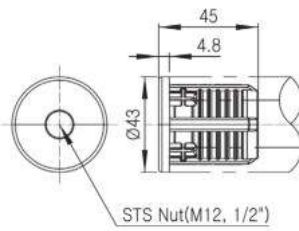

- Weight : 0.014kg
- Q'ty/Box : 800pcs

- BP4300H : 2pcs
- N12S or N12S-12 : 1pcs

GAP-43A Plastic Inner Cap

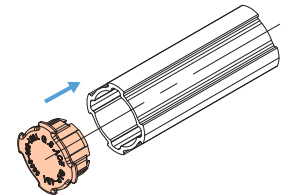
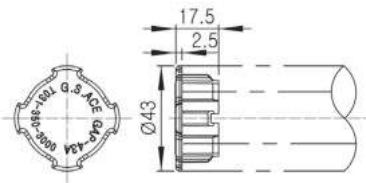

- Weight : 0.005kg
- Q'ty/Box : 600pcs

GAP-43B Plastic Round Inner Cap

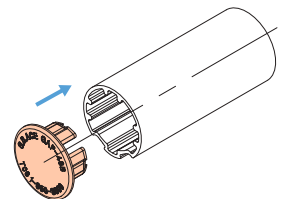
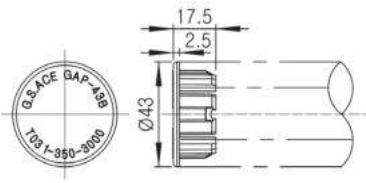

- Weight : 0.007kg
- Q'ty/Box : 600pcs

28 X 28 ALUMINUM RACKING SYSTEM

ALUMINUM SQUARE RACKING SYSTEM SPECIAL FEATURES

- Easier Assembly than Aluminum Profiles (Reduce assembly time by 40%)
- No Exterior Groove (No Need to fill T-Groove when using in cleanroom)
- Low Cost and Lightweight Compared to Aluminum Profile
- Flat Rack Possible by Linking Aluminum Square Pipe with Joint (Easy to fix plate and parts with flat square rack)
- Compatible with Circular Ø28 Aluminum Pipes and Joints (Compatible with Existing Circular Ø28 Aluminum Pipes and Joints and Various Accessories)



28 X 28 ALUMINUM RACKING SYSTEM

* Surface Treatment – PE-Coating

ASQ2812A 90° 2-Way Linking Square Pipe

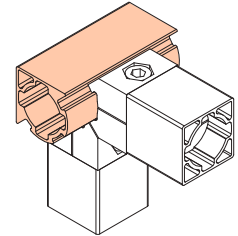
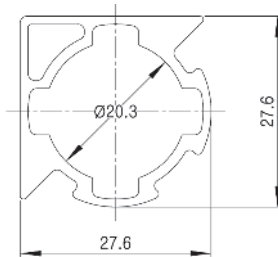
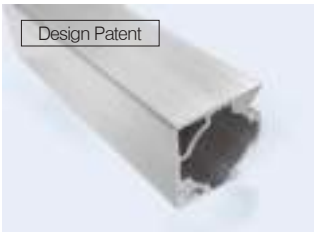

- Weight : 0.566kg/m
- Q'ty/Bundle : 8EA

ASQ2812B 180° 2-Way Linking Square Pipe

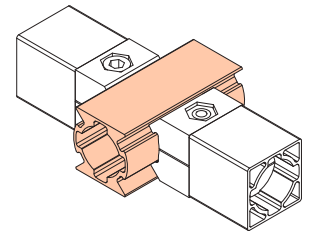
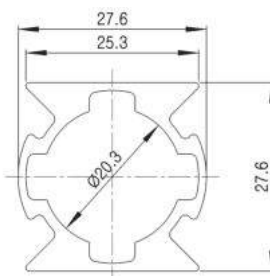
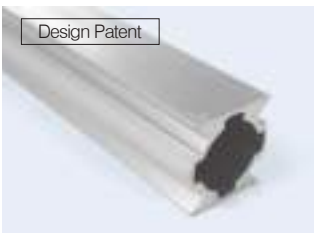

- Weight : 0.665kg/m
- Q'ty/Bundle : 8EA

ASQ2812C 1-Way Linking Square Pipe

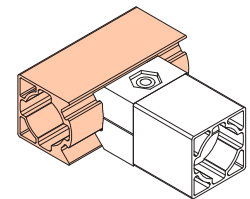
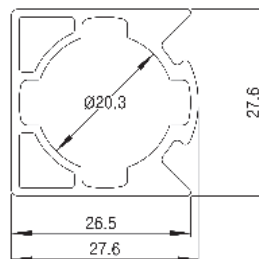
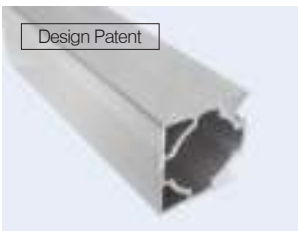

- Weight : 0.591kg/m
- Q'ty/Bundle : 8EA

ASQ2812D Square Pipe to Prevent Foreign Particles from Entering

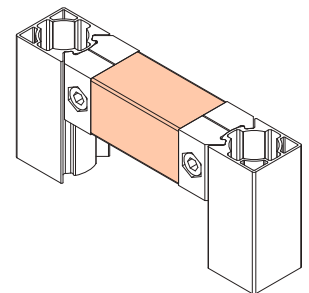
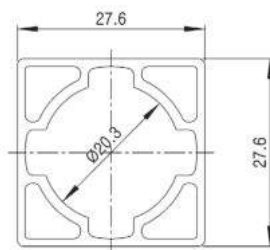
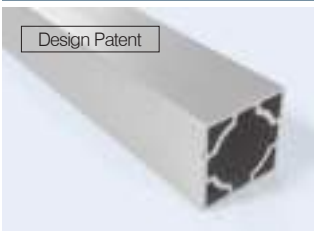

- Weight : 0.555kg/m
- Q'ty/Bundle : 8EA

ASQ2812E 3-Way Linking Square Pipe

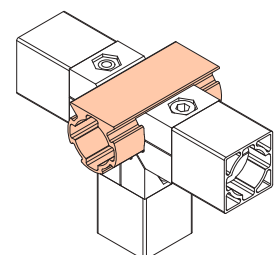
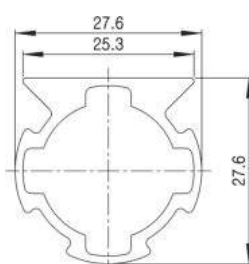

- Weight : 0.522kg/m
- Q'ty/Bundle : 8EA

28 X 28 ALUMINUM RACKING SYSTEM

ASQ2812F

L-Type Square Pipe to Prevent Foreign Particles from Entering



- Weight : 0.646kg/m
- Q'ty/Bundle : 6EA

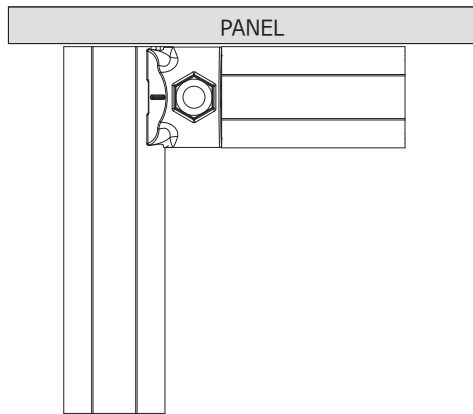
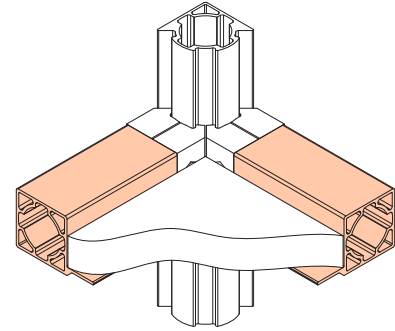
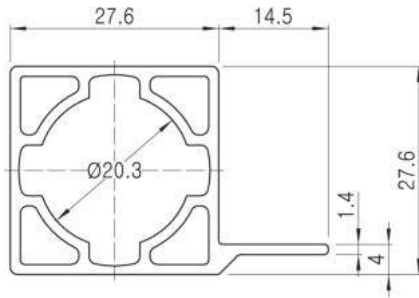

〈Panel Attachment for AL Rack assembled with Standard AL Pipe〉

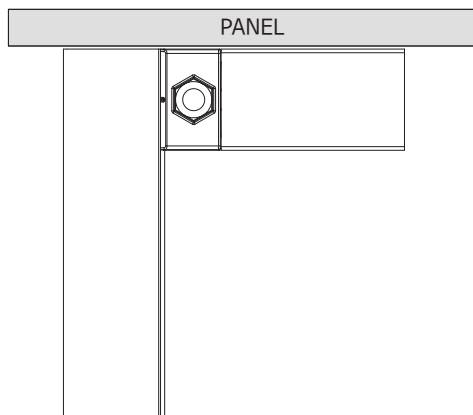
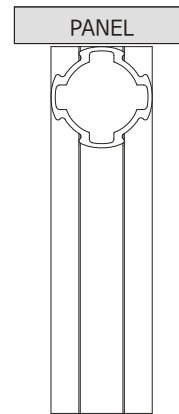

〈Panel Attachment for AL Rack assembled with Square AL Pipe〉

28 X 28 ALUMINUM RACKING SYSTEM

28x28 ALUMINUM JOINT & ACCESSORIES

Unit : mm

C-001

Square Joint for 28x28

Patent Pending

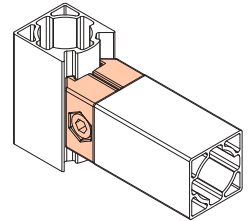
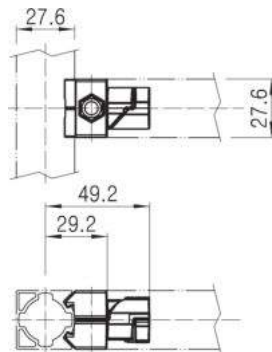

- Weight : 0.021kg
- Q'ty/Box : 200pcs

- C-001 : 2pcs
- M0620/N06W-55 : 1set
- Weight : 0.050kg
- Q'ty/Box : 100set

※ Recommend that the pipe linking with the joints are calculated by floating 30mm from the center of the pipe



GAP-2828A

Inner Cap for 28x28

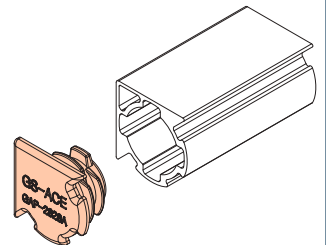
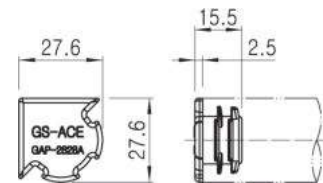

- Weight : 0.003kg
- Q'ty/Box : 1500pcs

GAP-2828D

Inner Cap for 28x28

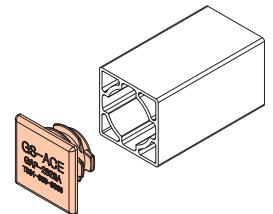
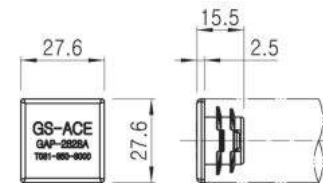

- Weight : 0.003kg
- Q'ty/Box : 1500pcs



GAP-2828E

Inner Cap for 28x28

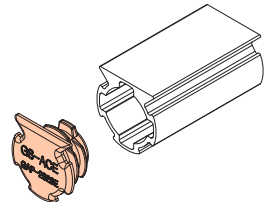
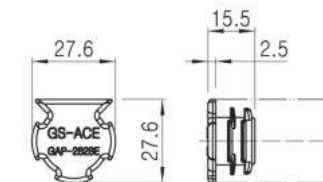

- Weight : 0.003kg
- Q'ty/Box : 1500pcs

BP2828A

Bushing Cap for 28x28

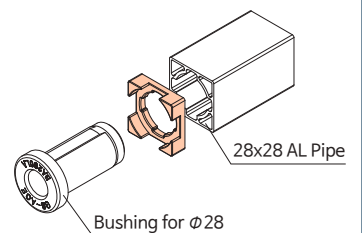
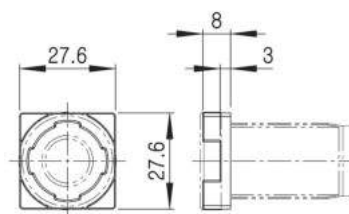

- Weight : 0.003kg
- Q'ty/Box : 1500EA

40 X 40 AL PROFILE RACKING SYSTEM

AL PROFILE RACKING SYSTEM

- More Convenient to assemble than Aluminum Profile (Reduce assembly time about 40 %)
- Smooth appearance without grooves (No need to T-backing when used in Clean Room)
- Lightweight and Low cost compared to Aluminum profile.
- Flat Rack Configuration with Aluminum Square pipe and Joint (Easy to assemble for flat surface and fix with accessories)
- Compatibility with $\varnothing 28$ & $\varnothing 43$ Aluminum Circular Pipe's Joint
- Can be used with existing Joint of $\varnothing 28$ and $\varnothing 43$ aluminum round pipe and various accessories
- Can be used T groove and various available accessories

How to assemble with Joint

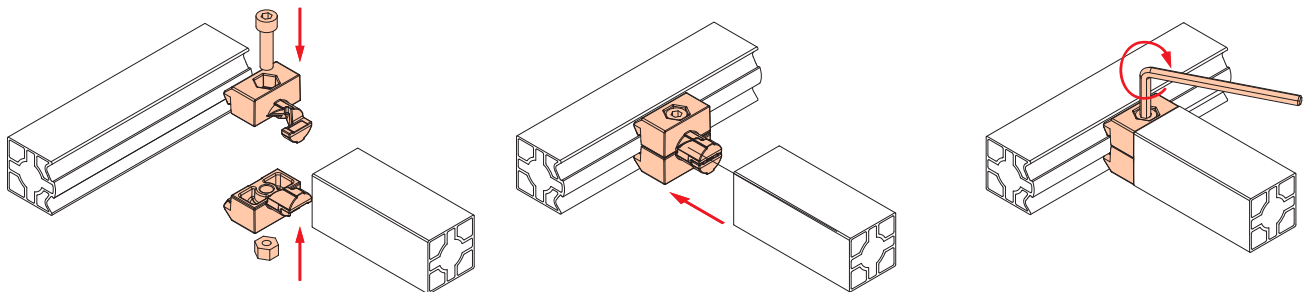

How to assemble using T-groove

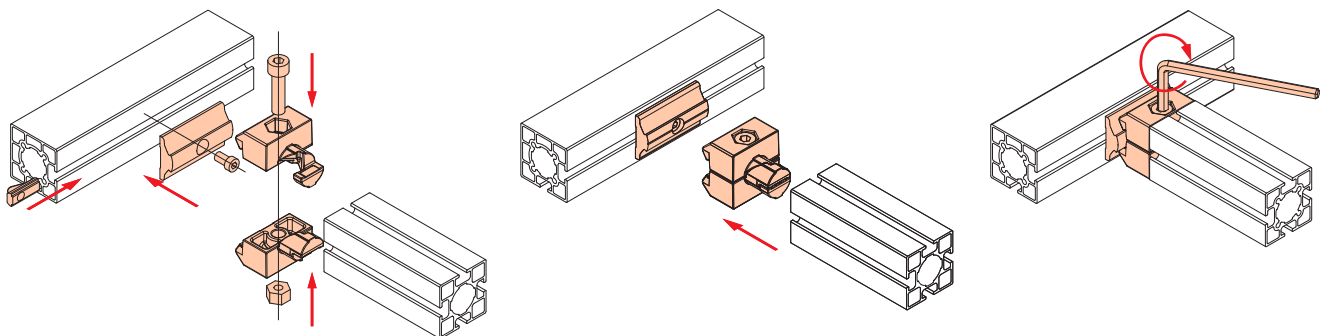

40 X 40 AL PROFILE RACKING SYSTEM

New Profile Application Example

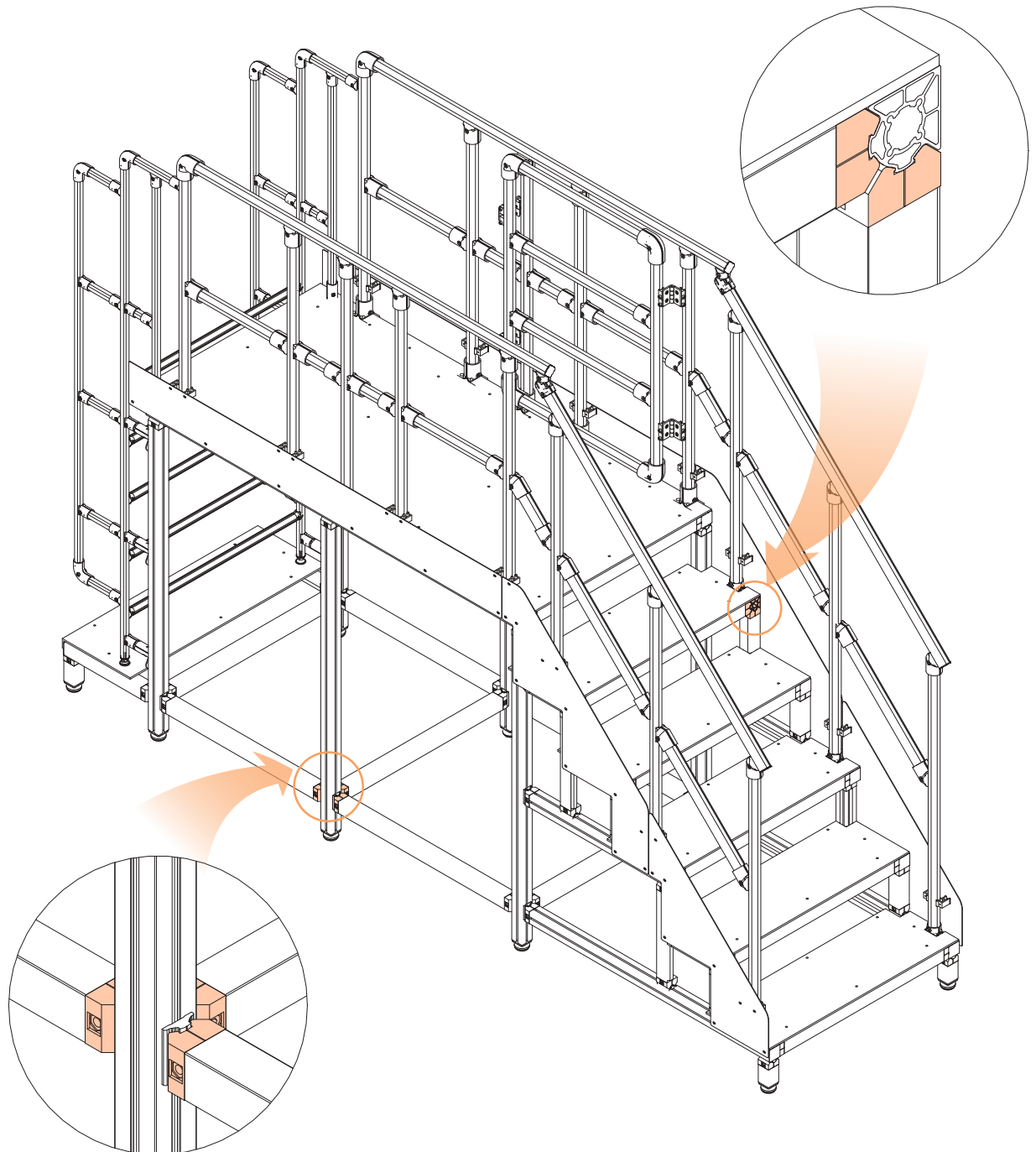

40 X 40 AL PROFILE RACKING SYSTEM

40X40 ALUMINUM PROFILE

Unit : mm

AL RACKING

ASJ4040A 90° 2-Way Joint Linking Profile

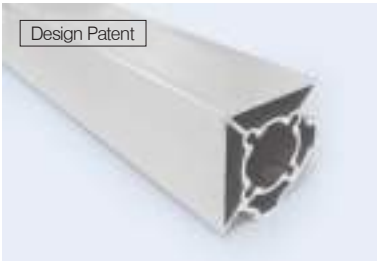

Material	A6063-T5
Weight	1.195 kg/m
Surface Treatment	PE-Coating

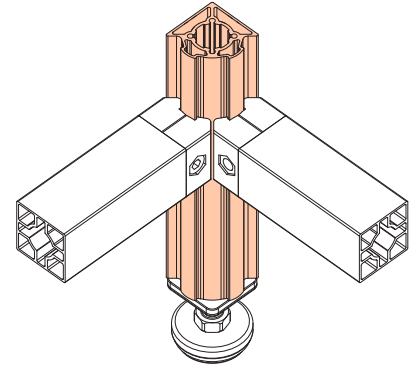
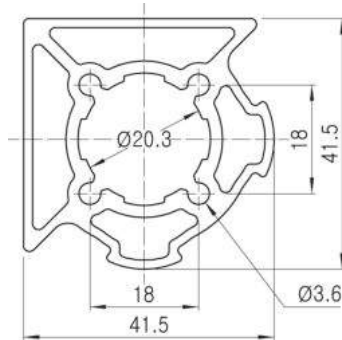

ASJ4040B 180° 2-Way Joint Linking Profile

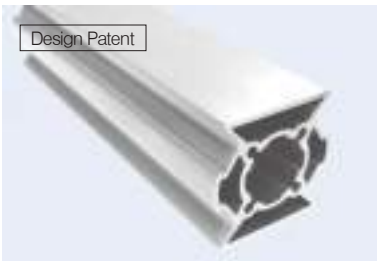

Material	A6063-T5
Weight	1.211 kg/m
Surface Treatment	PE-Coating

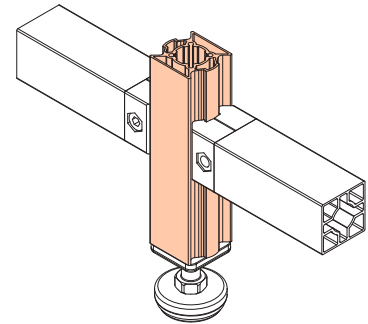
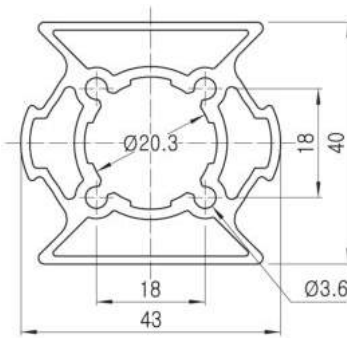

ASJ4040C 1-Way Joint Linking Profile

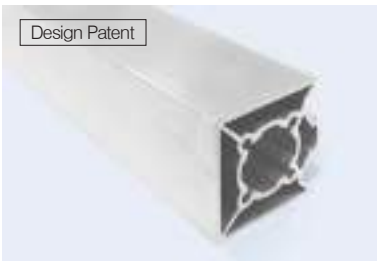

Material	A6063-T5
Weight	1.200 kg/m
Surface Treatment	PE-Coating

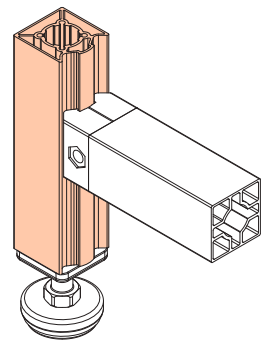
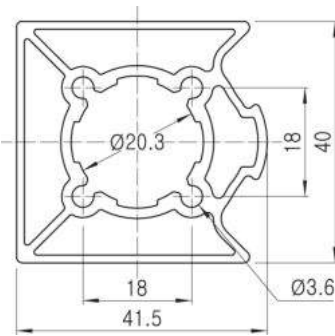

* Surface Treatment Option : Anodizing

ASJ4040D Profile to Prevent Foreign Particles from Entering

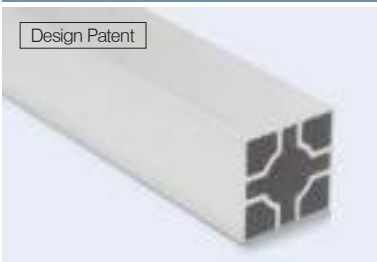

Material	A6063-T5
Weight	1.175 kg/m
Surface Treatment	PE-Coating

* Surface Treatment Option : Anodizing

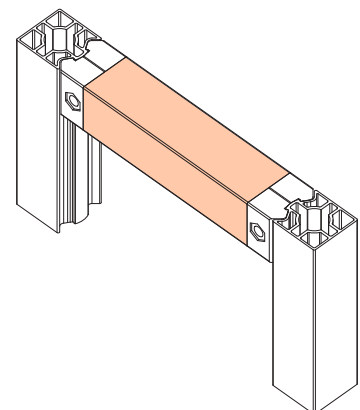
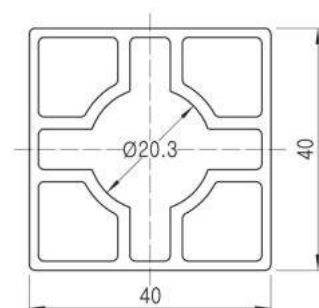

40 X 40 AL PROFILE RACKING SYSTEM

Unit : mm



ASJ4040E 3-Way Joint Linking Profile



Design Patent

Material	A6063-T5
Weight	1.145 kg/m
Surface Treatment	PE-Coating

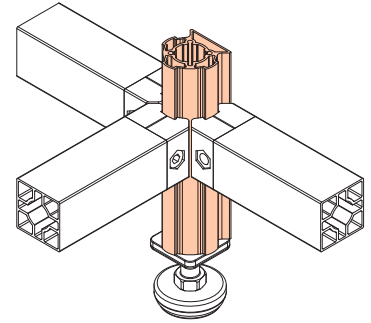
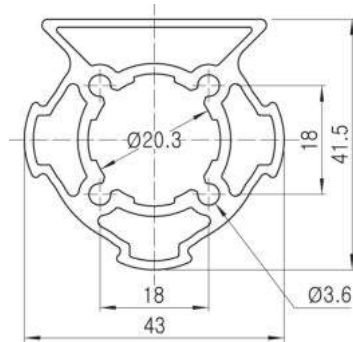

ASJ4040R Corner Round 90° 2-Way Joint Linking Profile



Material	A6063-T5
Weight	1.126 kg/m
Surface Treatment	PE-Coating

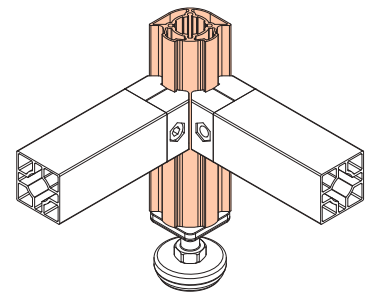
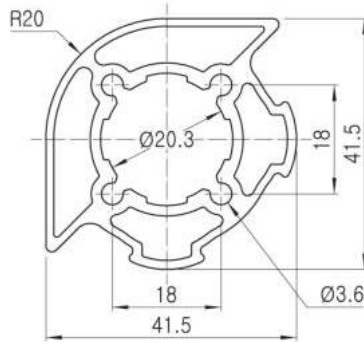

Joint Linking Profile Application Example

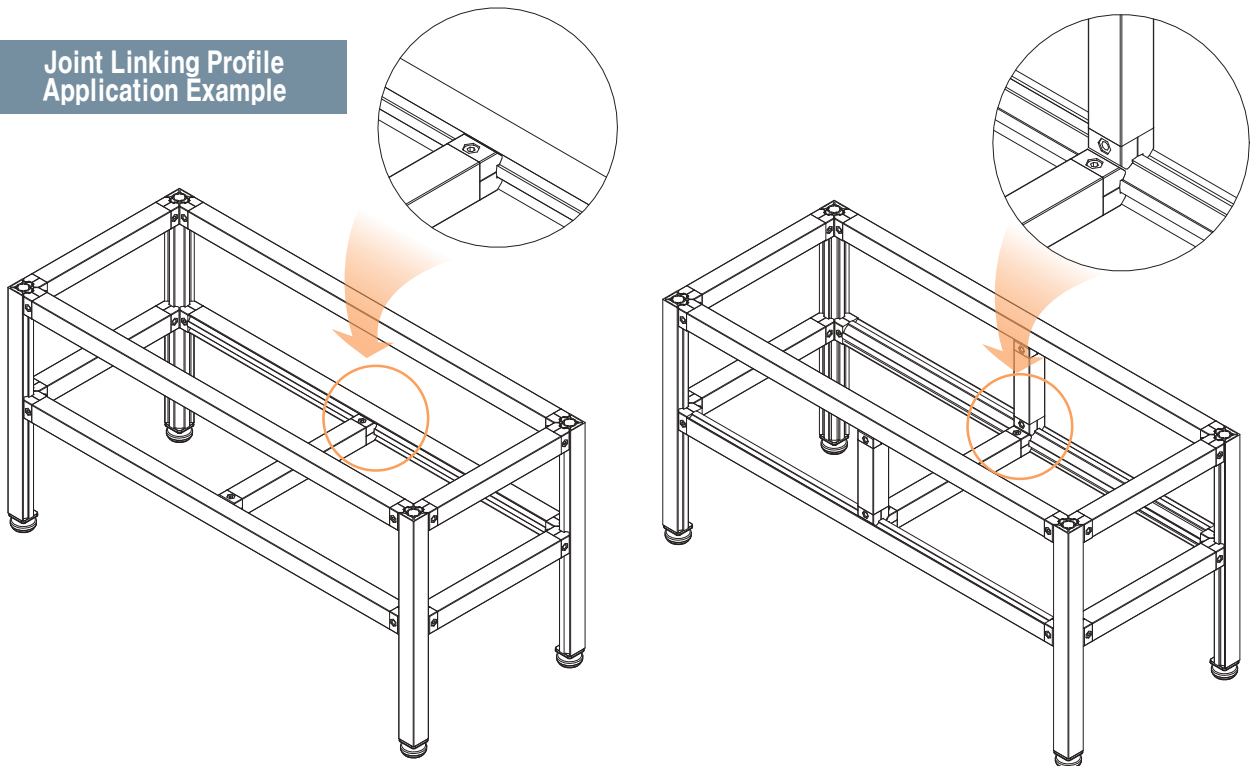

40 X 40 AL PROFILE RACKING SYSTEM

Unit : mm

AST4040A 90° 2-Way T-Groove Profile

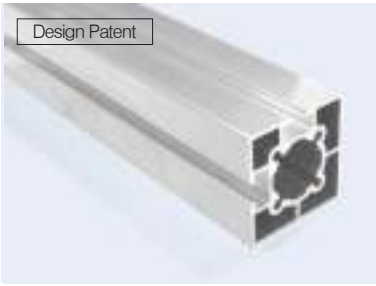

Material	A6063-T5
Weight	1.190 kg/m
Surface Treatment	PE-Coating

* Surface Treatment Option : Anodizing

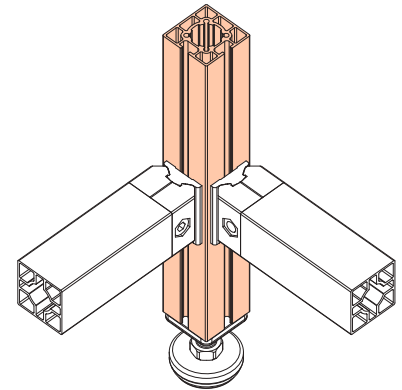
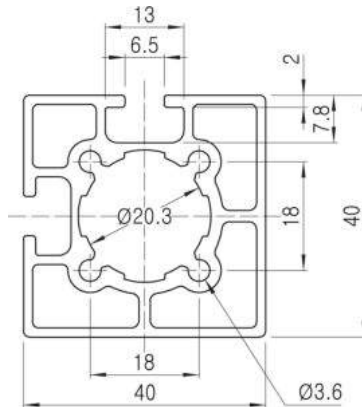

* Insert Nut : IN304~IN306
* Spring Nut : SN304~SN306

AST4040D 4-Way T-Groove Profile

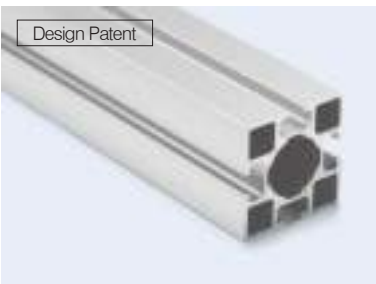

Material	A6063-T5
Weight	1.264 kg/m
Surface Treatment	PE-Coating

* Surface Treatment Option : Anodizing

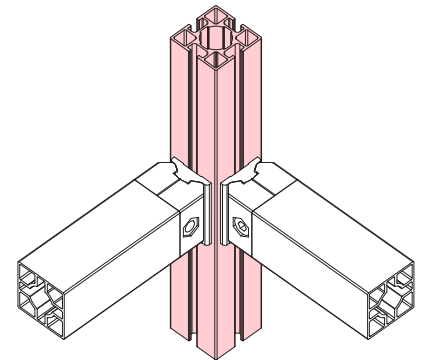
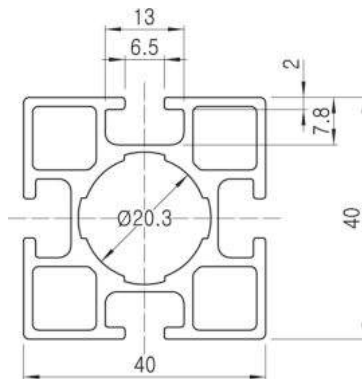

* Insert Nut : IN304~IN306
* Spring Nut : SN304~SN306

T-Groove Profile Application Example

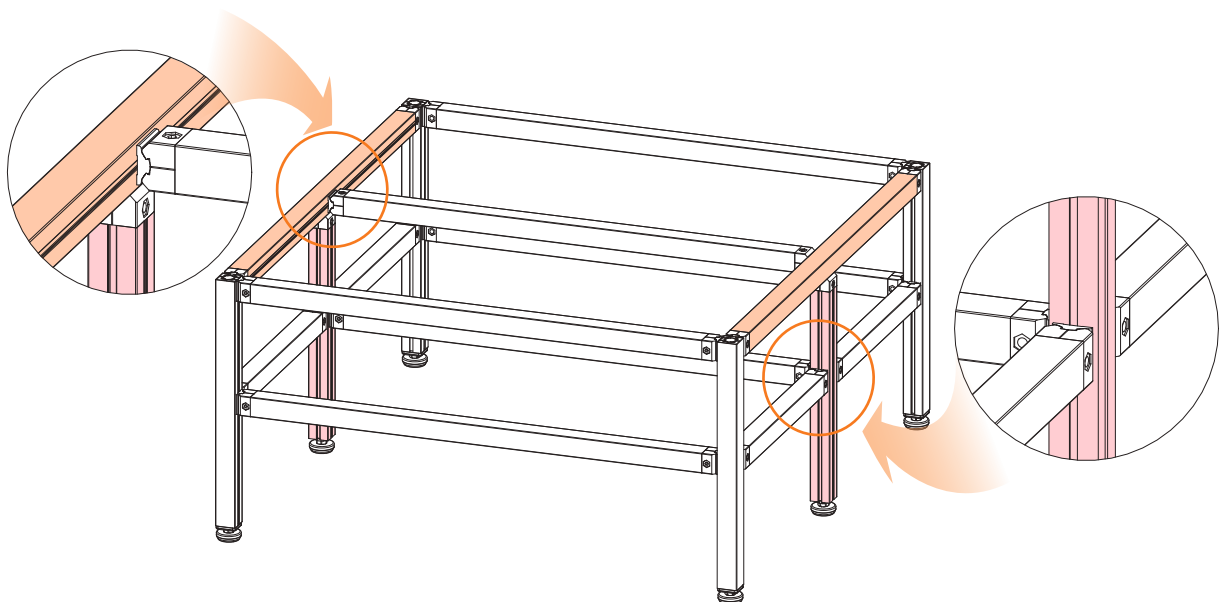

40 X 40 AL PROFILE RACKING SYSTEM

Unit : mm

ASM4040C Combination Profile (3-Way T-Groove, 1-Way Joint Linking)

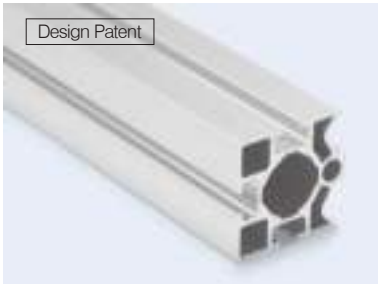

Material	A6063-T5
Weight	1.292 kg/m
Surface Treatment	PE-Coating

* Surface Treatment Option : Anodizing

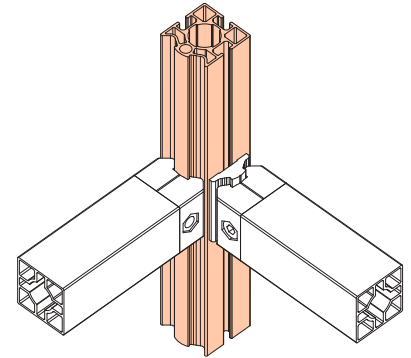
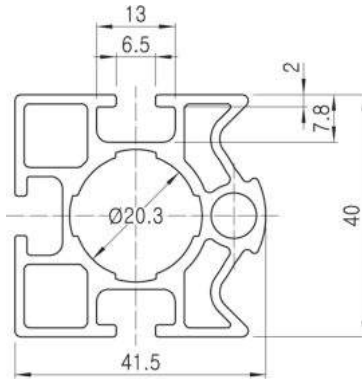

- * Insert Nut : IN304~IN306
- * Spring Nut : SN304~SN306

ASM4040R

Corner Round Combination Profile (1-Way T-Groove, 1-Way Joint Linking)

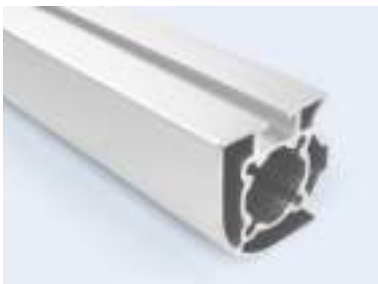

Material	A6063-T5
Weight	1.169 kg/m
Surface Treatment	PE-Coating

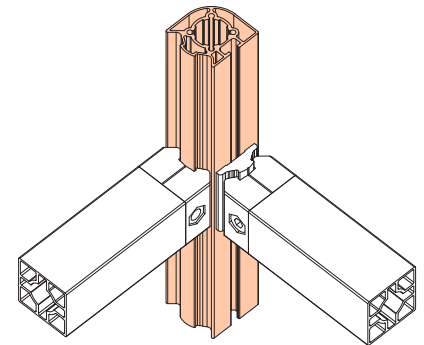
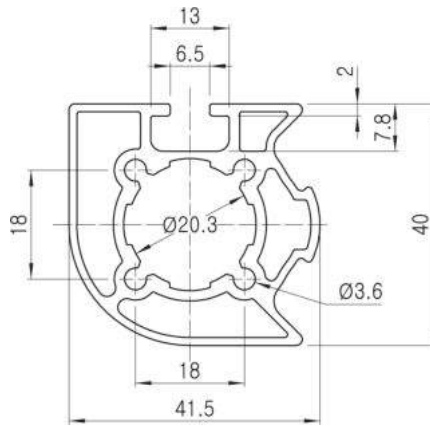

- * Insert Nut : IN304~IN306
- * Spring Nut : SN304~SN306

Combination Profile Application Example

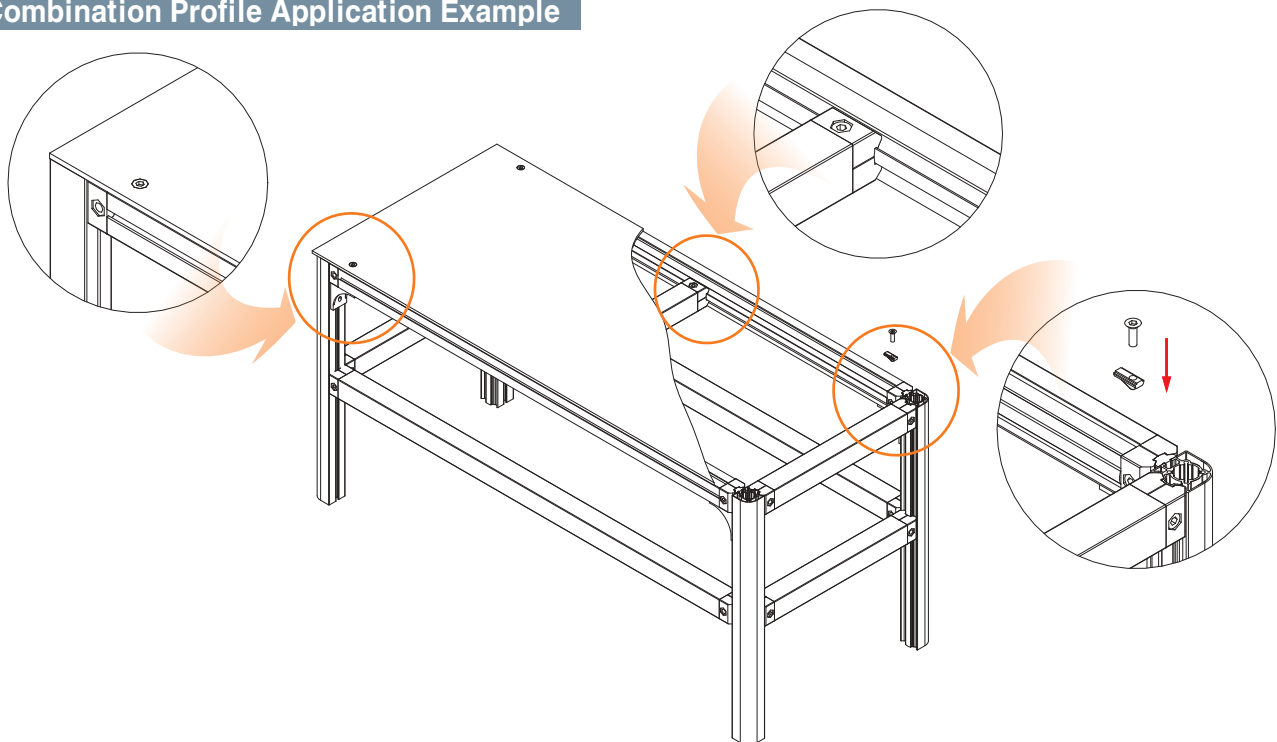

40 X 40 AL PROFILE RACKING SYSTEM

40X40 ALUMINUM JOINTS & ACCESSORIES

D-001

Square Joint for 40x40

Patent Pending



DA-001

- Weight : 0.044kg
- Q'ty/Box : 120pcs

- D-001 : 2EA
- M0830/N08 : 1set
- Weight : 0.108kg
- Q'ty/Box : 60set

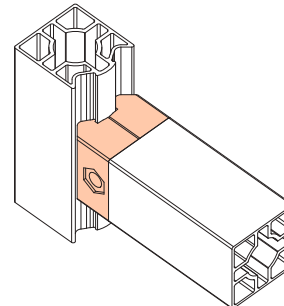
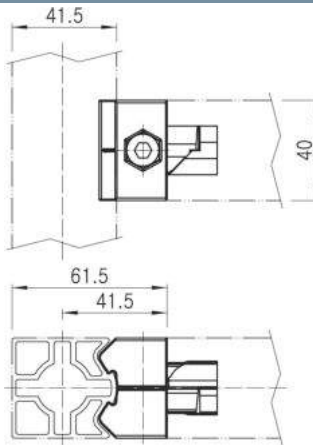

B-50A

Corner Bracket for T-Groove Assembly (M6)



- Weight : 0.034kg
- Q'ty/Box : 100pcs

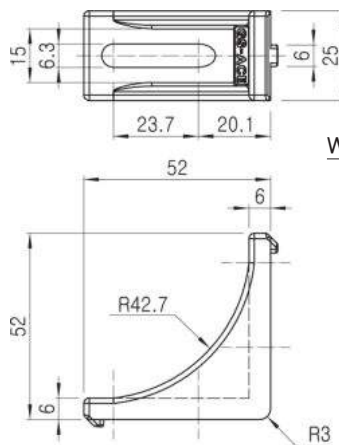

Wrench Bolt (M6*10)

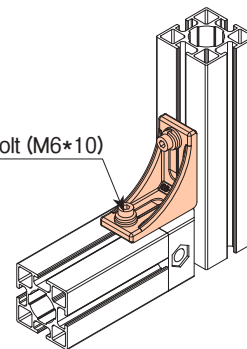

※ Use M6*15 in case of using spring washer & plane washer

B-060A

Corner Bracket for T-Groove Assembly (M6)



- Weight : 0.046kg
- Q'ty/Box : 60pcs

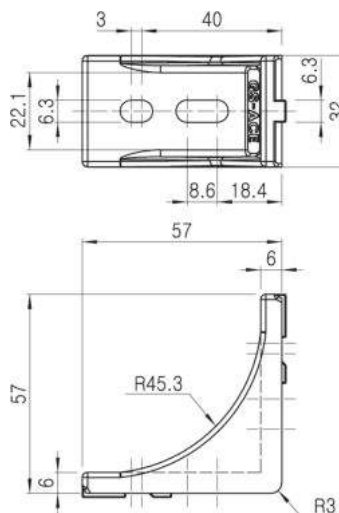

Wrench Bolt (M6*10)

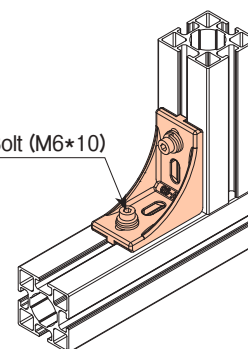

※ Use M6*15 in case of using spring washer & plane washer

40 X 40 AL PROFILE RACKING SYSTEM

BA4040A/B Aluminum Bushing for 40x40



- Weight : 0.027kg
- Q'ty/Box : 200EA

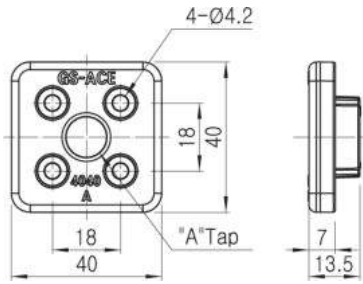

Part No.	"A" Tap	Remark
BA4040A	1/2"-12N	
BA4040B	M12-p1.75	

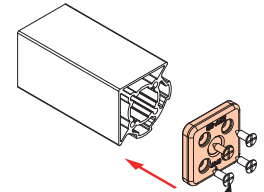

Flat Haded Tapping Screw(FH8x25)



GAP-4040A Inner Cap for 40x40



- Weight : 0.005kg
- Q'ty/Box : 1200pcs

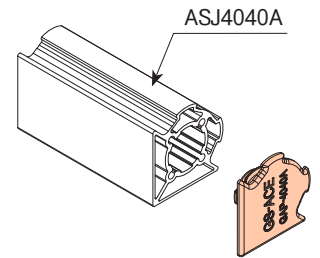
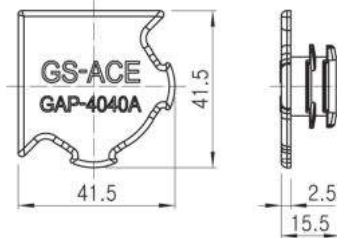

ASJ4040A

GAP-4040D Inner Cap for 40x40



- Weight : 0.005kg
- Q'ty/Box : 1200pcs

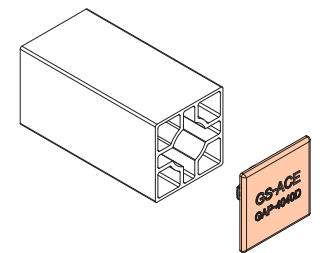
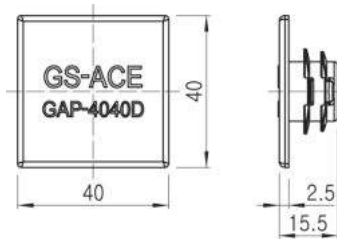

GAP-4040R Inner Cap for 40x40



- Weight : 0.005kg
- Q'ty/Box : 1200pcs

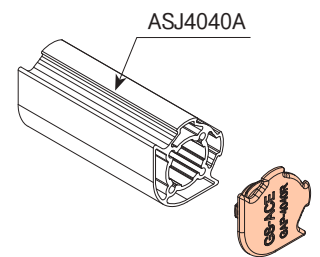
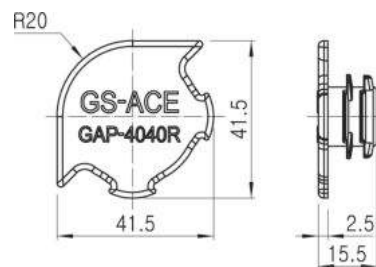

ASJ4040A



40 X 40 AL PROFILE RACKING SYSTEM

45X45 ALUMINUM PROFILE

ASJ4545A 90° 2-Way Joint Linking Profile



Material	A6063-T5
Weight	1.320 kg/m
Surface Treatment	PE-Coating

* Surface Treatment Option : Anodizing

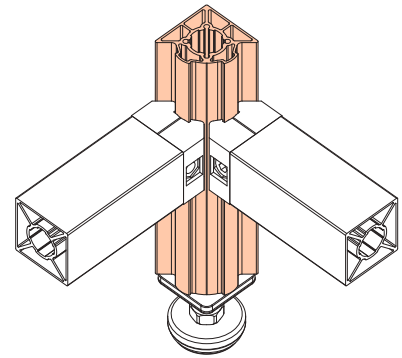
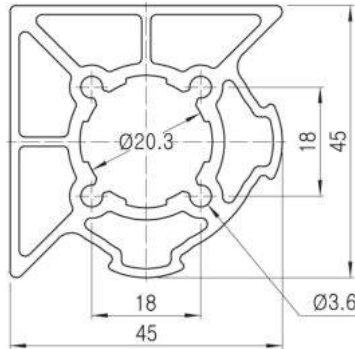

ASJ4545C 1-Way Joint Linking Profile

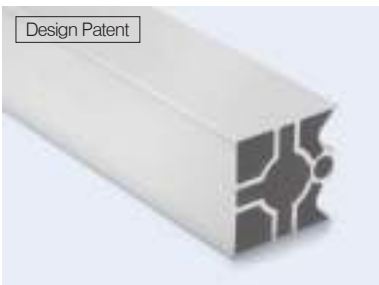

Material	A6063-T5
Weight	1.412 kg/m
Surface Treatment	PE-Coating

* Surface Treatment Option : Anodizing

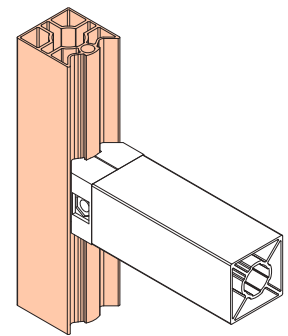
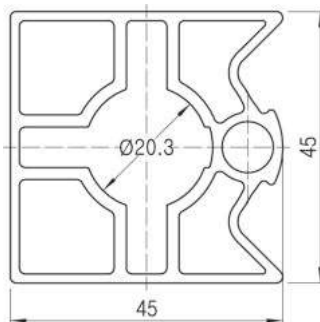

ASJ4545D Profile to Prevent Foreign Particles from Entering

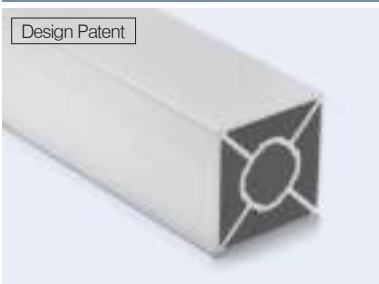

Material	A6063-T5
Weight	1.495 kg/m
Surface Treatment	PE-Coating

* Surface Treatment Option : Anodizing

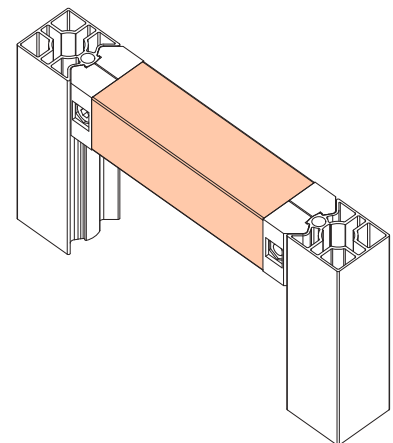
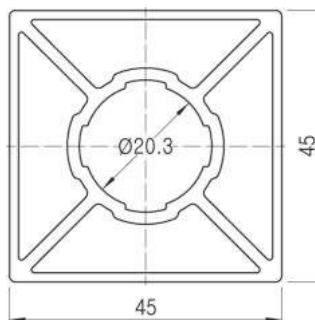

45 X 45 AL PROFILE RACKING SYSTEM

AST4545A 90° 2-Way T-Groove Profile

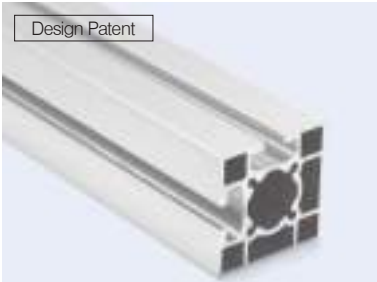

Material	A6063-T5
Weight	1.513 kg/m
Surface Treatment	PE-Coating

* Surface Treatment Option : Anodizing

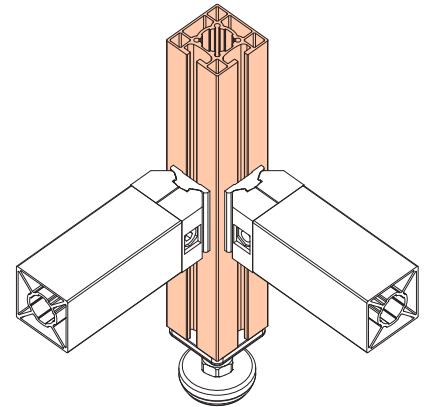
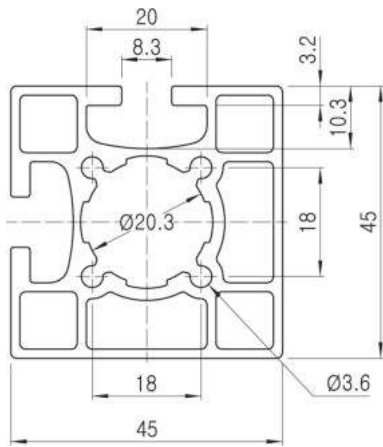

* Insert Nut : IN404~IN408
* Spring Nut : SN404~SN408

AST4545D 4-Way T-Groove Profile

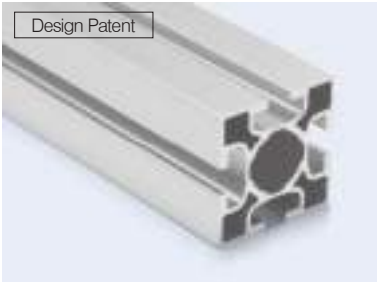

Material	A6063-T5
Weight	1.607 kg/m
Surface Treatment	PE-Coating

* Surface Treatment Option : Anodizing

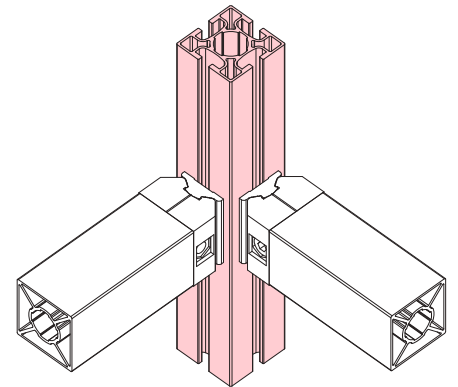
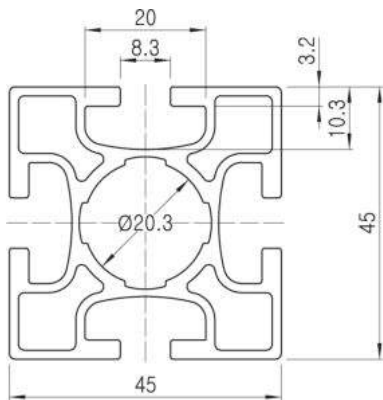

* Insert Nut : IN404~IN408
* Spring Nut : SN404~SN408

ASM4545C Combination Profile (3-Way T-Groove, 1-Way Joint Linking)

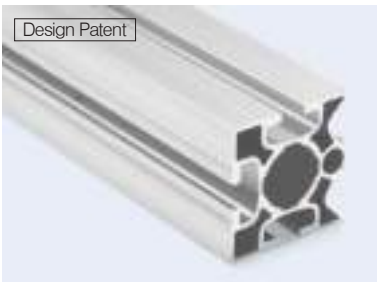

Material	A6063-T5
Weight	1.595 kg/m
Surface Treatment	PE-Coating

* Surface Treatment Option : Anodizing

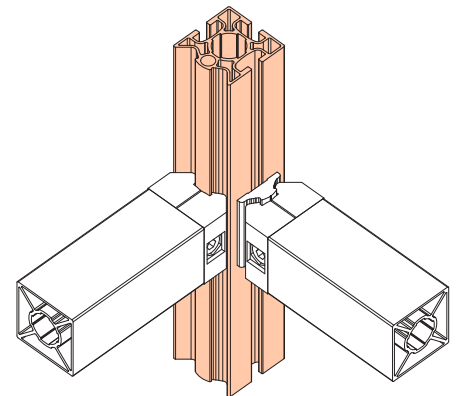
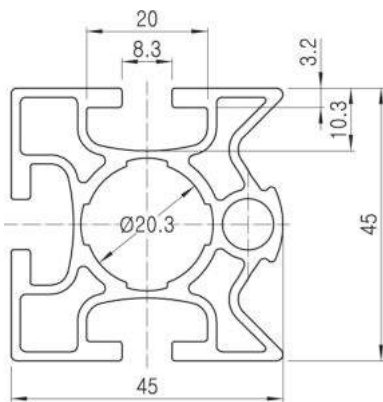

* Insert Nut : IN404~IN408
* Spring Nut : SN404~SN408

45 X 45 AL PROFILE RACKING SYSTEM

45X45 ALUMINUM JOINTS & ACCESSORIES

E-001

Square Joint for 45x45

Patent Pending



EA-001

- Weight : 0.050kg
- Q'ty/Box : 100EA

- E-001 : 2EA
- M0830/N08 : 1set
- Weight : 0.120kg
- Q'ty/Box : 50set

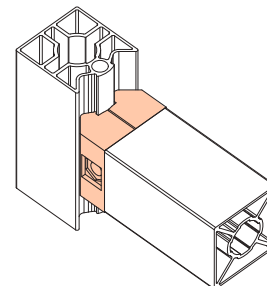
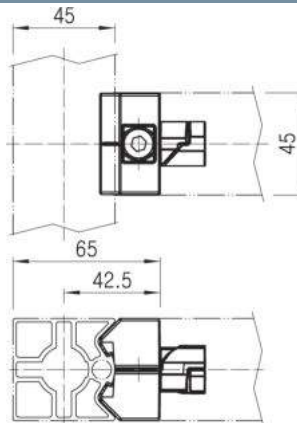

B-080A

Corner Bracket for T-Groove Assembly (M8)



- Weight : 0.062kg
- Q'ty/Box : 40pcs

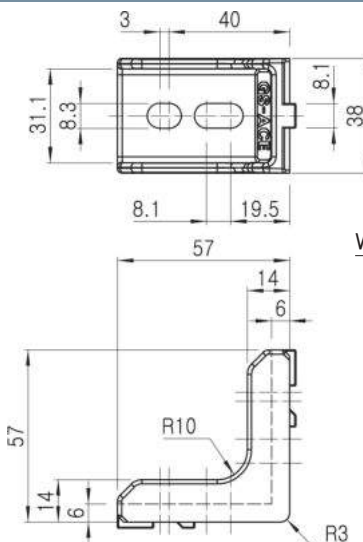

Wrench Bolt (M8*15)

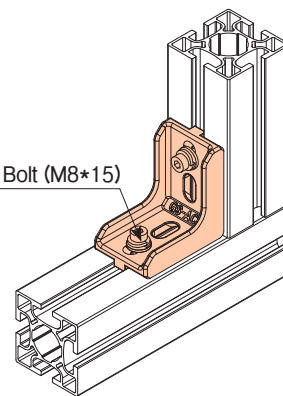

BA4545A/B

Aluminum Bushing for 45x45



- Weight : 0.034kg
- Q'ty/Box : 200EA

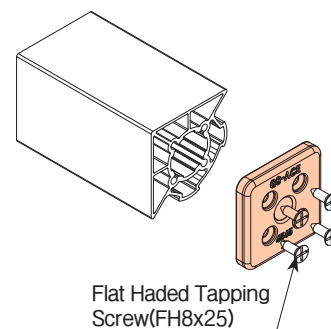
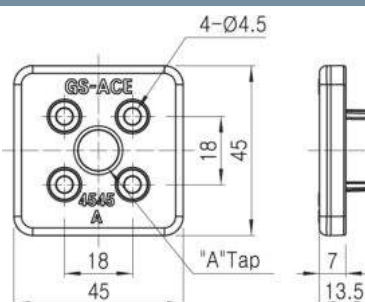

Flat Haded Tapping Screw(FH8x25)

Part No.	"A" Tap	Remark
BA4545A	1/2"-12N	
BA4545B	M12-p1.75	

GAP-4545D

Inner Cap for 45x45



- Weight : 0.006kg
- Q'ty/Box : 1200EA

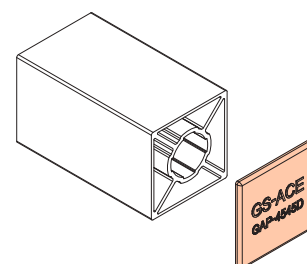
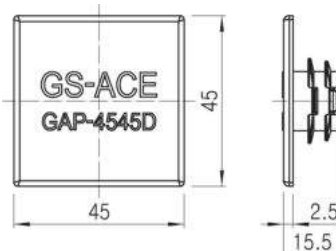

ROLLER TRACK SYSTEM



- ROLLER TRACKS
 - STANDARD ROLLER TRACK
 - SILENT ROLLER TRACK
 - STS COVERED ROLLER TRACK
 - UNIVERSAL ROLLER TRACK
- ROLLER TRACK CAP
- MOUNTING BRACKETS
- SLIDE PIPE MOUNTING BRACKETS
- BOX GUIDE
- BOX GUIDE CAP
- BOX STOPPER

ROLLER TRACKS

ROLLER TRACK NUMBERING SYSTEM

Unit : mm

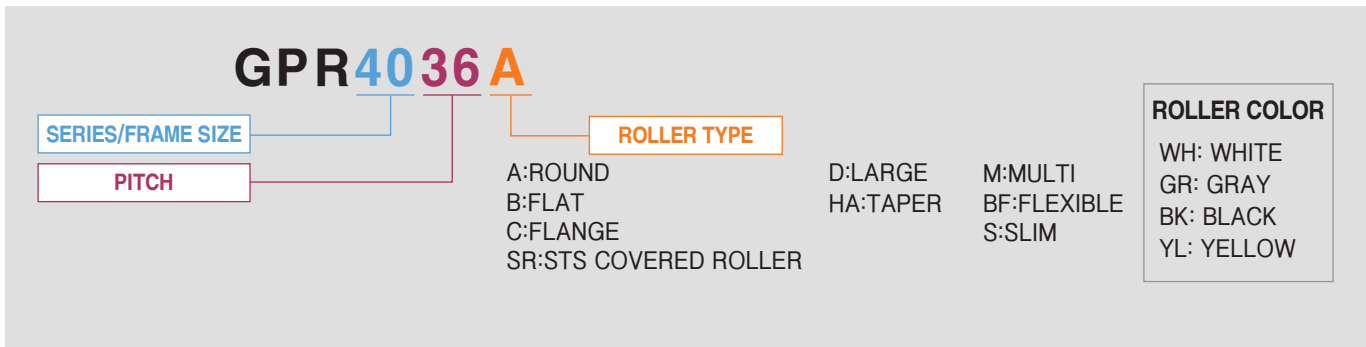

SPECIFICATION

STANDARD ROLLER TRACK

Series	Part No.	Body Material (mm)	Load Capacity (Kg-f)	Roller Diameter (mm)	Shaft Diameter (mm)	Roller Pitch (mm)	Slope >()°	Roller Color				ESD		Standard Length
								WH	GR	BK	YL	BK	GR	
35 Series	GP3533B	GI	100	Ø28	Ø3	33.33	2.5°	○	○	○	○	○	○	3MT/4MT
40 Series	GP4035BS	GI	100	Ø30	Ø3	35	2.0°	○	○	○	○	○	○	3MT/4MT
	GP4036A							○	○	○	○	○		
	GP4036B							○	○	○	○	○		
	GP4040A							○	○	○	○	○		
	GP4040B							○	○	○	○	○		
	GP4050C							○	○	○	○	○		
	GP4050D							○	○	○	○	○		
	GP4025M							○	○	○	○	○		
60 Series	GP6016S	GI	100	Ø15	Ø4	16.67	2.5°	○	○	○	○	○	3MT/4MT	
	GP6033B		150	Ø30		33.33		○	○	○	○			
	GP6033HA		○	○		○		○	○					
85 Series	GP8525M	GI	300	Ø34	Ø5	25	2.5°	○	○	○	○	○	3MT/4MT	
	GP8543B			Ø40		43		○	○	○	○			

SILENT ROLLER TRACK

Series	Part No.	Body Material (mm)	Load Capacity (Kg-f)	Roller Diameter (mm)	Shaft Diameter (mm)	Roller Pitch (mm)	Slope >()°	Roller Color				ESD		Standard Length
								WH	GR	BK	YL	BK	GR	
25 Series	GPR2528A	AL	60	Ø25	Ø3	28.57	1.5°	○	○	○	○	○	○	3MT/4MT
40 Series	GPR4040A	GI/AL	150	Ø34	Ø4	40	2.0°	○	○	○	○	○	○	3MT/4MT
	GPR4040B							○	○	○	○	○		
	GPR4055C							○	○	○	○	○		
	GPRG4040B	AL	Ø34	40	○	○	○	○	○					
60 Series	GPR6016S	GI/AL	100	Ø15	Ø4	16.67	2.5°	○	○	○	○	○	3MT/4MT	
	GPR6033B		150	Ø30		33.33		○	○	○	○			
	GPR6033HA		150	○		○		○	○	○				
85 Series	GPR8523S	GI/AL	200	Ø20.5	Ø3.5	22.5	1.5°	○	○	○	○	○	4MT	
	GPR8545B		300	Ø40		45		○	○	○	○			
	GPR8545HA		○	○		○		○	○	○				
100 Series	GPR1021BFS	AL	250	Ø17.6	Ø5	21	-	○	○	○	○	○	2MT/3MT	

ROLLER TRACKS

Unit : mm

STS COVERED ROLLER TRACK

Series	Part No.	Body Material (mm)	Load Capacity (Kg-f)	Roller Diameter (mm)	Shaft Diameter (mm)	Roller Pitch (mm)	Slope >()°	Roller Color				ESD		Standard Length
								WH	GR	BK	YL	BK	GR	
40 Series	GPR4040SR	GI/AL	150	Ø34	Ø4	40	2.0°		○					3MT/4MT
85 Series	GPR8523SR		300	Ø20.6	Ø3.5	22.5	1.5°		○					2MT
	GPR8545SR			Ø43		45			○					

UNIVERSAL ROLLER TRACK

Series	Part No.	Body Material (mm)	Load Capacity (Kg-f)	Roller Diameter (mm)	Shaft Diameter (mm)	Roller Pitch (mm)	Slope >()°	Roller Color				ESD		Standard Length
								WH	GR	BK	YL	BK	GR	
40 Series	UR4050	AL	100	Ø43	Ø4	50	2.5°		○			○		3MT
60 Series	UR6067		200	Ø60	Ø5	66.7	3.0°		○			○		2MT

CHOICE OF THE ROLLER TYPE

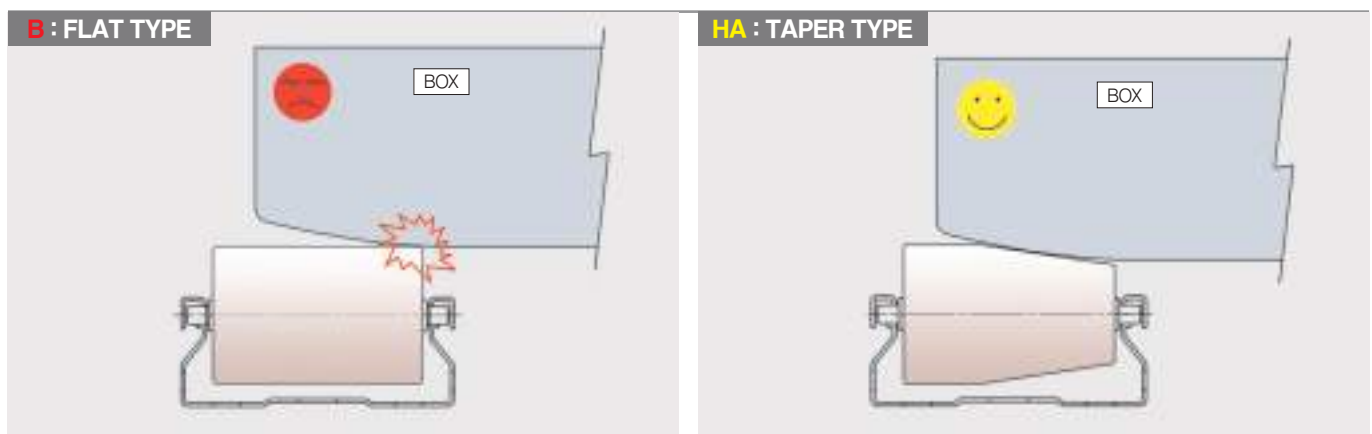

※ Old box with the bent bottom will not be rolled over B Type

※ Old box with the bent bottom will be well-rolled over HA Type

ROLLER TRACKS

STANDARD ROLLER TRACK

Unit : mm

GP-3533B Pitch : 33



Material	Body : GI
	Roller : PE
Q'ty/Bundle	10ea

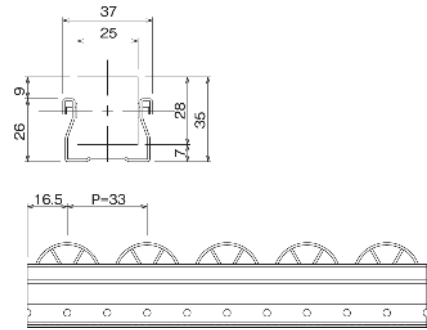

GP-4035BS Pitch : 35



Material	Body : GI
	Roller : PE
Q'ty/Bundle	10ea

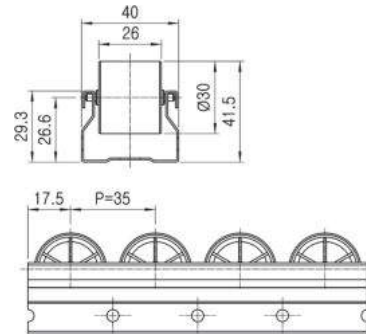

GP-4036A Pitch: 36



Material	Body : GI
	Roller : PE
Q'ty/Bundle	10ea

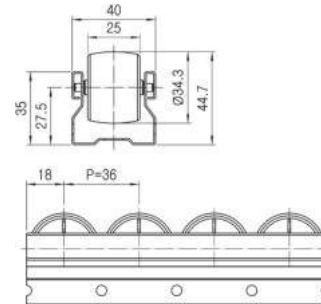

GP-4036B Pitch: 36



Material	Body : GI
	Roller : PE
Q'ty/Bundle	10ea

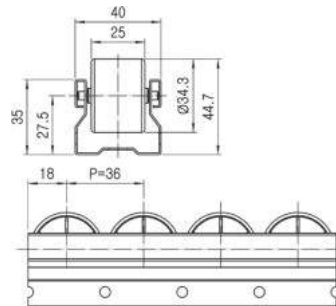

GP-4040A Pitch: 40



Material	Body : GI
	Roller : PE
Q'ty/Bundle	10ea

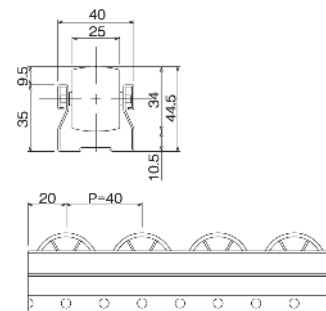

ROLLER TRACKS

Unit : mm

GP-4040B Pitch: 40



Material	Body : GI
	Roller : PE
Q'ty/Bundle	10ea

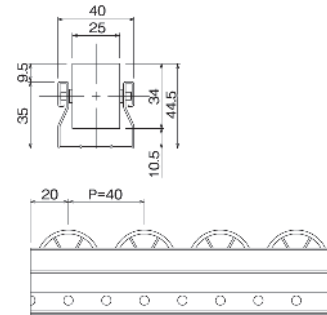

GP-4050C Pitch: 50



Material	Body : GI
	Roller : PE
Q'ty/Bundle	10ea

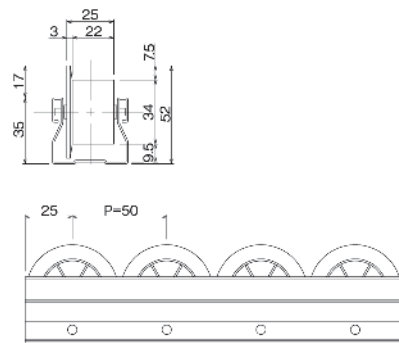

GP-4050D Pitch: 50



Material	Body : GI
	Roller : PE
Q'ty/Bundle	10ea

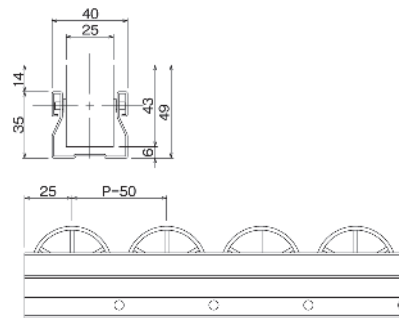

GP4025M Pitch: 25



Material	Body : GI
	Roller : PE
Q'ty/Bundle	10ea

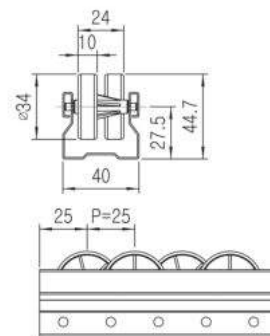

GP6016S Pitch: 16



Material	Body : GI
	Roller : PE
Q'ty/Bundle	10ea

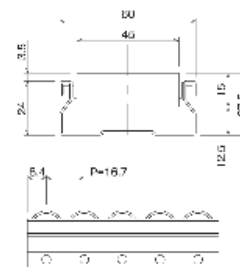

ROLLER TRACKS

Unit : mm

GP6033B Pitch: 33



Material	Body : GI
	Roller : PE
Q'ty/Bundle	10ea

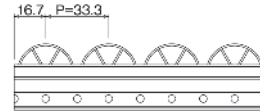
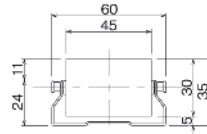

GP6033HA Pitch: 33



Material	Body : GI
	Roller : PE
Q'ty/Bundle	6ea

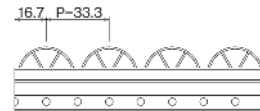
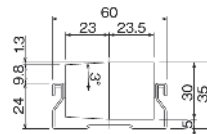

GP8525M Pitch: 25



Material	Body : GI
	Roller : PE
Q'ty/Bundle	4ea

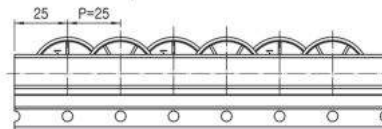
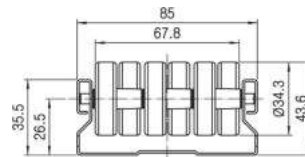

GP8543B Pitch: 43



Material	Body : GI
	Roller : PE
Q'ty/Bundle	4ea

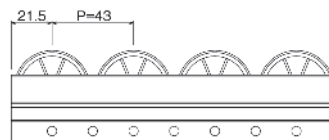
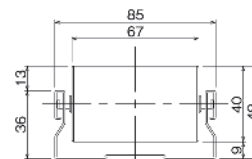

ROLLER TRACKS

SILENT ROLLER TRACK

Unit : mm

GPR2528A-AL Silent Roller, Pitch: 28,6

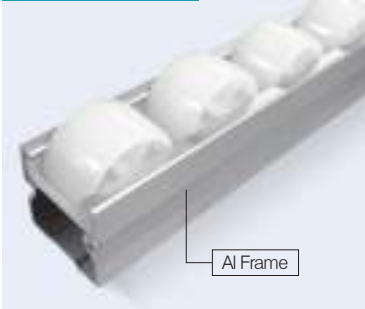

Al Frame

Material	Body : Aluminum
	Roller : PE
Q'ty/Bundle	14ea

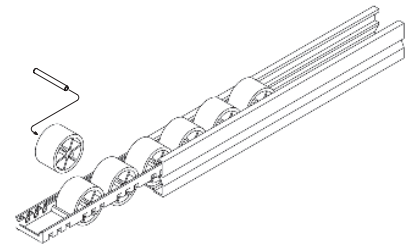
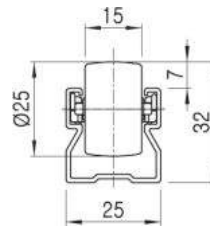

GPR4040A/B-GI Silent Roller, Pitch: 40



Material	Body : GI
	Roller : PE
Q'ty/Bundle	10ea

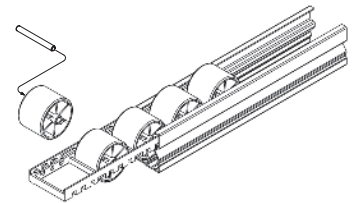
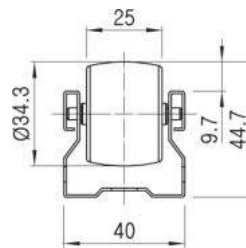

GPR4040A/B-AL Silent Roller, Pitch: 40



Al Frame

Material	Body : Aluminum
	Roller : PE
Q'ty/Bundle	10ea

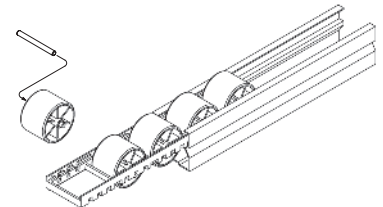
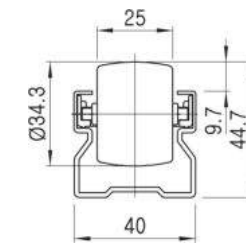

GPR4055C-GI Silent Roller, Pitch: 55



Material	Body : GI
	Roller : PE
Q'ty/Bundle	10ea

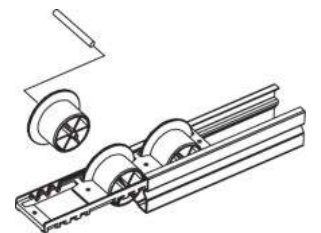
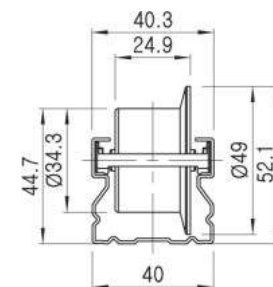

GPR4055C-AL Silent Roller, Pitch: 55



Material	Body : Aluminum
	Roller : PE
Q'ty/Bundle	10ea

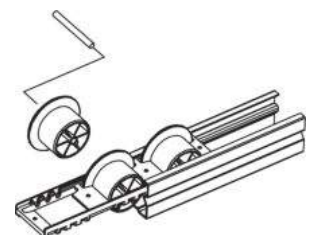
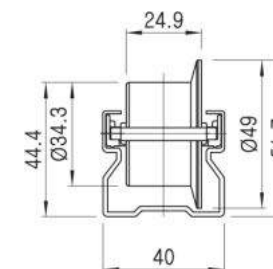

ROLLER TRACKS

Unit : mm

GPRG4040B Guide Type Roller Track, Pitch : 40

Patent Pending



Material	Body : Aluminum
	Roller : PE
Q'ty/Bundle	4pcs

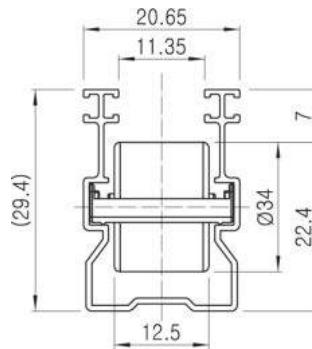

ACY-317A Groove Cover



Material	Silicon
Weight	0.064kg/m

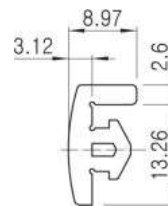

GPRG4040B Application Example

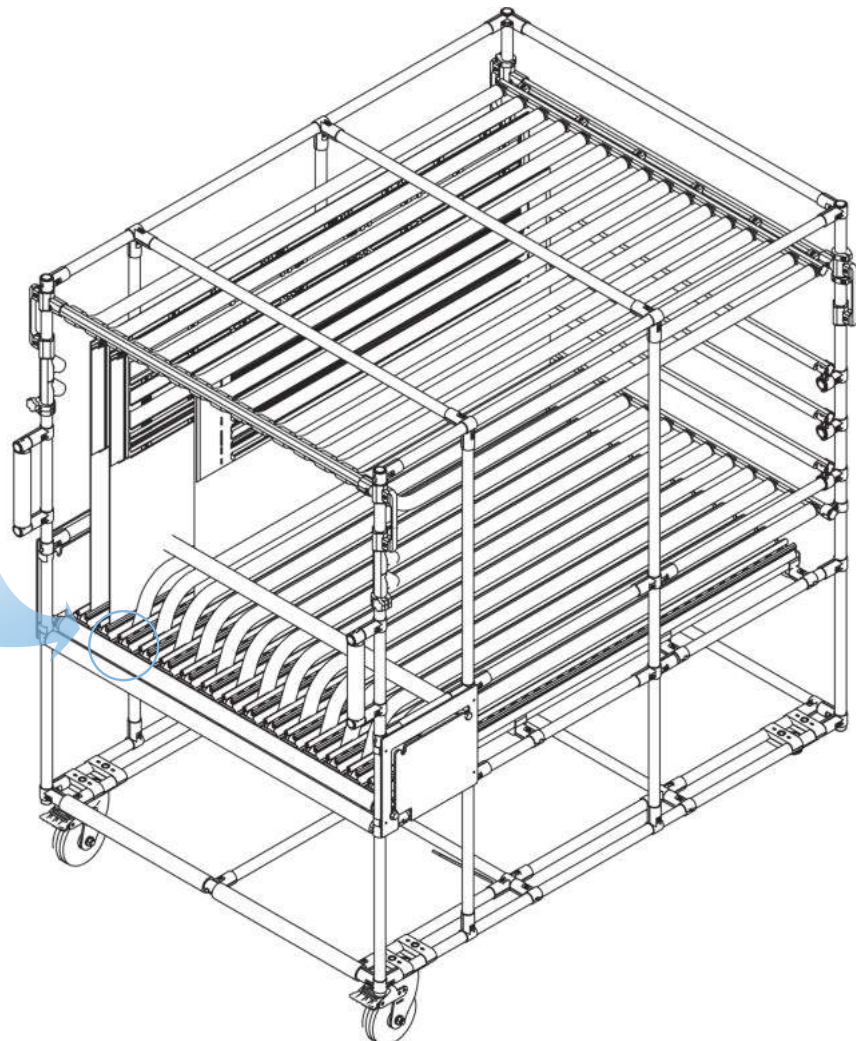
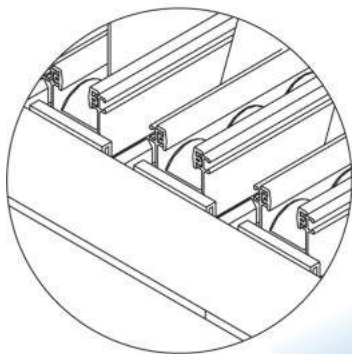

※ Used for loading and moving Display Panel Silicon Groove Cover(ACY-317A) can be attached to protect loaded products

ROLLER TRACKS

Unit : mm

GPR6016S-GI Silent Roller, Pitch: 16



Material	Body : GI
	Roller : PE
Q'ty/Bundle	6ea

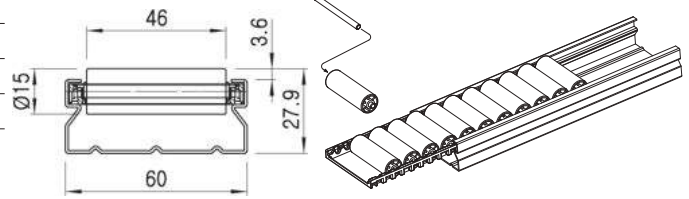

GPR6016S-AL Silent Roller, Pitch: 16



Material	Body : Aluminum
	Roller : PE
Q'ty/Bundle	6ea

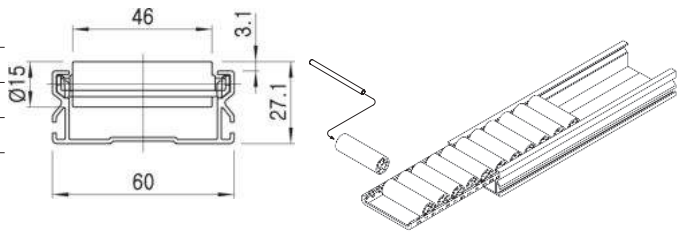

GPR6033B-GI Silent Roller, Pitch: 33



Material	Body : Aluminum
	Roller : PE
Q'ty/Bundle	6ea

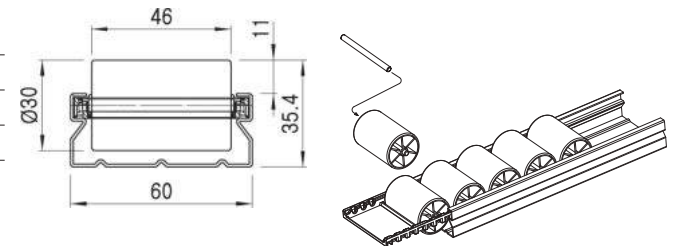

GPR6033B-AL Silent Roller, Pitch: 33



Material	Body : Aluminum
	Roller : PE
Q'ty/Bundle	6ea

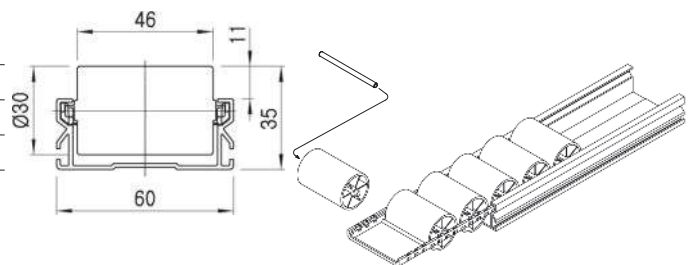

GPR6033HA-GI Silent Roller, Pitch: 33



Material	Body : GI
	Roller : PE
Q'ty/Bundle	6ea

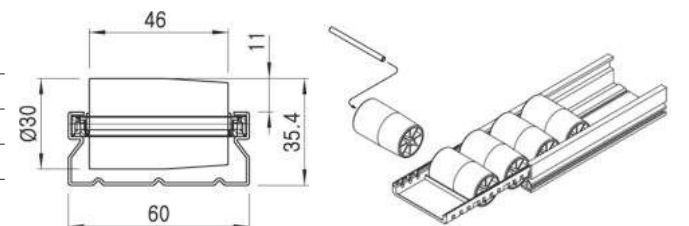

ROLLER TRACKS

Unit : mm

GPR6033HA-AL Silent Roller, Pitch: 33



Material	Body : Aluminum
	Roller : PE
Q'ty/Bundle	6ea

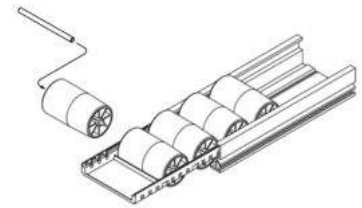
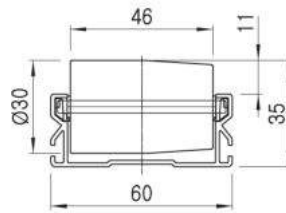

GPR8523S-GI Silent Roller, Pitch: 22.5



Material	Body : GI
	Roller : PE
Q'ty/Bundle	4ea

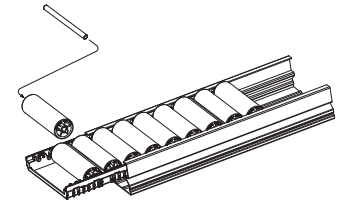
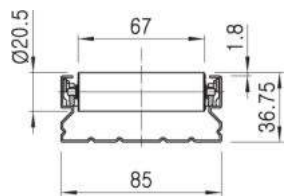

GPR8523S-AL Silent Roller, Pitch: 22.5



Material	Body : Aluminum
	Roller : PE
Q'ty/Bundle	4ea

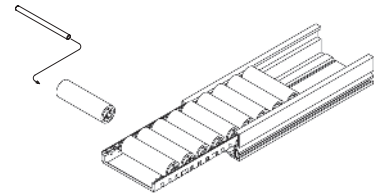
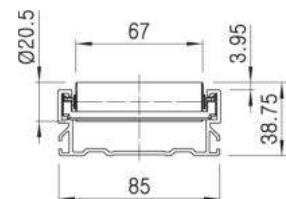

GPR8545B-GI Silent Roller, Pitch: 45



Material	Body : GI
	Roller : PE
Q'ty/Bundle	4ea

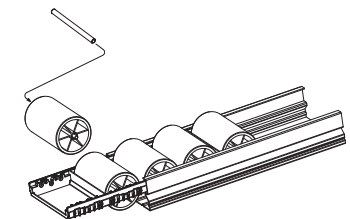
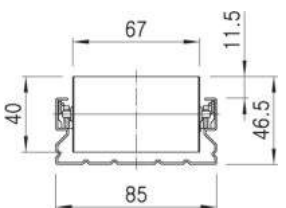

GPR8545B-AL Silent Roller, Pitch: 45

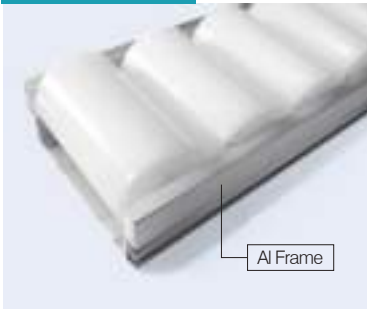

Material	Body : Aluminum
	Roller : PE
Q'ty/Bundle	4ea

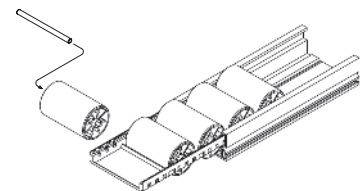
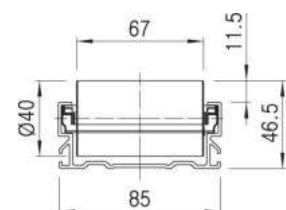

ROLLER TRACKS

Unit : mm

GPR8545HA-GI Silent Roller, Pitch: 45



Material	Body : GI
	Roller : PE
Q'ty/Bundle	4ea

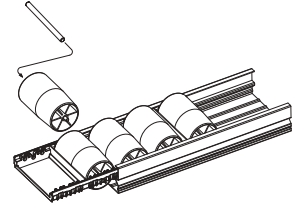
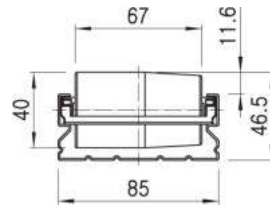

GPR8545HA-AL Silent Roller, Pitch: 45

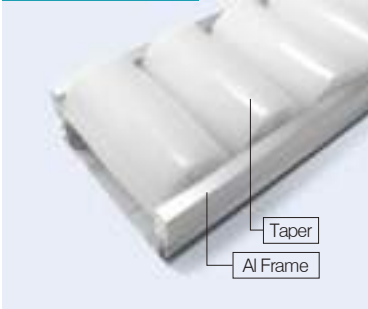

Material	Body : Aluminum
	Roller : PE
Q'ty/Bundle	4ea

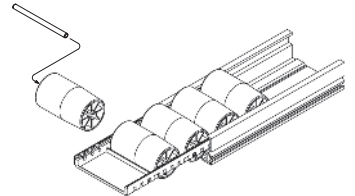
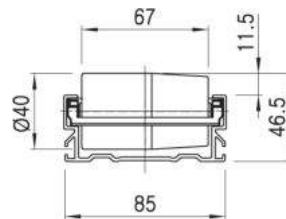

GPR1021BFS-AL Silent Roller, Pitch: 21

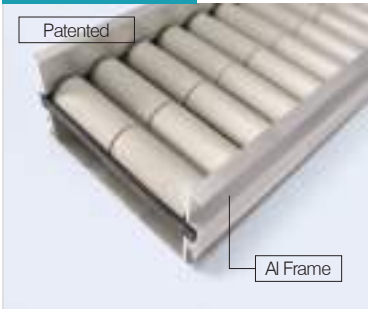

Material	Body : Aluminum
	Roller : Urethane
Q'ty/Bundle	4ea

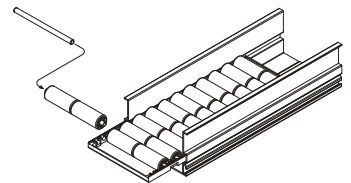
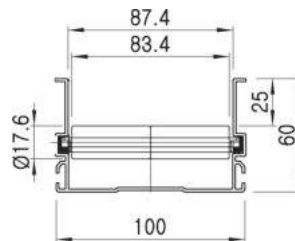

ROLLER TRACKS

STS COVERED ROLLER TRACK

Unit : mm

GPR4040SR-GI STS Covered Roller, Pitch: 40



Material	Body : GI
	Roller : STS+PE
Q'ty/Bundle	10ea

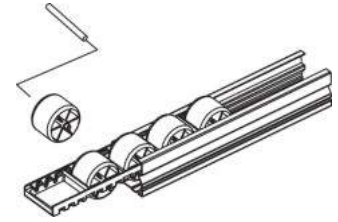
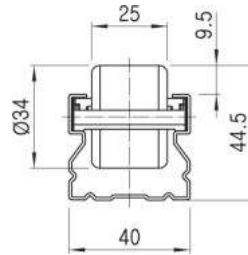

GPR4040SR-AL STS Covered Roller, Pitch: 40



Material	Body : Aluminum
	Roller : STS+PE
Q'ty/Bundle	10ea

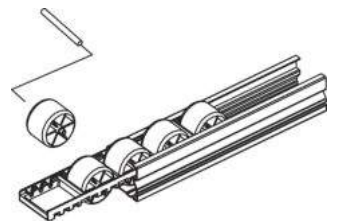
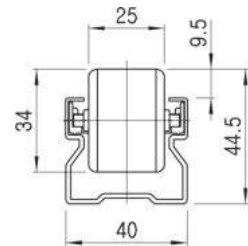

GPR8523SR-GI STS Covered Roller, Pitch: 23



Material	Body : GI
	Roller : STS+PE
Q'ty/Bundle	4ea

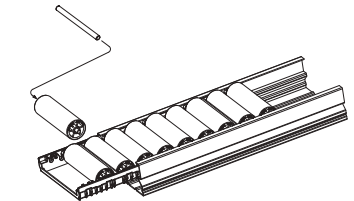
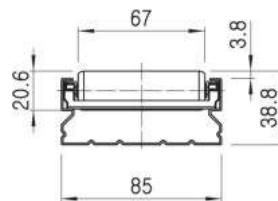

GPR8523SR-AL STS Covered Roller, Pitch: 23



Material	Body : Aluminum
	Roller : STS+PE
Q'ty/Bundle	4ea

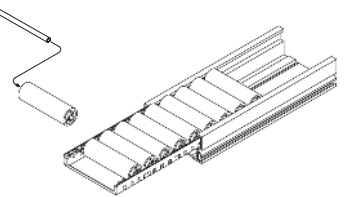
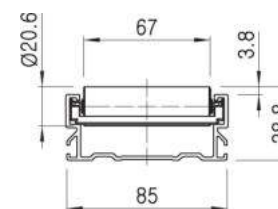

GPR8545SR-GI STS Covered Roller, Pitch: 45



Material	Body : GI
	Roller : STS+PE
Q'ty/Bundle	4ea

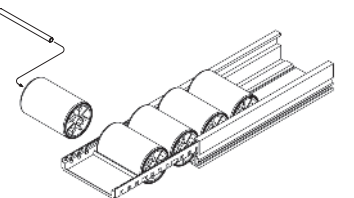
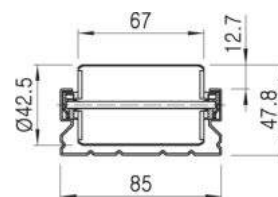

GPR8545SR-AL STS Covered Roller, Pitch: 45



Material	Body : Aluminum
	Roller : STS+ PE
Q'ty/Bundle	4ea

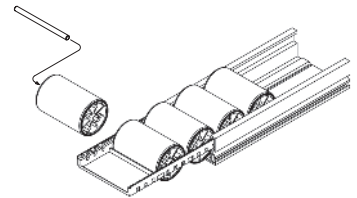
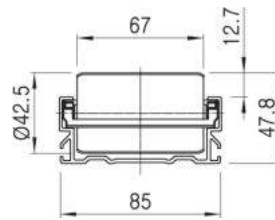

- STS COVERED ROLLER TRACK FEACTURES -

1. Excellent durability of abrasion

- Surface of Roller is Stainless(STS) material

2. No Dust

- No Dust of Roller in comparison with Plastic Roller caused by friction with box

3. Strong to shock

- Surface of Roller is Stainless(STS) material

4. No surface contamination

- Possible to keep clean condition by getting rid of stain or dirty things in Roller Surface

ROLLER TRACKS

UNIVERSAL ROLLER TRACK

Unit : mm

UR4050-AL Universal Roller, Pitch: 50



Material	Body : Aluminum
	Roller : Acetal
Q'ty/Bundle	6ea

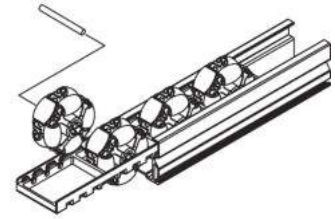
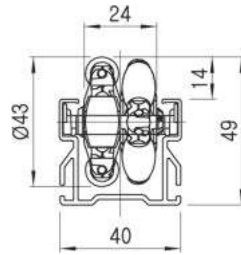

UR6067-AL Universal Roller, Pitch:67



Material	Body : Aluminum
	Roller : Acetal
Q'ty/Bundle	4ea

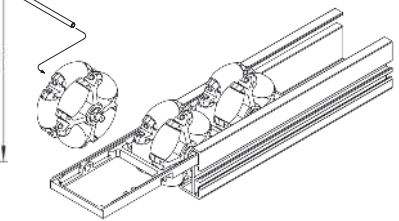
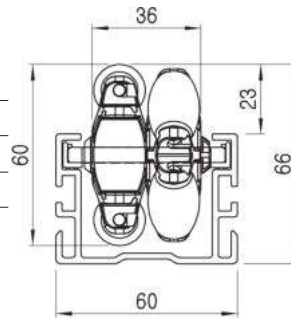

ROLLER TRACKS

Unit : mm

PR-01 Pipe Roller - L



Material	PE
Weight	0.031kg
Q'ty/Box	150pcs

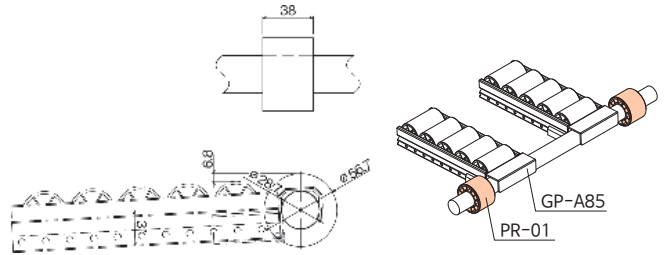

PR-02 Pipe Roller - S



Material	PE
Weight	0.022kg
Q'ty/Box	210pcs

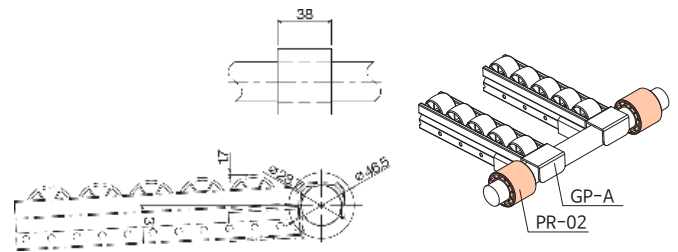

SR-40 Stop Roller



Material	PE
Weight	0.012kg
Q'ty/Box	450pcs

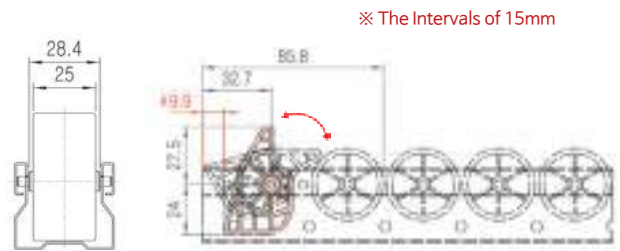

SR-60A Stop Roller



Material	Aluminum
Weight	0.046kg
Q'ty/Box	80pcs

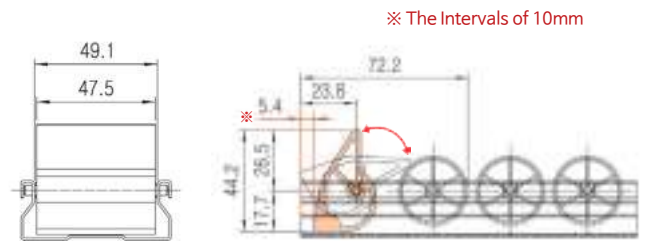

SR-85A Stop Roller



Material	Aluminum
Weight	0.078kg
Q'ty/Box	40pcs

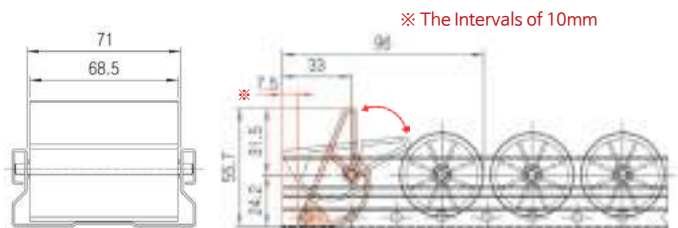

<APPLICATION EXAMPLE OF STOP ROLLER>

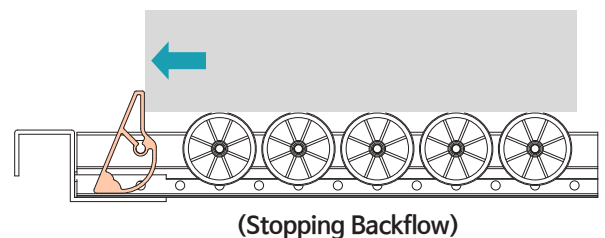
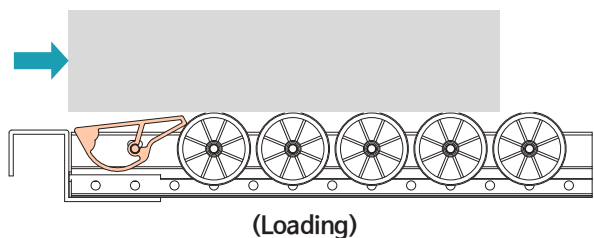

ROLLER TRACKS

Unit : mm

DR-40R Decelerating Roller



Patented

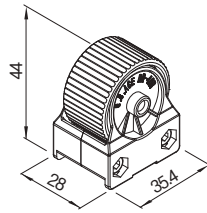

Material	TPU
Weight	0.035kg
Q'ty/Box	120pcs

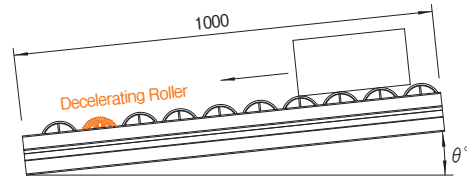

Roller Q'ty	Max. Box Brake Weight per Slope					Remark
	$\theta = 1.5^\circ$	$\theta = 2.0^\circ$	$\theta = 2.5^\circ$	$\theta = 3.0^\circ$	$\theta = 3.5^\circ$	
1set(2ea)	32Kg	25Kg	6 Kg	4 Kg	2.5 Kg	Roller Load = 1.4Kgf/ea
2set(4ea)	-	32Kg	12Kg	9 Kg	5 Kg	

ACA-308B Decelerator

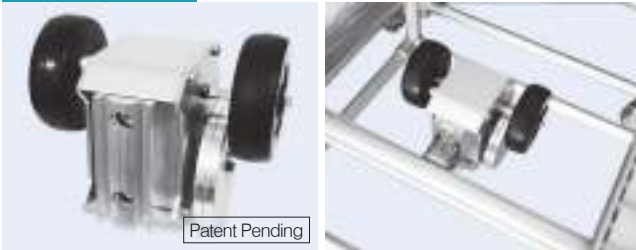

Patent Pending

- 제동범위 : 10Kgf
- Q'ty/Box : 6set

※ ACA-308B is sold basically

PART NO.	ACA-308A	ACA-308B	ACA-308C
Weight Size	∅ 50	∅ 60	∅ 70
Weight(g/Set)	794g	864g	940g
Torque (gf. cm)	160~180gf.cm	280gf.cm	380~400gf.cm

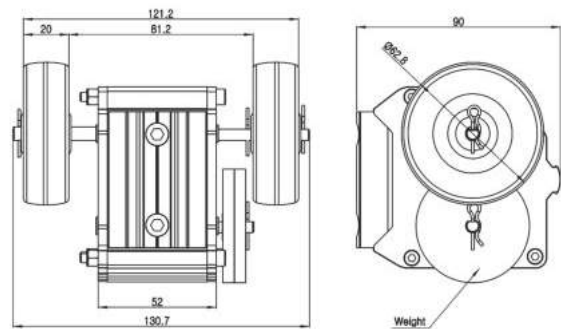

※ Sold separately

W-50	W-60	W-70
∅ 50 (75g)	∅ 60 (110g)	∅ 70 (148g)

APPLICATIONS OF DECELERATOR

STS & Coated Pipe (∅28)



G-6BS

Aluminum Pipe

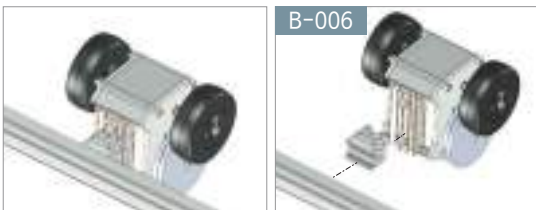

B-006

STS & Coated Pipe (∅28)

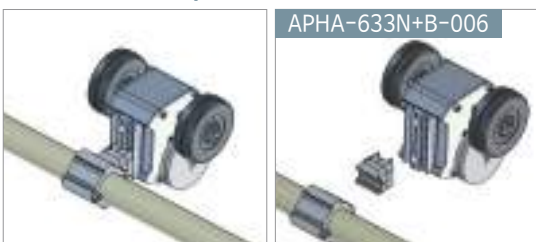

APHA-633N+B-006

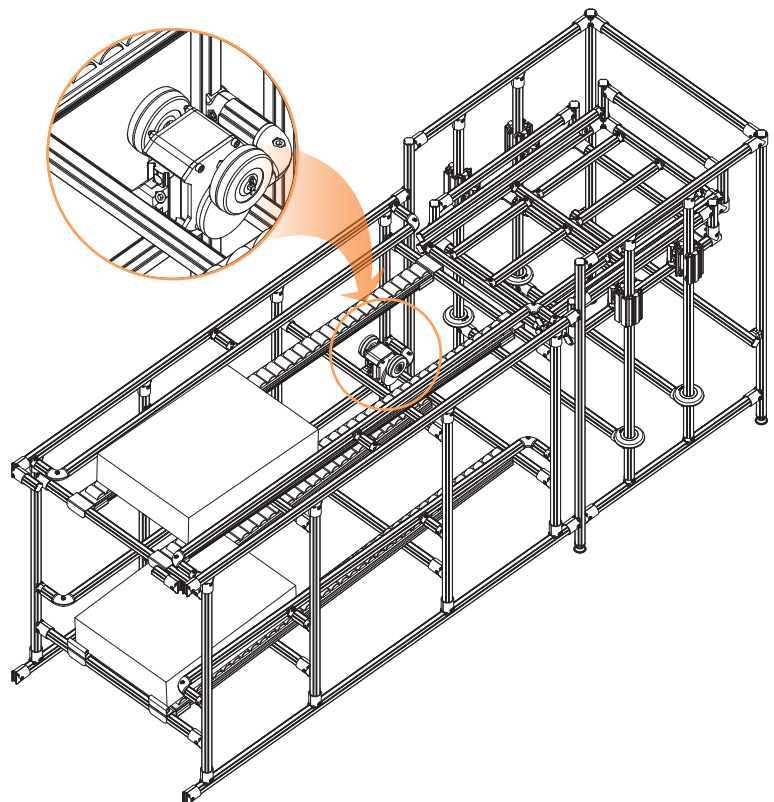

ROLLER TRACK CAP

Unit : mm

PRC-25A Roller Track Cap



Material	ABS
Weight	0.002kg
Qty/Box	1,500pcs

For AL Body 25 Series Silent Roller

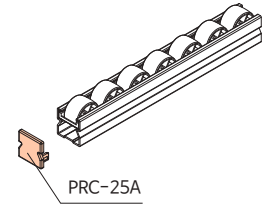
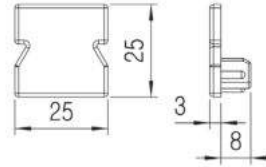

PRC-35 Roller Track Cap



Material	ABS
Weight	0.004kg
Qty/Box	1,000pcs

For 35 Series Standard Roller

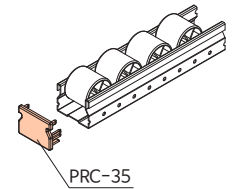
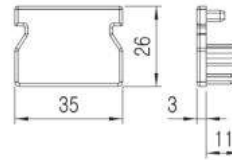

PRC-40 Roller Track Cap



Material	ABS
Weight	0.005kg
Qty/Box	1,000pcs

For 40 Series Standard Roller

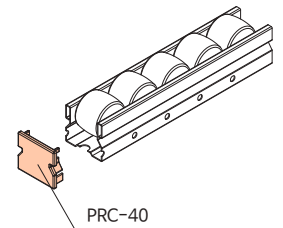
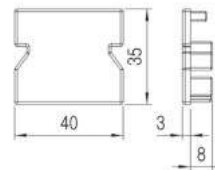

PRC-40A Roller Track Cap



Material	ABS
Weight	0.005kg
Qty/Box	1,000pcs

For AL Body 40 Series Silent Roller

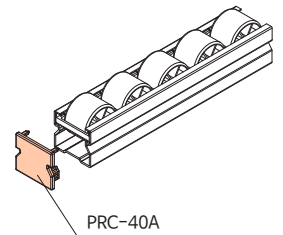
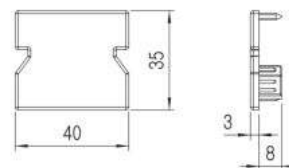

PRC-40G Roller Track Cap



Material	ABS
Weight	0.005kg
Qty/Box	1,000pcs

For GI Body 40 Series Silent Roller

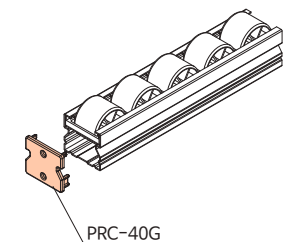
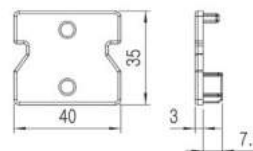

ROLLER TRACK CAP

Unit : mm

PRC-60 Roller Track Cap



Material	ABS
Weight	0.006kg
Qty/Box	600pcs

For GI Body 60 Series Standard Roller

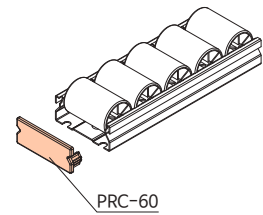
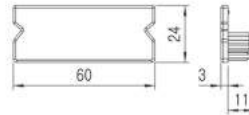

PRC-60

PRC-60A Roller Track Cap



Material	ABS
Weight	0.006kg
Qty/Box	600pcs

For Universal Roller UR-6067

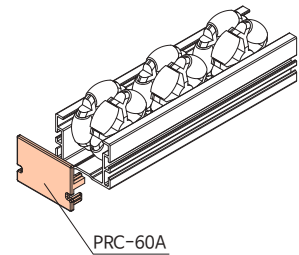
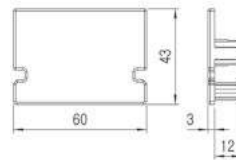

PRC-60A

PRC-60B Roller Track Cap



Material	ABS
Weight	0.006kg
Qty/Box	600pcs

For AL Body 60 Series Silent Roller

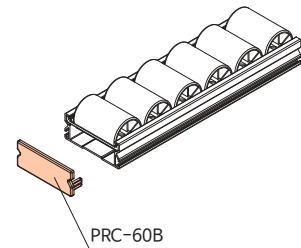
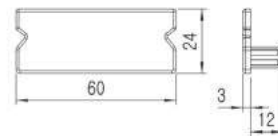

PRC-60B

PRC-60G Roller Track Cap



Material	ABS
Weight	0.006kg
Qty/Box	600pcs

For GI Body 60 Series Silent Roller

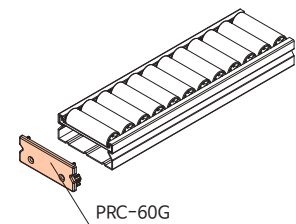
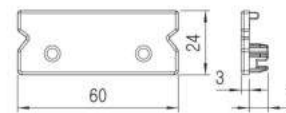

PRC-60G

PRC-85A Roller Track Cap



Material	ABS
Weight	0.010kg
Qty/Box	400pcs

For AL Body 85 Series Silent Roller

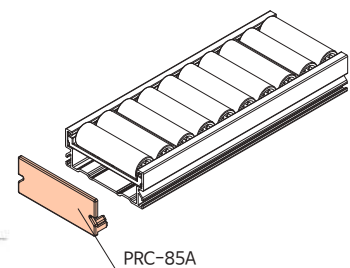
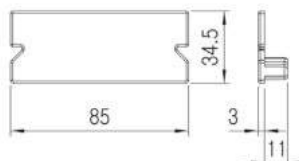

PRC-85A

ROLLER TRACK CAP

Unit : mm

PRC-85G Roller Track Cap



Material	ABS
Weight	0.010kg
Qty/Box	400pcs

Recycle Roller 85 Series
GI Body용

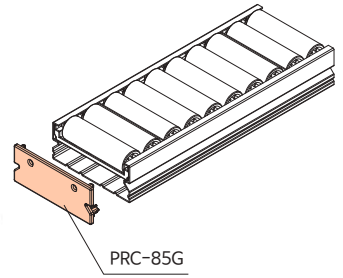
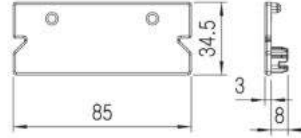

PRC-85G

PRC-100A Roller Track Cap



Material	ABS
Weight	0.011kg
Qty/Box	400pcs

Recycle Roller 100 Series
AL Body용

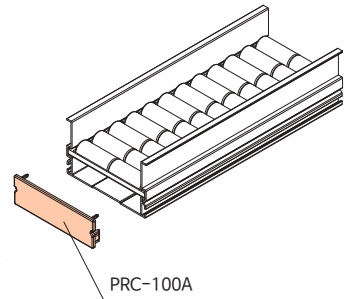
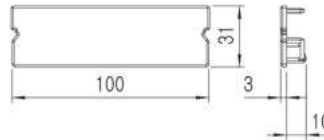

PRC-100A

ROLLER MOUNTING BRACKETS

ROLLER MOUNTING BRACKET (25 Series)

Surface Treatment-WZ
Unit : mm

GP-A25 Roller Mounting Bracket



Material	Steel
Weight	0.082kg
Qty/Box	90pcs

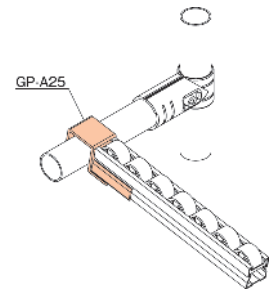
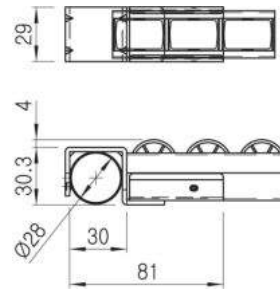

GP-B25 Roller Mounting Bracket / Tap Stop



Material	Steel
Weight	0.096kg
Qty/Box	60pcs

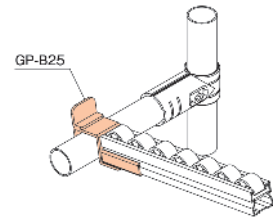
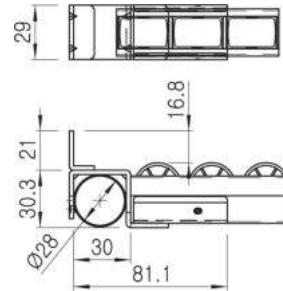

GP-E25 Roller Mounting Bracket / Center Support



Material	Steel
Weight	0.057kg
Qty/Box	120pcs

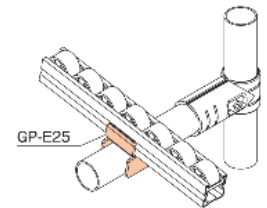
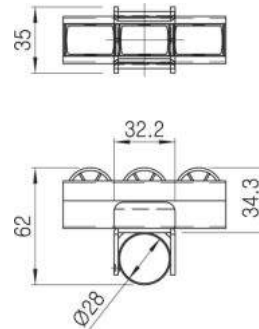

ROLLER MOUNTING BRACKETS

ROLLER TRACK MOUNTING BRKT (35 Series)

Unit : mm

GP-A35 Roller Mounting Bracket



Material	Steel
Weight	0.111kg
Qty/Box	80pcs

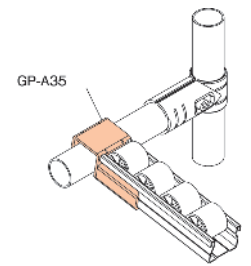
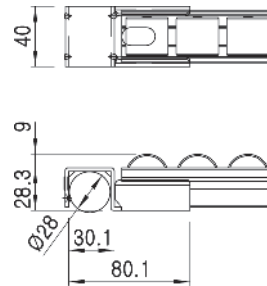

GP-B35 Roller Mounting Bracket / Tap Stop



Material	Steel
Weight	0.132kg
Qty/Box	60pcs

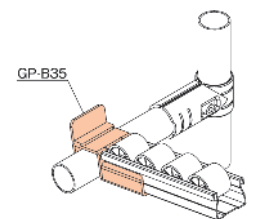
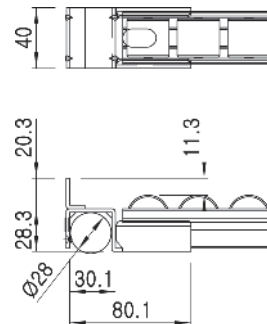

GP-B35-33 Roller Mounting Bracket / Tap Stop



Material	Steel
Weight	0.132kg
Qty/Box	60pcs

Bracket for assembling on the Joint

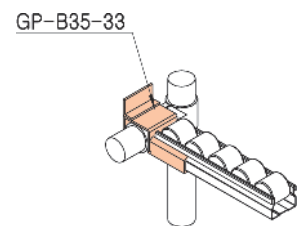
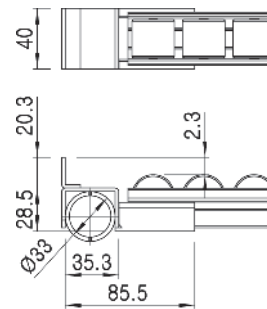

GP-B35-1 Roller Mounting Bracket / Tap Stop



Material	Steel
Weight	0.240kg
Qty/Box	70pcs

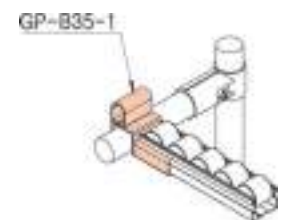
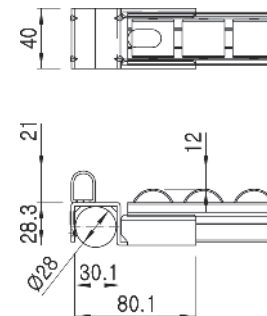

GP-B35-1-33 Roller Mounting Bracket / Tap Stop



Material	Steel
Weight	0.132kg
Qty/Box	60pcs

Bracket for assembling on the Joint

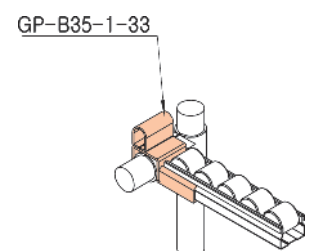
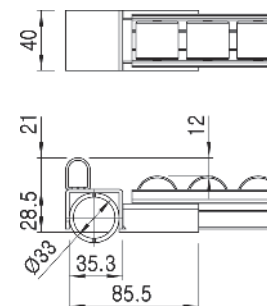

ROLLER MOUNTING BRACKETS

Unit : mm

GP-C35 Roller Track Union



Material	Steel
Weight	0.148kg
Qty/Box	60pcs

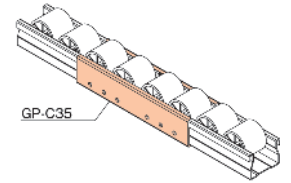
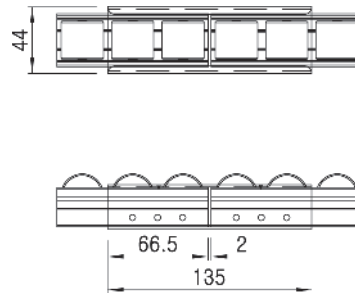

GP-D35 Roller Mounting Bracket / Drop Stop



Material	Steel
Weight	0.130kg
Qty/Box	70pcs

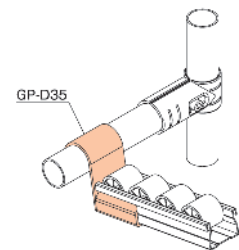
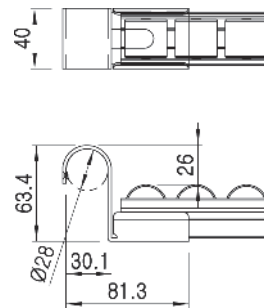

GP-E35 Roller Mounting Bracket / Center Support



Material	Steel
Weight	0.064kg
Qty/Box	120pcs

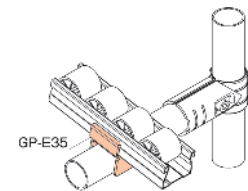
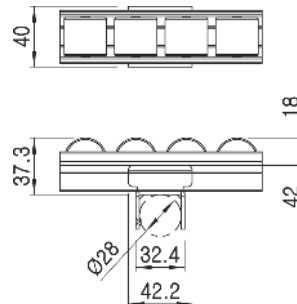

GP-E35-A12 Roller Mounting Bracket / Center Support



Material	Steel
Weight	0.117kg
Qty/Box	60pcs

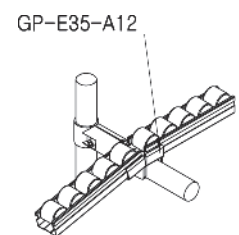
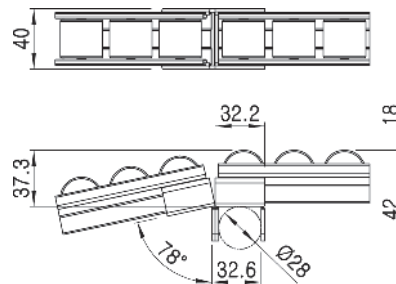

GP-HN35 Roller Track Union



Material	Steel
Weight	0.175kg
Qty/Box	36pcs

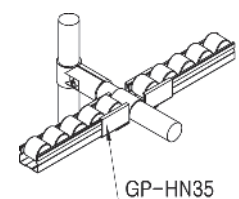
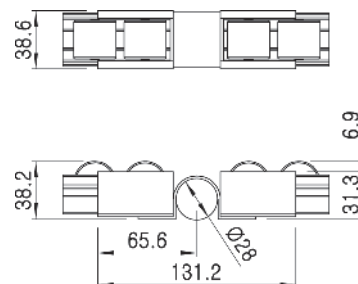

ROLLER MOUNTING BRACKETS

Unit : mm

GP-M35 Roller Mounting Bracket



Material	Steel
Weight	0.210kg
Qty/Box	30pcs

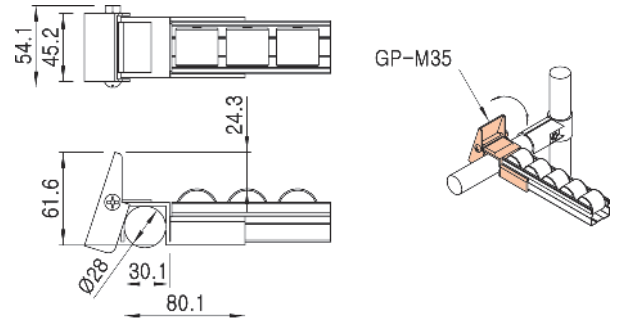

GP-VA35 Roller Mounting Bracket



Material	Steel
Weight	0.190kg
Qty/Box	45pcs

Roller Track angle can be changed

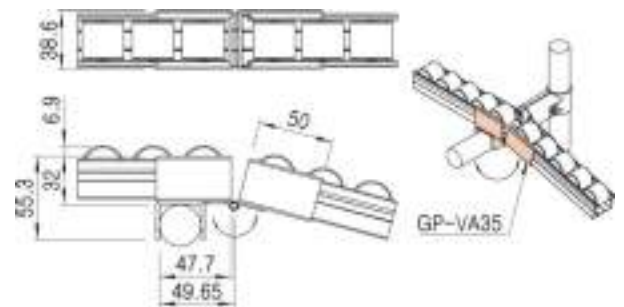

ROLLER MOUNTING BRACKETS

ROLLER MOUNTING BRACKET (40 Series)

Surface Treatment-WZ
Unit : mm

GP-A Roller Mounting Bracket



Material	Steel
Weight	0.141kg
Qty/Box	80pcs

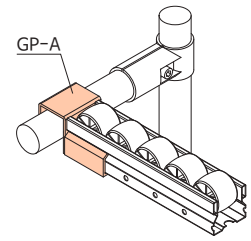
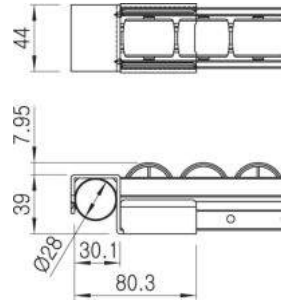

GP-A33 Roller Mounting Bracket



Material	Steel
Weight	0.142kg
Qty/Box	60pcs

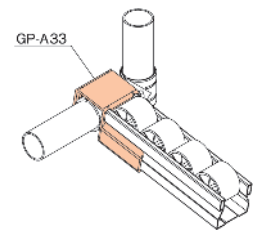
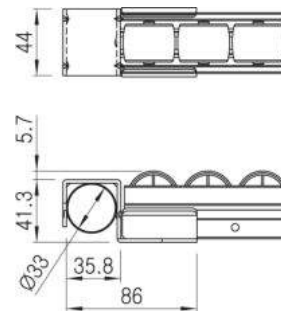

GP-APF Roller Mounting Bracket



Material	Steel
Weight	0.124kg
Qty/Box	80pcs

Bracket for 30x30 Profile

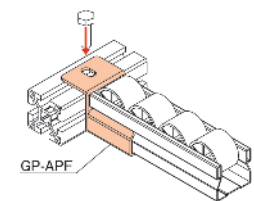
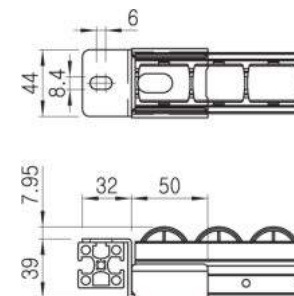

GP-B Roller Mounting Bracket / Tap Stop



Material	Steel
Weight	0.157kg
Qty/Box	60pcs

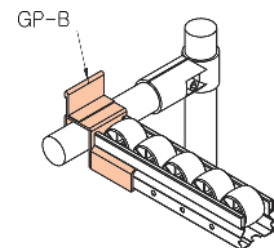
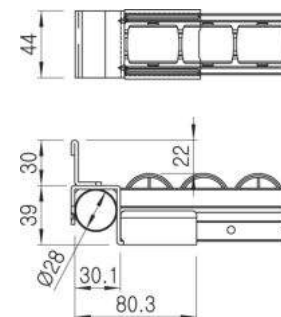

GP-B33 Roller Mounting Bracket / Tap Stop



Material	Steel
Weight	0.173kg
Qty/Box	50pcs

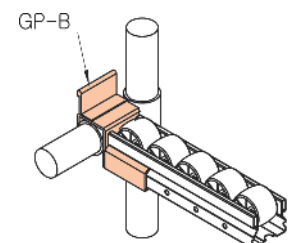
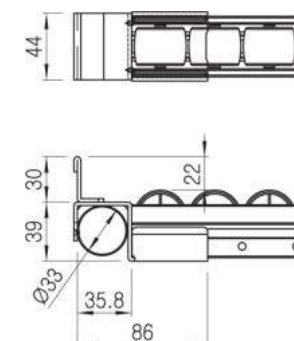

ROLLER MOUNTING BRACKETS

Surface Treatment-WZ
Unit : mm

GP-B-1 Roller Mounting Bracket / Tap Stop



Material	Steel
Weight	0.174kg
Qty/Box	50pcs

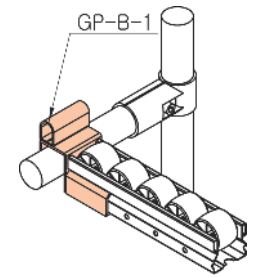
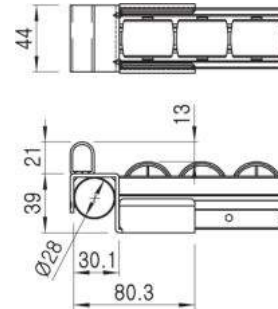

GP-B-1-33 Roller Mounting Bracket / Tap Stop



Material	Steel
Weight	0.174kg
Qty/Box	40pcs

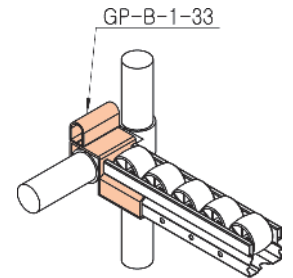
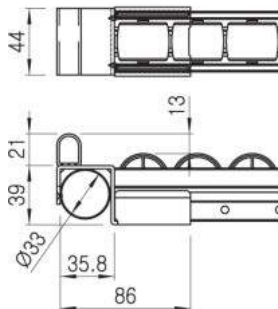

GP-C Roller Track Union



Material	Steel
Weight	0.121kg
Qty/Box	80pcs

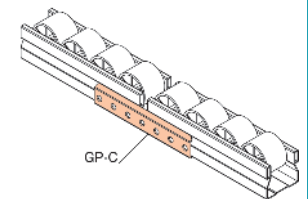
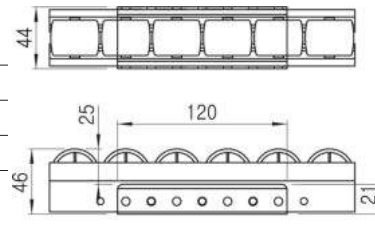

GP-C-1 Roller Track Union / Center Support



Material	Steel
Weight	0.170kg
Qty/Box	40pcs

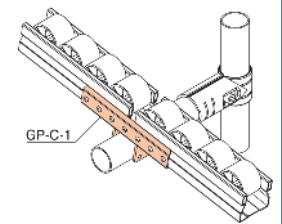
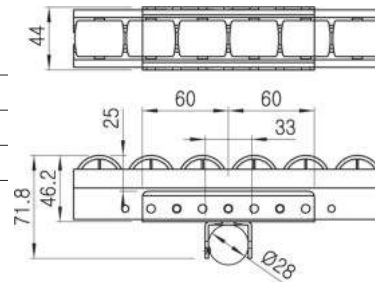

GP-C-1-33 Roller Track Union / Center Support



Material	Steel
Weight	0.170kg
Qty/Box	32pcs

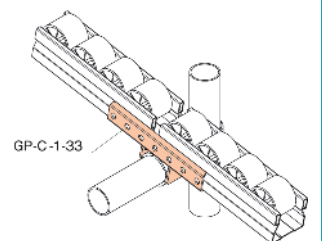
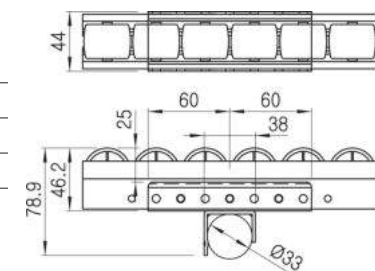

ROLLER MOUNTING BRACKETS

Surface Treatment-WZ
Unit : mm

GP-CN Roller Track Union



Material	Steel
Weight	0.232kg
Qty/Box	36pcs

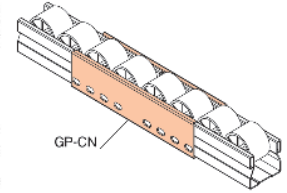
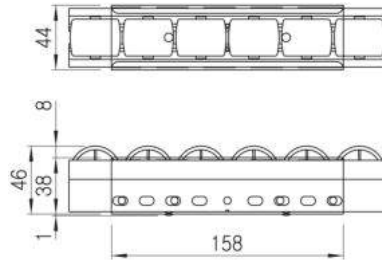

GP-DF Roller Mounting Bracket / Drop Stop



Material	Steel
Weight	0.194kg
Qty/Box	50pcs

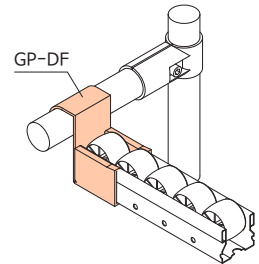
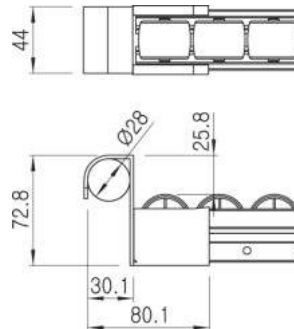

GP-DF-40 Roller Mounting Bracket / Drop Stop



Material	Steel
Weight	0.220kg
Qty/Box	30pcs

Bracket for 40x40 Profile

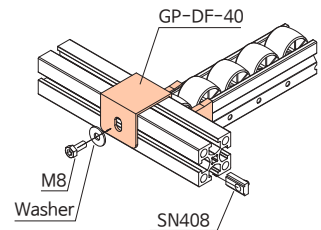
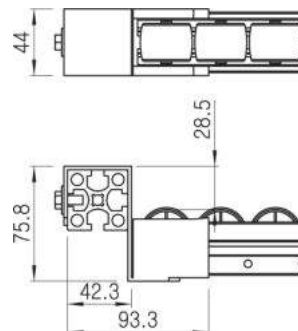

GP-DFJ Roller Mounting Bracket



Material	Steel
Weight	0.194kg
Qty/Box	50pcs

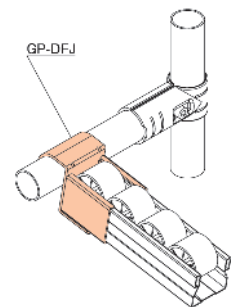
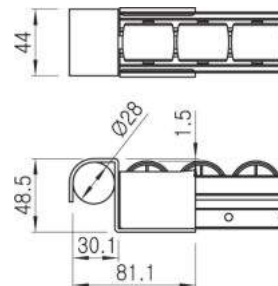

GP-DN Roller Mounting Bracket / Drop Stop



Material	Steel
Weight	0.160kg
Qty/Box	70pcs

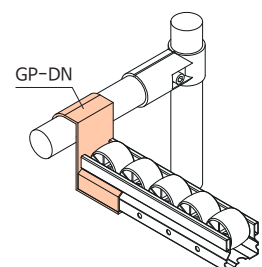
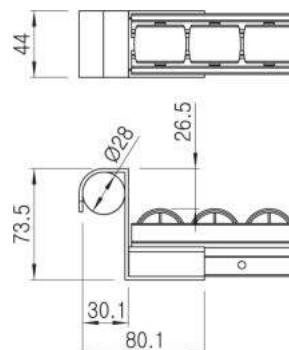

ROLLER MOUNTING BRACKETS

Surface Treatment-WZ
Unit : mm

GP-DN33 Roller Mounting Bracket / Drop Stop



Material	Steel
Weight	0.165kg
Qty/Box	70pcs

Bracket for assembling on the Joint

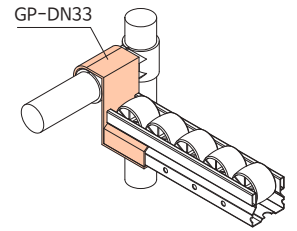
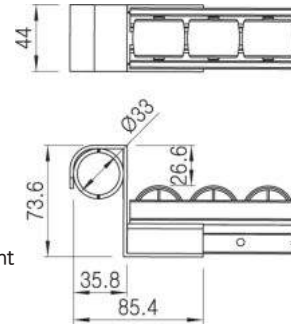

GP-E Roller Mounting Bracket / Center Support



Material	Steel
Weight	0.079kg
Qty/Box	100pcs

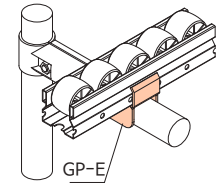
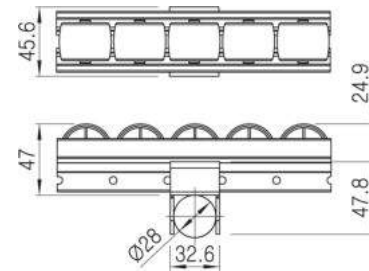

GP-E-33 Roller Mounting Bracket / Center Support



Material	Steel
Weight	0.085kg
Qty/Box	100pcs

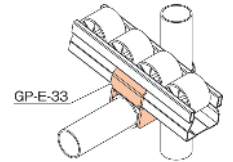
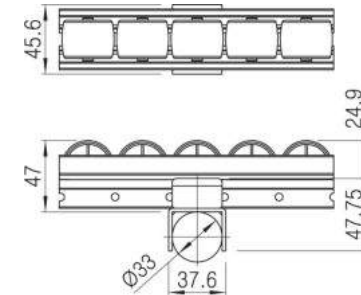

GP-EN Roller Mounting Bracket / Center Support



Material	Steel
Weight	0.217kg
Qty/Box	20pcs

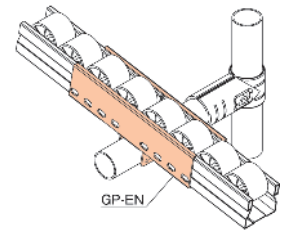
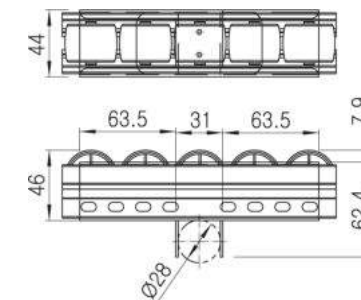

GP-EW Roller Mounting Bracket



Material	Steel
Weight	0.107kg
Qty/Box	70pcs

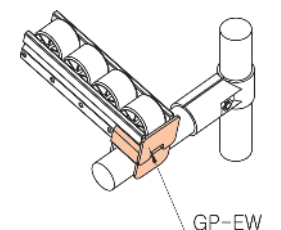
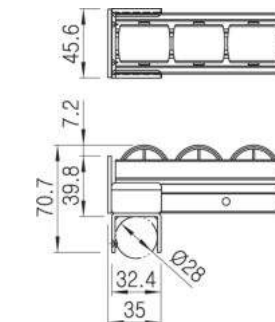

ROLLER MOUNTING BRACKETS

Surface Treatment-WZ
Unit : mm

GP-EW-33 Roller Mounting Bracket



Material	Steel
Weight	0.115kg
Qty/Box	70pcs

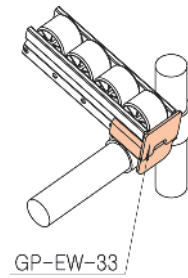
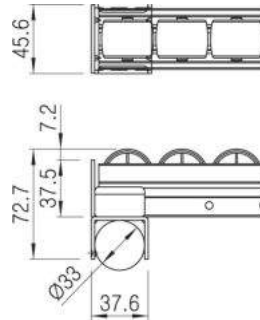

GP-F Roller Mounting Bracket



Material	Steel
Weight	0.175kg
Qty/Box	60pcs

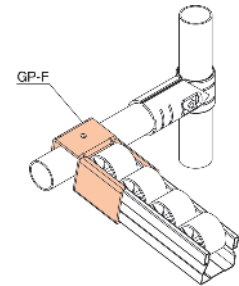
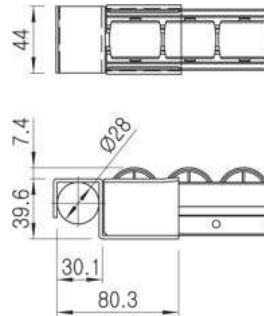

GP-F-33 Roller Mounting Bracket



Material	Steel
Weight	0.190kg
Qty/Box	36pcs

Bracket for assembling on the Joint

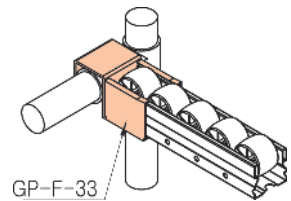
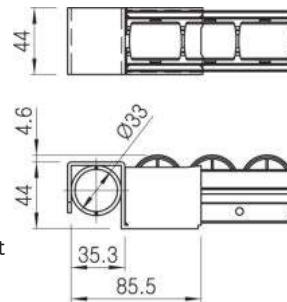

GP-F-40 Roller Mounting Bracket



Material	Steel
Weight	0.200kg
Qty/Box	50pcs

Bracket for 40x40 Profile

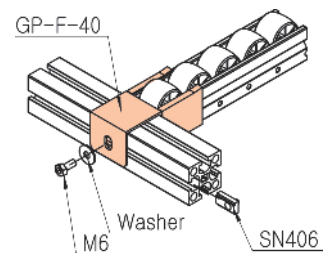
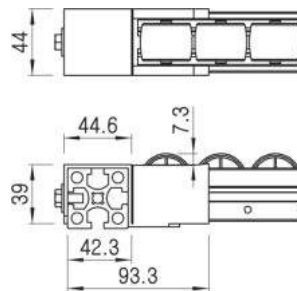

GP-FA Roller Mounting Bracket



Material	Steel
Weight	0.19kg
Qty/Box	50pcs

Installation Location can be changed easily by using Bolt

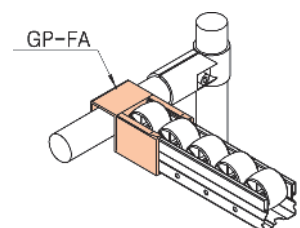
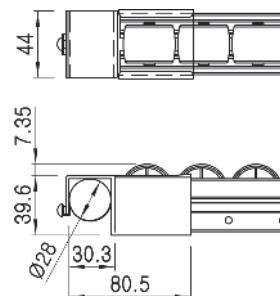

ROLLER MOUNTING BRACKETS

Surface Treatment-WZ
Unit : mm

GP-FC Roller Mounting Bracket / Tap Stop



Material	Steel
Weight	0.200kg
Qty/Box	42pcs

Installation Location can be changed easily by using Bolt

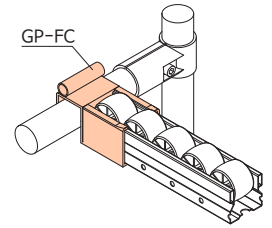
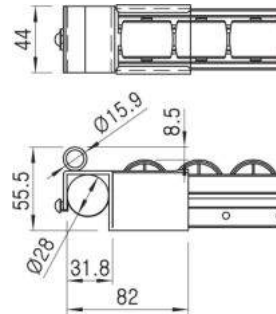

GP-G Roller Mounting Bracket / Tap Stop



Material	Steel
Weight	0.205kg
Qty/Box	40pcs

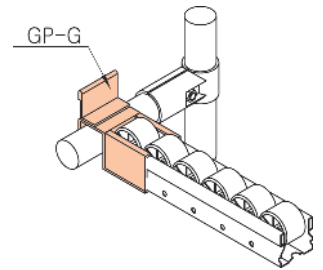
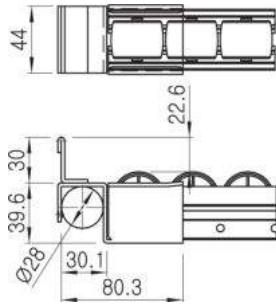

GP-G-33 Roller Mounting Bracket



Material	Steel
Weight	0.220kg
Qty/Box	30pcs

Bracket for assembling on the Joint

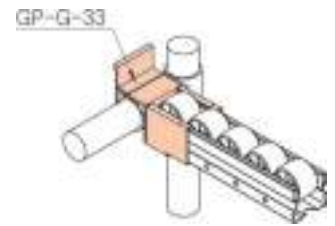
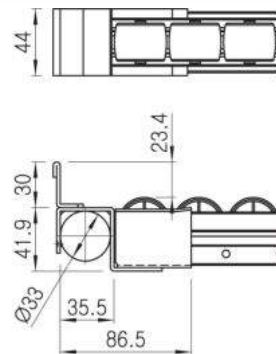

GP-HF Roller Track Union



Material	Steel
Weight	0.230kg
Qty/Box	24pcs

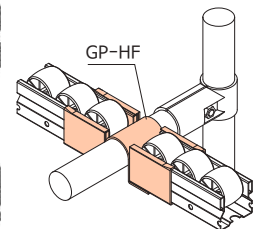
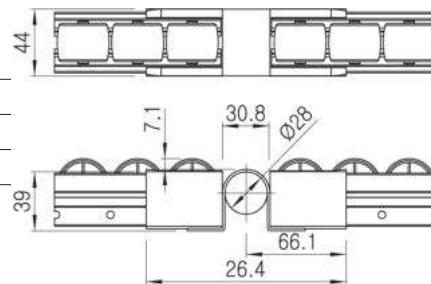

GP-HN Roller Track Union



Material	Steel
Weight	0.279kg
Qty/Box	30pcs

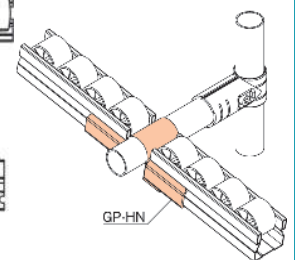
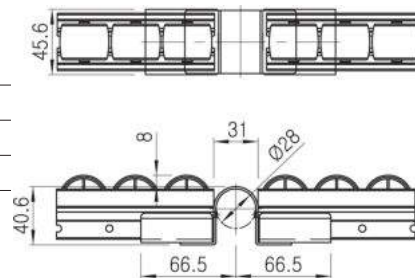

ROLLER MOUNTING BRACKETS

Surface Treatment-WZ
Unit : mm

GP-HN-33 Roller Track Mounting Bracket



Material	Steel
Weight	0.323kg
Qty/Box	30pcs

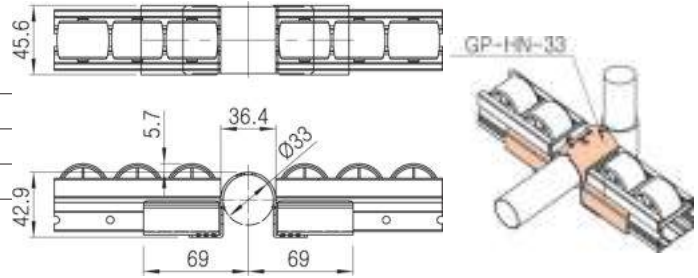

GP-HU Roller Mounting Bracket



Material	Steel
Weight	0.230kg
Qty/Box	30pcs

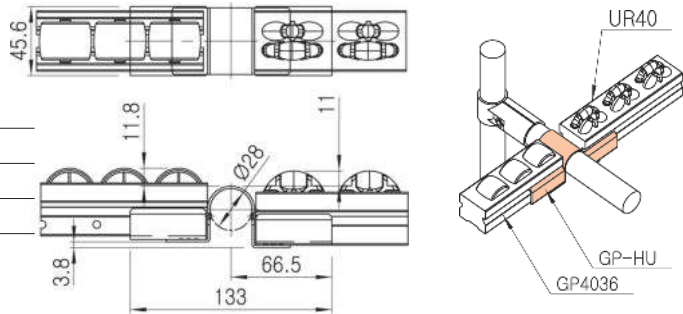

GP-HP Roller Mounting Bracket



Material	Steel
Weight	0.215kg
Qty/Box	24pcs

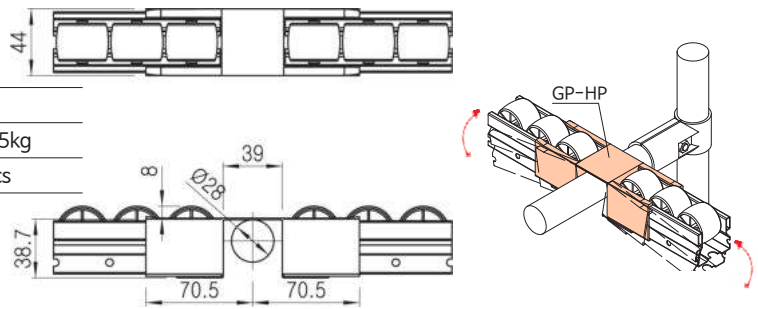

GP-HS Adjustable Roller to Slide Pipe Union



Material	Steel
Weight	0.200kg
Qty/Box	40pcs

Height of 40 Series Roller and Slide Pipe is same

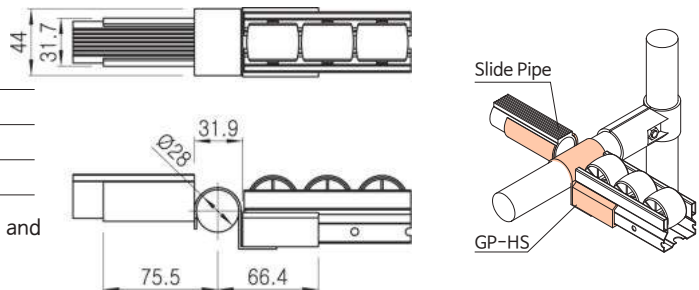

GP-K Roller Mounting Bracket



Material	Steel
Weight	-
Qty/Box	-

Bracket installs Slide Pipe at an angle to the Roller

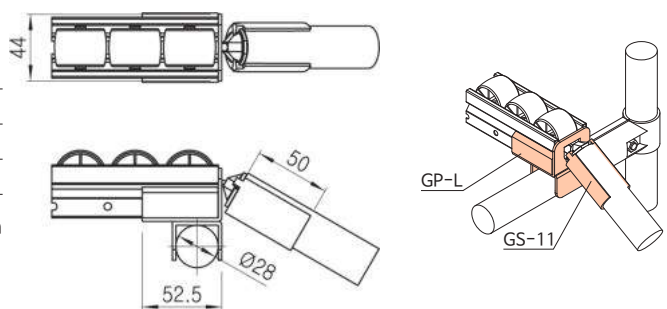

ROLLER MOUNTING BRACKETS

Surface Treatment-WZ
Unit : mm

GP-L Roller Mounting Bracket



Material	Steel
Weight	0.144kg
Qty/Box	60pcs

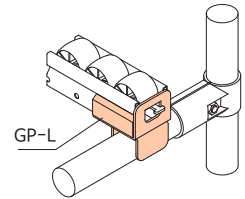
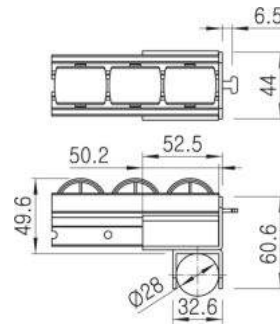

GP-L-33 Roller Mounting Bracket



Material	Steel
Weight	0.150kg
Qty/Box	60 pcs

Bracket for assembling on the Joint

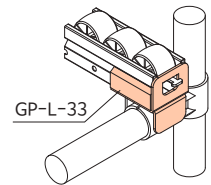
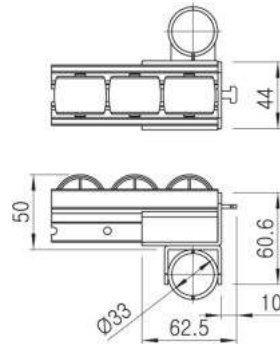

GP-LW Roller Mounting Bracket



Material	Steel
Weight	0.144kg
Qty/Box	70 pcs

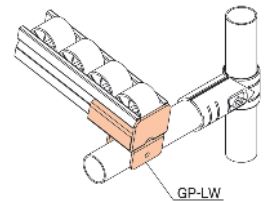
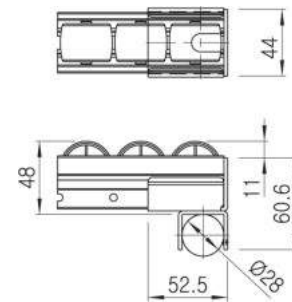

GP-LW-33 Roller Mounting Bracket



Material	Steel
Weight	0.150kg
Qty/Box	70pcs

Bracket for assembling on the Joint

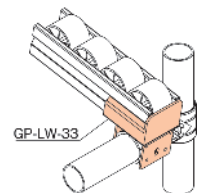
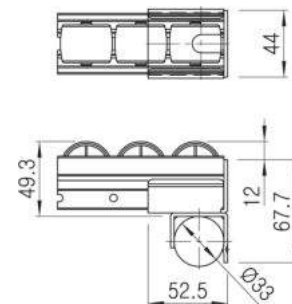

GP-LWB Roller Mounting Bracket / Tap Stop



Material	Steel
Weight	0.180kg
Qty/Box	50pcs

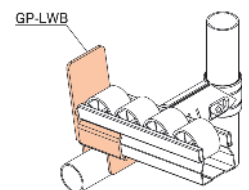
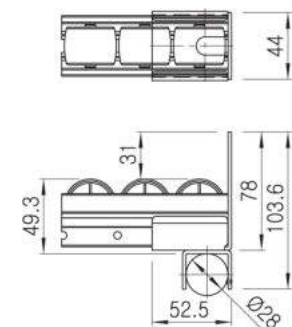

ROLLER MOUNTING BRACKETS

Surface Treatment-WZ
Unit : mm

GP-M Roller Mounting Bracket



Material	Steel
Weight	0.239kg
Qty/Box	30 pcs

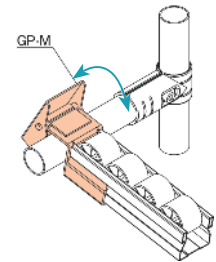
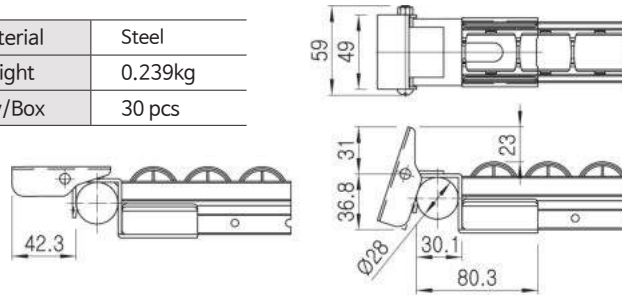

GP-NA Roller Mounting Bracket



Material	Steel
Weight	0.100kg
Qty/Box	80 pcs

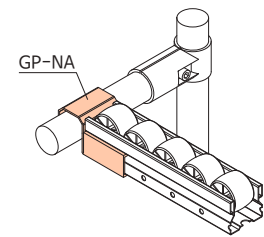
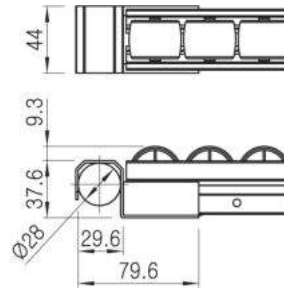

GP-NB Roller Mounting Bracket / Tap Stop



Material	Steel
Weight	0.129kg
Qty/Box	60 pcs

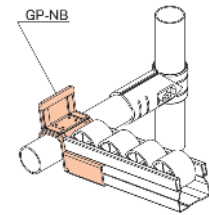
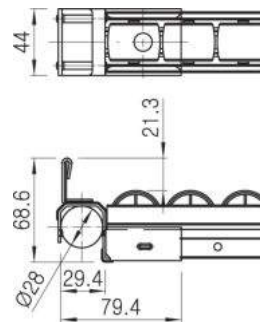

GP-SB Absorber Mounting Bracket



Material	Steel
Weight	0.107kg
Qty/Box	70pcs

Bracket for Gas Spring

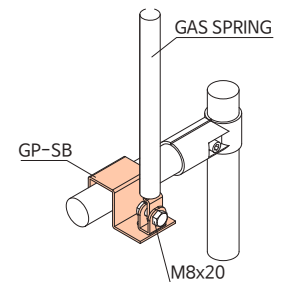
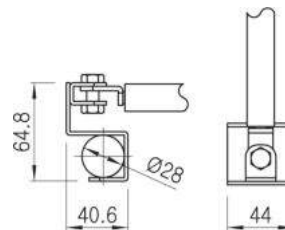

GP-VA40 Roller Mounting Bracket



Material	Steel
Weight	0.220kg
Qty/Box	35pcs

Roller Track angle can be changed

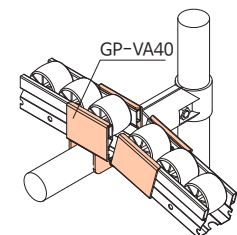
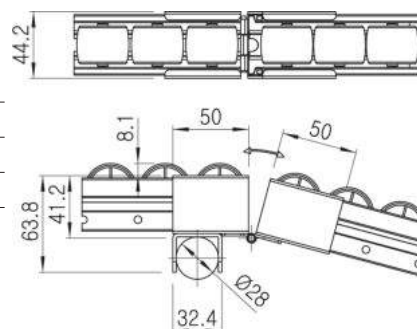

ROLLER MOUNTING BRACKETS

Surface Treatment-WZ
Unit : mm

GP-11 Adjustable Roller Union



Material	Steel
Weight	0.131kg
Qty/Box	60 pcs

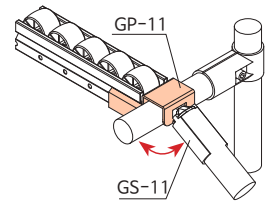
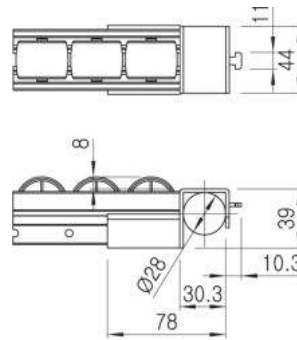

GP-12 Adjustable Roller Union



Material	Steel
Weight	0.096kg
Qty/Box	180pcs

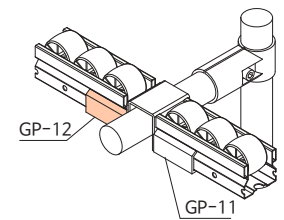
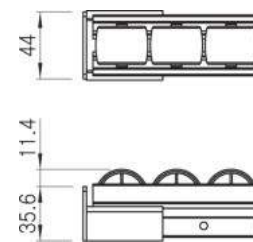

GP-13 Adjustable Roller Union



Material	Steel
Weight	0.173kg
Qty/Box	40pcs

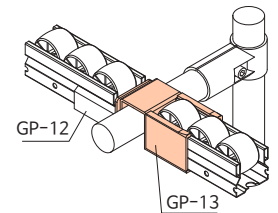
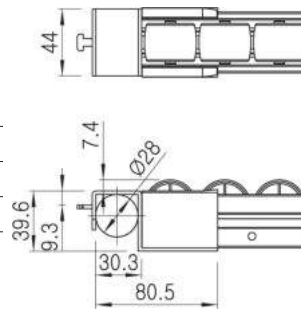

GP-14 Adjustable Roller Union



Material	Steel
Weight	0.096kg
Qty/Box	140pcs

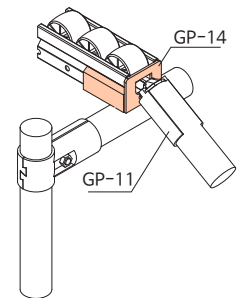
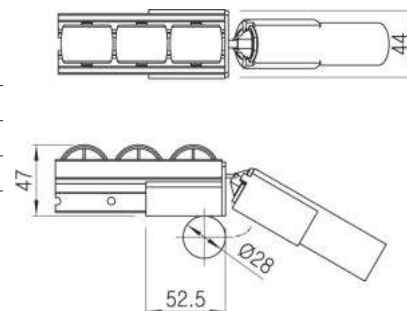

ROLLER MOUNTING BRACKETS

ROLLER MOUNTING BRACKET (60 Series)

Surface Treatment-WZ
Unit : mm

GP-A60 Roller Mounting Bracket



Material	Steel
Weight	0.164kg
Qty/Box	60pcs

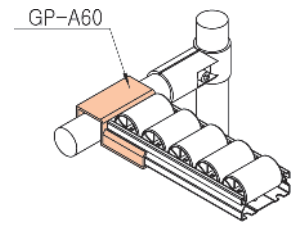
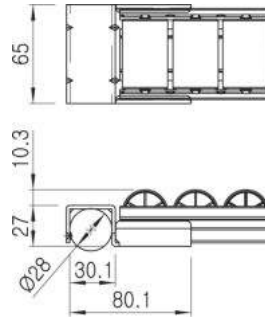

GP-A60-33 Roller Mounting Bracket



Material	Steel
Weight	0.164kg
Qty/Box	50pcs

Insert GAP-08 to bridge a gap

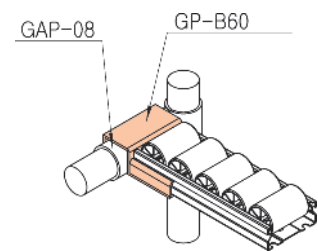
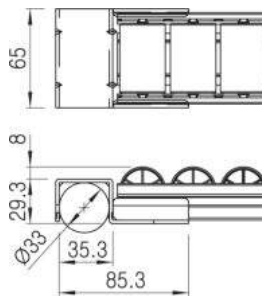

GP-APF60 Roller Mounting Bracket



Material	Steel
Weight	0.140kg
Qty/Box	50pcs

Bracket for 40x40 Profile

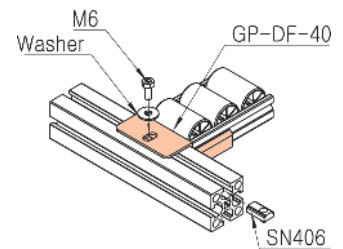
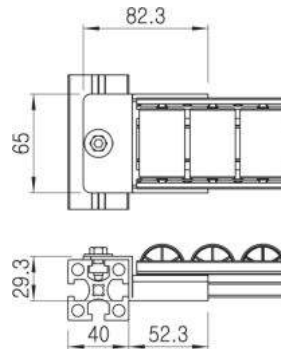

GP-B60 Roller Mounting Bracket / Tap Stop



Material	Steel
Weight	0.250kg
Qty/Box	30pcs

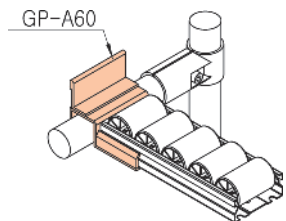
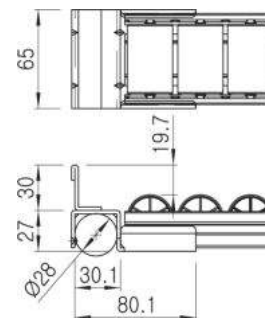

GP-B60-33 Roller Mounting Bracket / Tap Stop



Material	Steel
Weight	0.250kg
Qty/Box	20pcs

Insert GAP-08 to bridge a gap

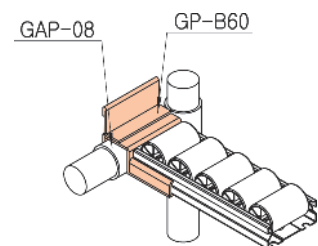
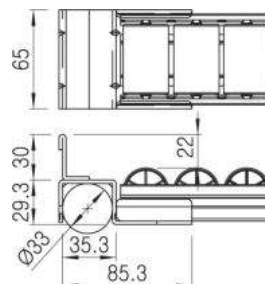

ROLLER MOUNTING BRACKETS

Surface Treatment-WZ
Unit : mm

GP-B60-1 Roller Mounting Bracket / Tap Stop



Material	Steel
Weight	0.220kg
Qty/Box	30pcs

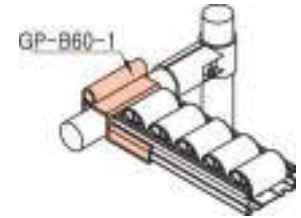
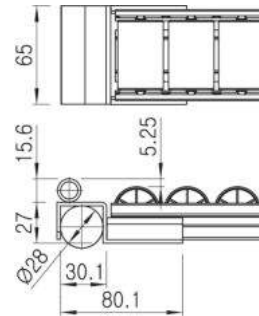

GP-CN60 Roller Track Union



Material	Steel
Weight	0.168kg
Qty/Box	68pcs

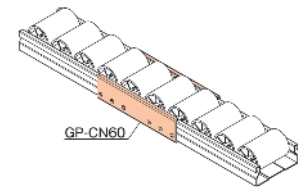
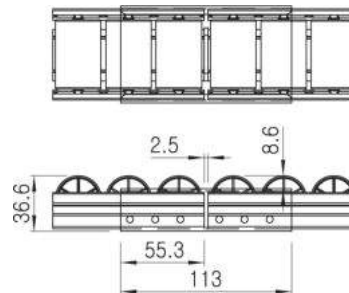

GP-D60 Roller Mounting Bracket / Drop Stop



Material	Steel
Weight	0.205kg
Qty/Box	40pcs

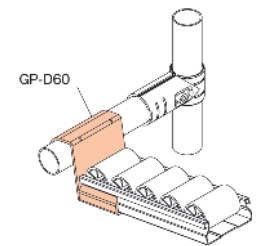
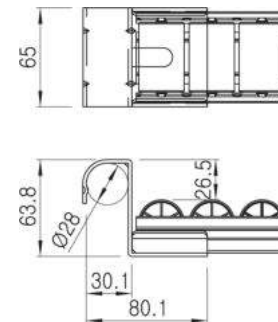

GP-D60-33 Roller Mounting Bracket / Drop Stop



Material	Steel
Weight	0.205kg
Qty/Box	40pcs

Insert GAP-08 to bridge a gap

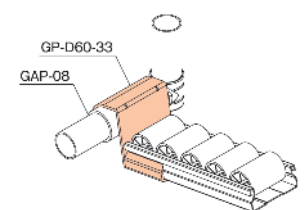
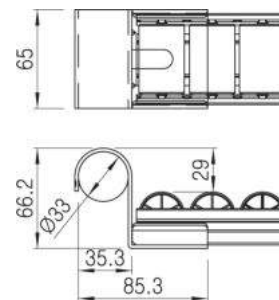

GP-DF60J Roller Mounting Bracket



Material	Steel
Weight	0.174kg
Qty/Box	40pcs

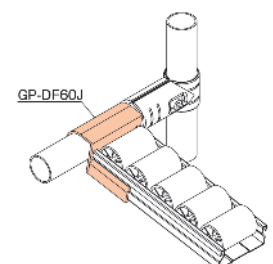
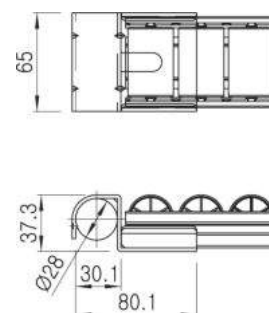

ROLLER MOUNTING BRACKETS

Surface Treatment-WZ
Unit : mm

GP-E60 Roller Mounting Bracket / Center Support



Material	Steel
Weight	0.095kg
Qty/Box	100pcs

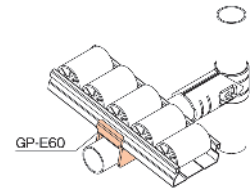
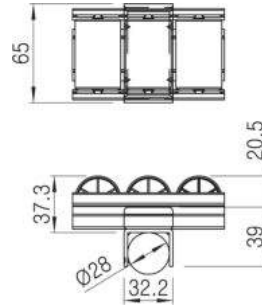

GP-E60-33 Roller Mounting Bracket / Center Support



Material	Steel
Weight	0.095kg
Qty/Box	80pcs

Insert GAP-08 to bridge a gap

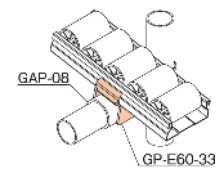
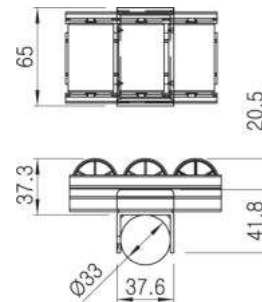

GP-EN60 Roller Track Union / Center Support



Material	Steel
Weight	0.158kg
Qty/Box	20pcs

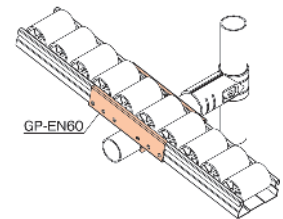
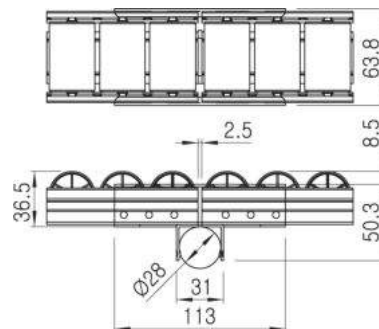

GP-EH60 Roller Mounting Bracket / Center Support



Material	Steel
Weight	0.175kg
Qty/Box	50pcs

Bracket for adjusting Roller height of 60 Series same with 40 Series

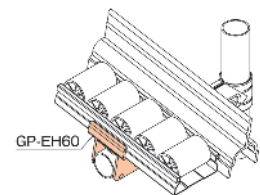
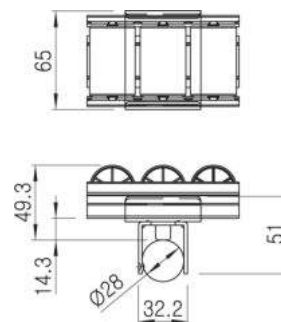

GP-FC60 Roller Mounting Bracket



Material	Steel
Weight	0.168kg
Qty/Box	50pcs

Installation Location can be changed easily by using Bolt

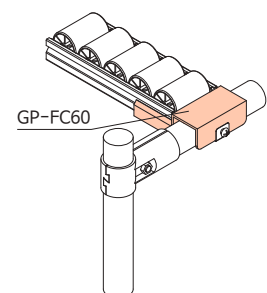
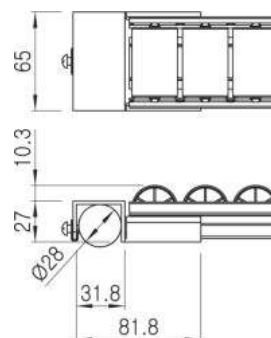

ROLLER MOUNTING BRACKETS

Surface Treatment-WZ
Unit : mm

GP-HN60 Roller Mounting Unoin



Material	Steel
Weight	0.254kg
Qty/Box	35pcs

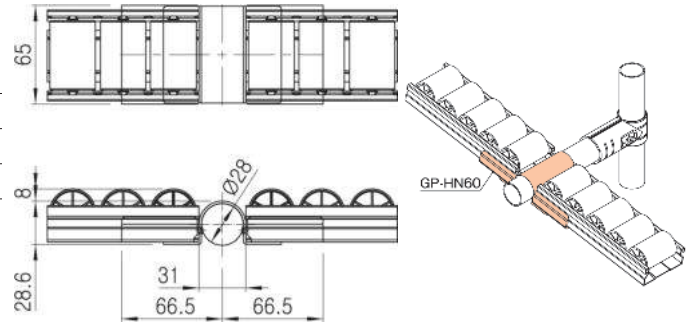

GP-L60 Roller Mounting Bracket



Material	Steel
Weight	0.187kg
Qty/Box	30pcs

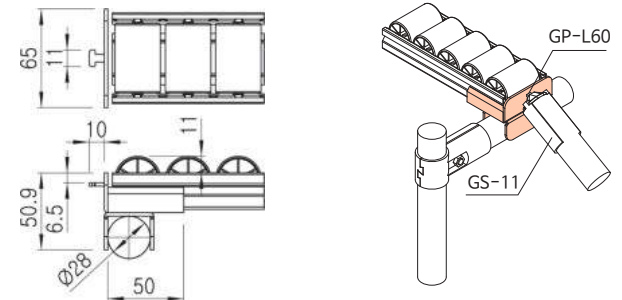

GP-L60W Roller Mounting Bracket



Material	Steel
Weight	0.187kg
Qty/Box	30pcs

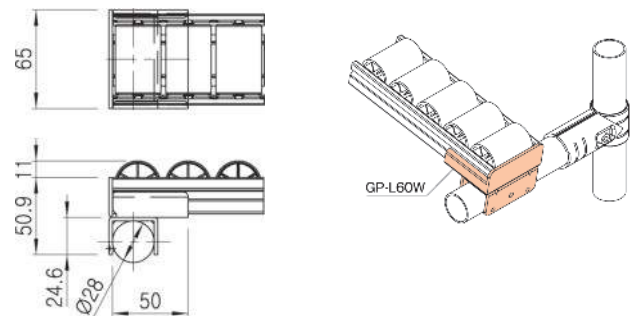

GP-L60W-33 Roller Mounting Bracket



Material	Steel
Weight	0.187kg
Qty/Box	30pcs

Insert GAP-08 to bridge a gap

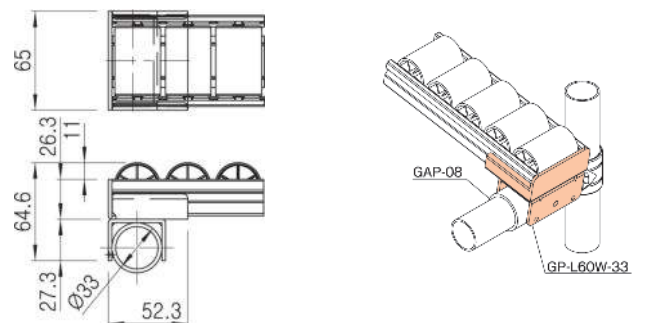

GP-L60WB Roller Mounting Bracket / Tap Stop



Material	Steel
Weight	0.220kg
Qty/Box	40pcs

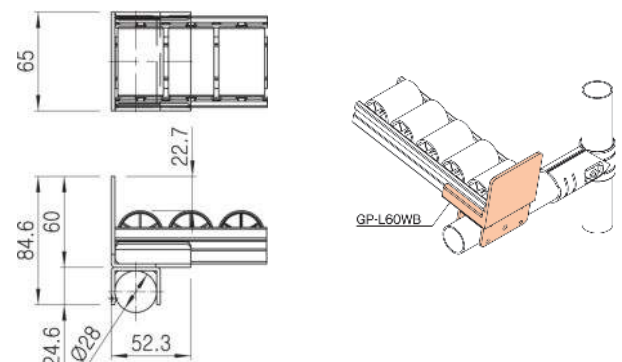

ROLLER MOUNTING BRACKETS

Surface Treatment-WZ
Unit : mm

GP-M60 Roller Mounting Bracket



Material	Steel
Weight	0.280kg
Qty/Box	30pcs

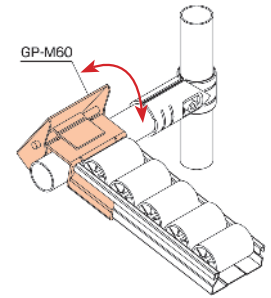
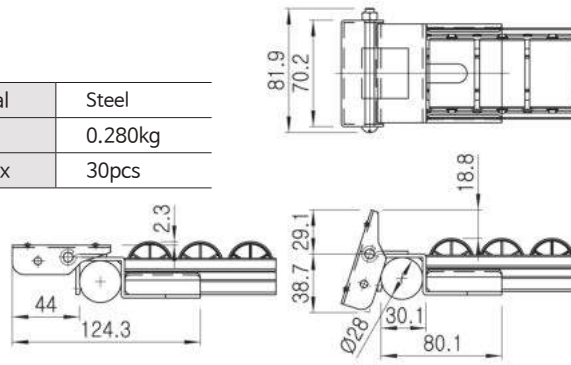

ROLLER MOUNTING BRACKETS

ROLLER MOUNTING BRACKET (85 Series)

Surface Treatment-WZ
Unit : mm

GP-A85 Roller Mounting Bracket



Material	Steel
Weight	0.205kg
Qty/Box	40pcs

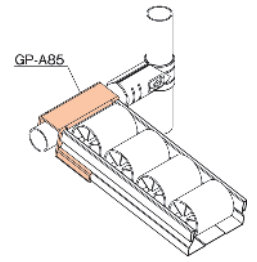
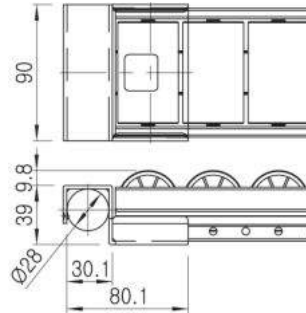

GP-A85-33 Roller Mounting Bracket



Material	Steel
Weight	0.205kg
Qty/Box	40pcs

Insert GAP-08 to bridge a gap

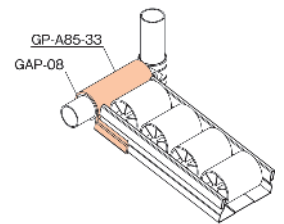
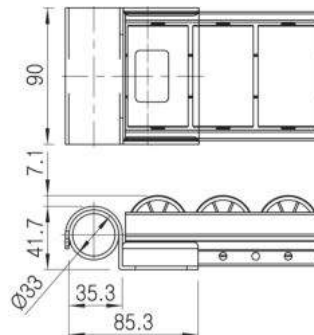

GP-AN85 Roller Mounting Bracket / Drop Stop



Material	Steel
Weight	0.253kg
Qty/Box	40pcs

Height of Bracket is same with Roller

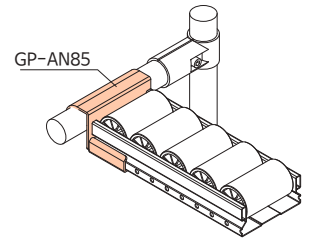
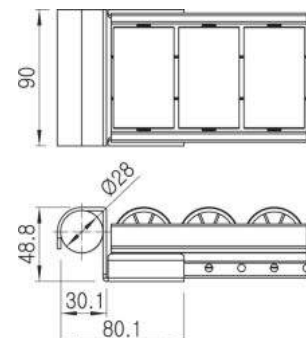

GP-B85 Roller Mounting Bracket / Tap Stop



Material	Steel
Weight	0.300kg
Qty/Box	30pcs

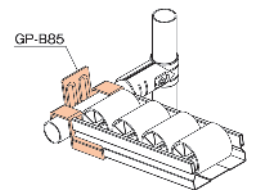
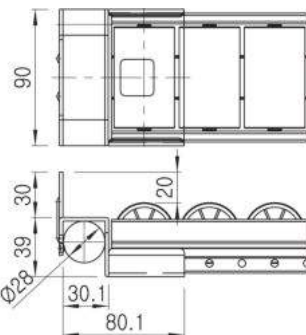

GP-B85-N Roller Mounting Bracket



Material	Steel
Weight	0.170kg
Qty/Box	40pcs

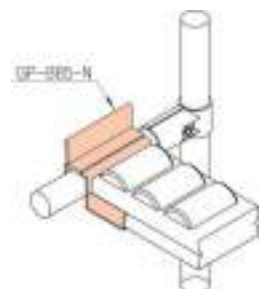
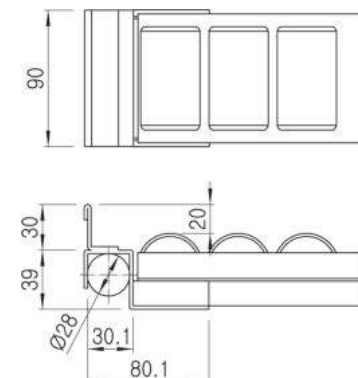

ROLLER MOUNTING BRACKETS

Surface Treatment-WZ
Unit : mm

GP-B85-33 Roller Mounting Bracket / Tap Stop



Material	Steel
Weight	0.300kg
Qty/Box	20pcs

Insert GAP-08 to bridge a gap

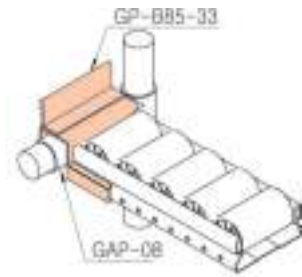
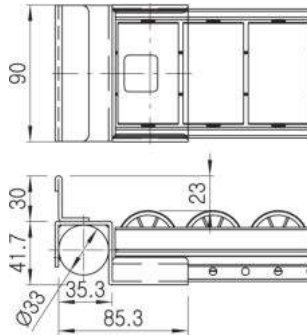

GP-B85-1 Roller Mounting Bracket / Tap Stop



Material	Steel
Weight	0.318kg
Qty/Box	20pcs

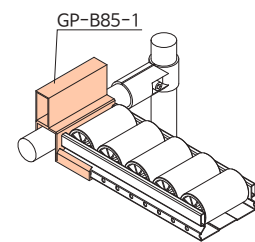
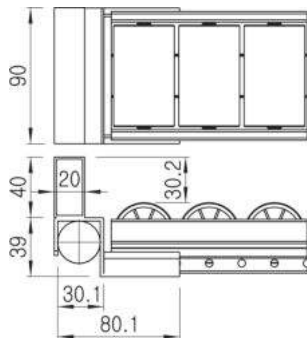

GP-B85-1-33 Roller Mounting Bracket / Tap Stop



Material	Steel
Weight	0.318kg
Qty/Box	15pcs

Insert GAP-08 to bridge a gap

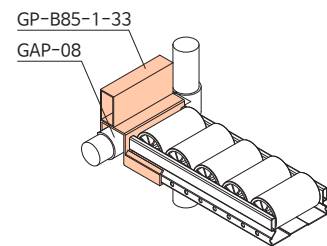
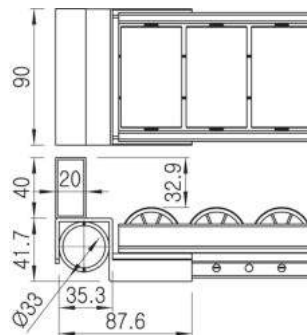

GP-B85-2 Roller Mounting Bracket / Tap Stop



Material	Steel
Weight	0.300kg
Qty/Box	20pcs

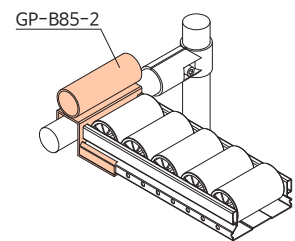
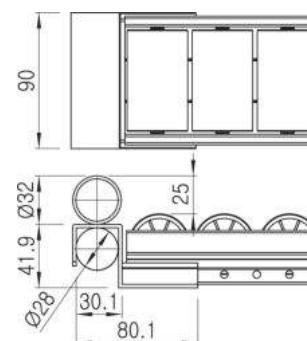

GP-C85 Roller Track Union



Material	Steel
Weight	0.140kg
Qty/Box	70pcs

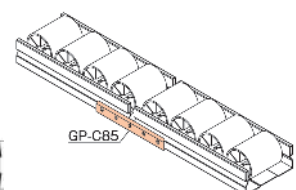
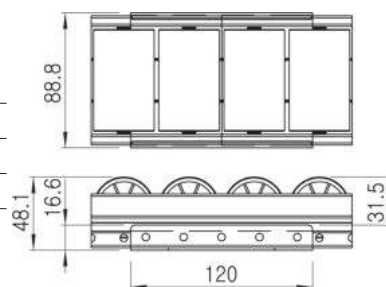

ROLLER MOUNTING BRACKETS

Surface Treatment-WZ
Unit : mm

GP-C85-1 Roller Track Union / Center Support



Material	Steel
Weight	0.243kg
Qty/Box	20pcs

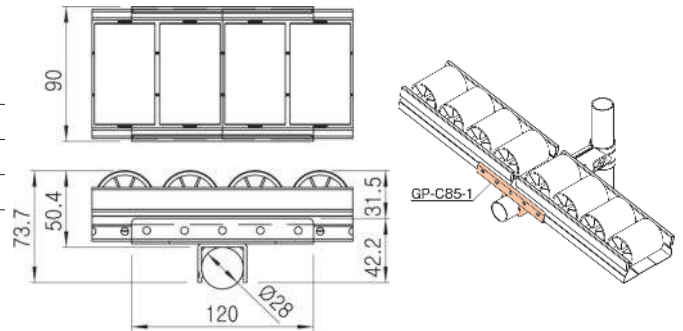

GP-D85 Roller Mounting Bracket / Drop Stop



Material	Steel
Weight	0.235kg
Qty/Box	30pcs

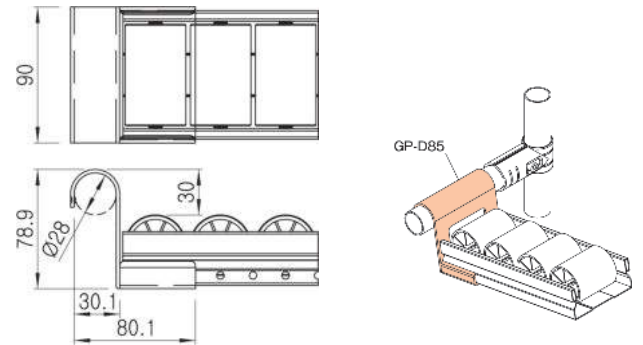

GP-E85 Roller Mounting Bracket / Center Support



Material	Steel
Weight	0.124kg
Qty/Box	80pcs

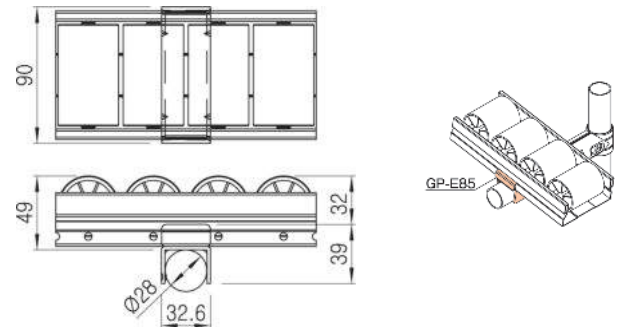

GP-E85-33 Roller Mounting Bracket / Center Support



Material	Steel
Weight	0.124kg
Qty/Box	60pcs

Insert GAP-08 to bridge a gap

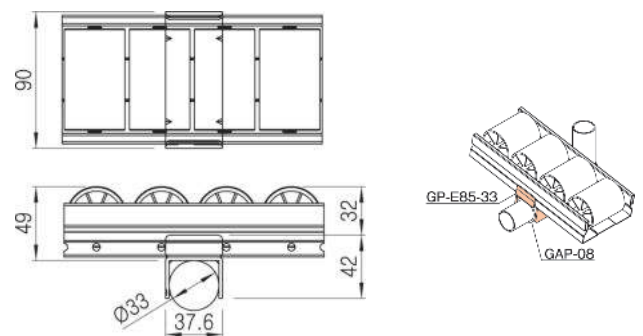

GP-EN85 Roller Track Union / Center Support



Material	Steel
Weight	0.414kg
Qty/Box	12pcs

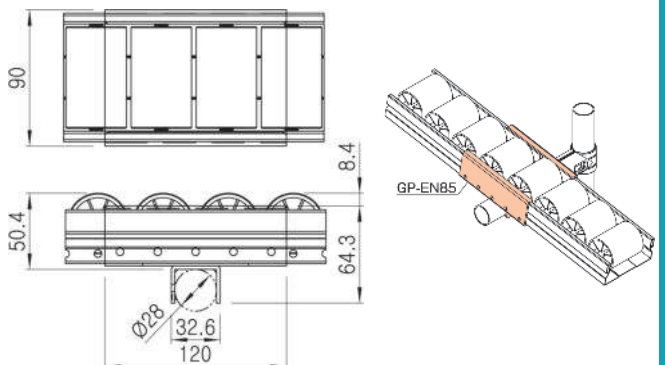

ROLLER MOUNTING BRACKETS

Surface Treatment-WZ
Unit : mm

GP-L85W Roller Mounting Bracket



Material	Steel
Weight	0.264kg
Qty/Box	24pcs

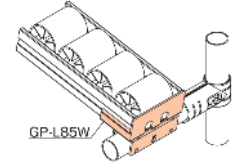
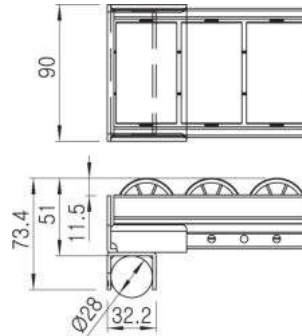

GP-L85W-33 Roller Mounting Bracket



Material	Steel
Weight	0.265kg
Qty/Box	24pcs

Insert GAP-08 to bridge a gap

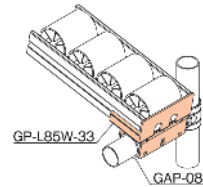
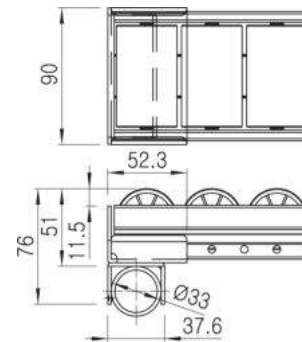

GP-M85 Roller Mounting Bracket



Material	Steel
Weight	0.410kg
Qty/Box	20pcs

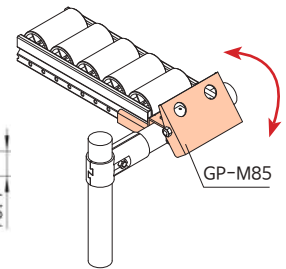
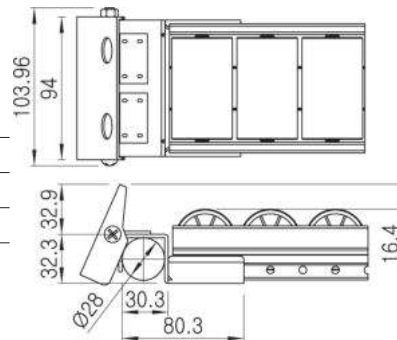

GP-M85-33 Roller Mounting Bracket



Material	Steel
Weight	0.442kg
Qty/Box	20pcs

Insert GAP-08 to bridge a gap

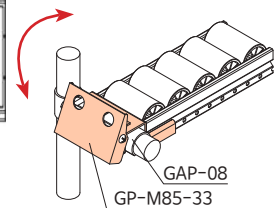
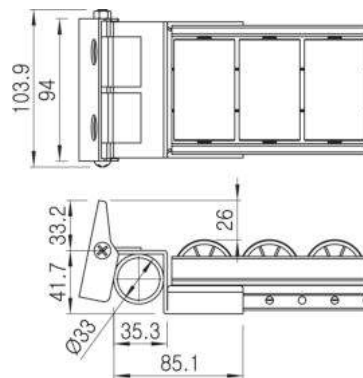

SLIDE PIPE MOUNTING BRACKETS

Unit : mm

* Surface Treatment - WZ

GS-AN Slide Pipe Mount



Material	Steel
Weight	0.106kg
Q'ty/Box	100pcs

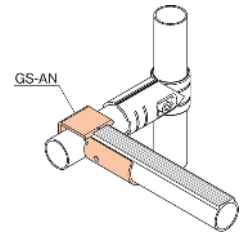
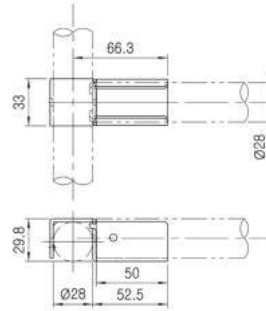

GS-A-33 Slide Pipe Mount



Material	Steel
Weight	0.106kg
Q'ty/Box	80pcs

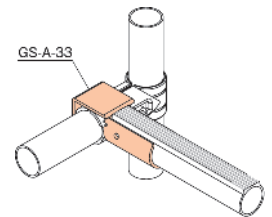
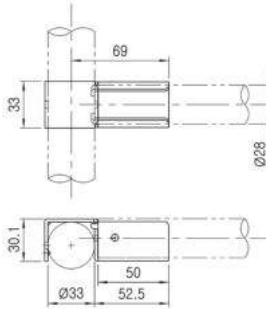

GS-BN Slide Pipe Mount / Tap Stop



Material	Steel
Weight	0.130kg
Q'ty/Box	70pcs

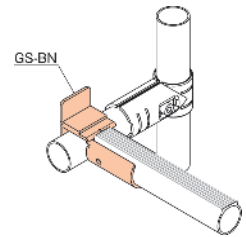
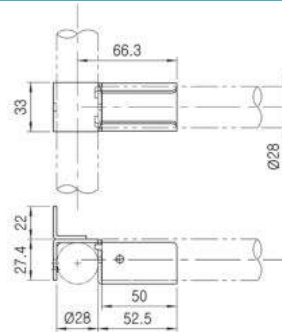

GS-B-33 Slide Pipe Mount / Tap Stop



Material	Steel
Weight	0.130kg
Q'ty/Box	70pcs

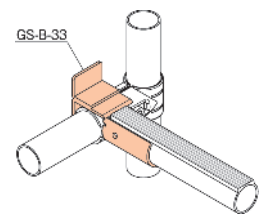
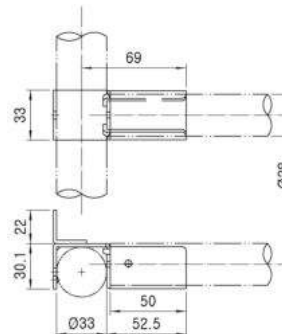

GS-B-1 Slide Pipe Mount / Tap Stop



Material	Steel
Weight	0.116kg
Q'ty/Box	70pcs

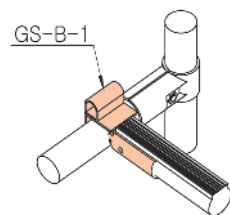
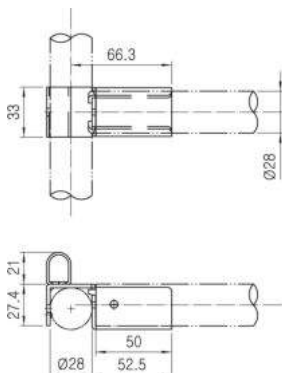

SLIDE PIPE MOUNTING BRACKETS

* Surface Treatment - WZ

Unit : mm

GS-B33-1 Slide Pipe Mount / Tap Stop



Material	Steel
Weight	0.116kg
Q'ty/Box	50pcs

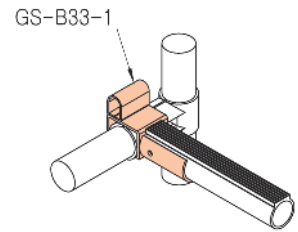
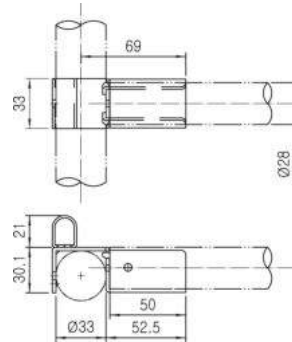

GS-C Slide Pipe Mount Guide Bracket



Material	Steel
Weight	0.085kg
Q'ty/Box	80pcs

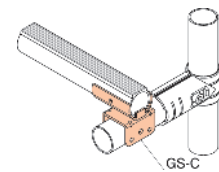
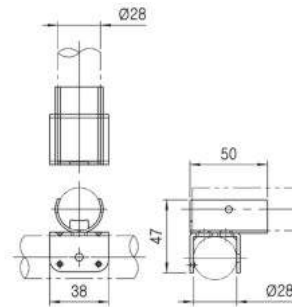

GS-D Slide Pipe Mount / Drop Stop



Material	Steel
Weight	0.116kg
Q'ty/Box	80pcs

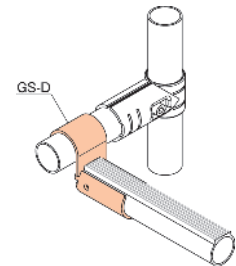
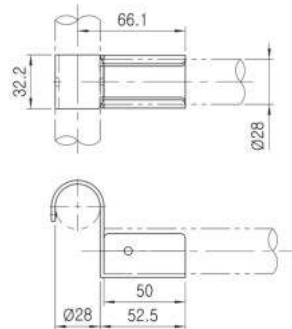

GS-D-33 Slide Pipe Mount / Drop Stop



Material	Steel
Weight	0.160kg
Q'ty/Box	80pcs

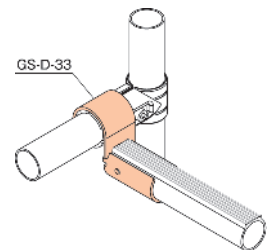
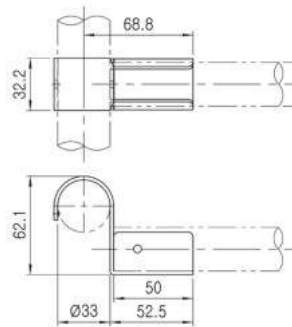

GS-E Slide Pipe Mount Guide Bracket



Material	Steel
Weight	0.160kg
Q'ty/Box	30pcs

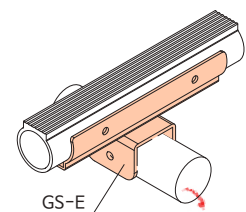
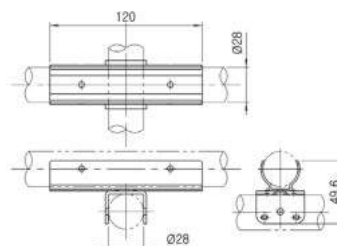

SLIDE PIPE MOUNTING BRACKETS

* Surface Treatment - WZ

Unit : mm

GS-F Box Guide Mount Bracket



Material	Steel
Weight	0.150kg
Q'ty/Box	36pcs

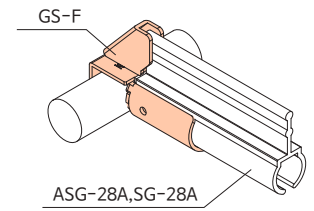
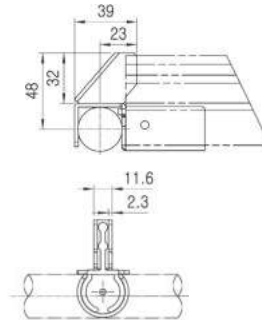

GS-F40 Box Guide Mount Bracket



Material	Steel
Weight	0.180kg
Q'ty/Box	36pcs

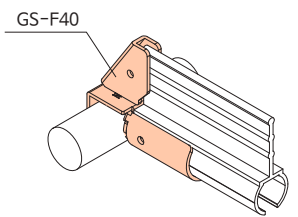
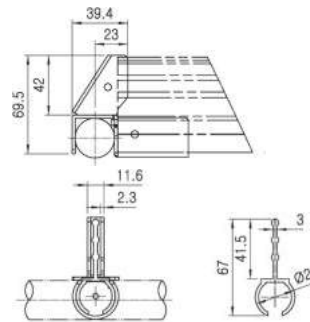

GS-HP Slide Pipe Mount



Material	Steel
Weight	0.155kg
Q'ty/Box	50pcs

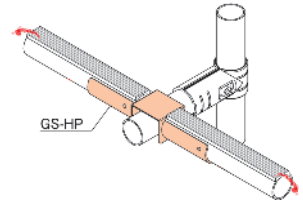
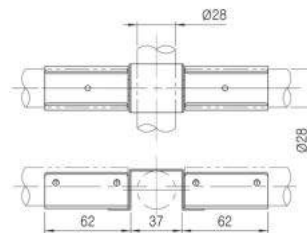

GS-11 Adjustable Slide Pipe Union



Material	Steel
Weight	0.073kg
Q'ty/Box	150pcs

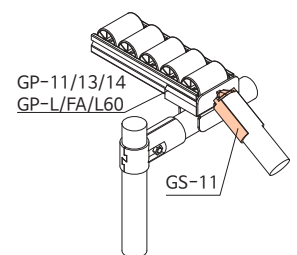
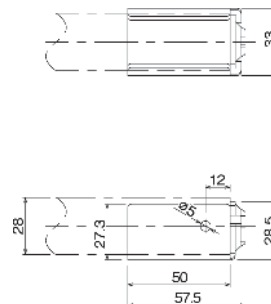

BOX GUIDE

Unit : mm

SG-28A Box Guide



Material	PVC
Length	3,000mm
Weight	0.420kg/m

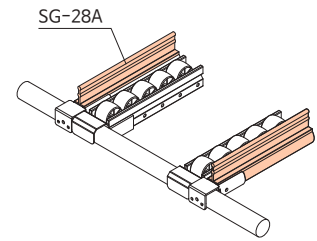
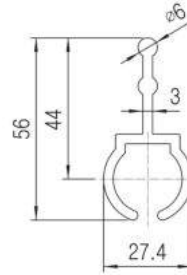

SG-2860A Box Guide



Material	PVC
Length	3,000mm
Weight	0.570kg/m

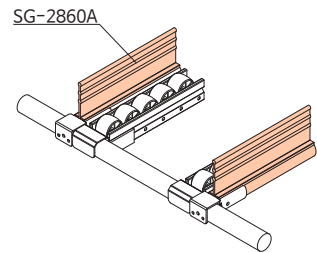
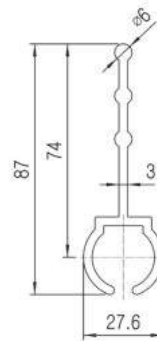

RG-35B Box Guide



Material	PVC
Length	3,000mm
Weight	0.860kg/m

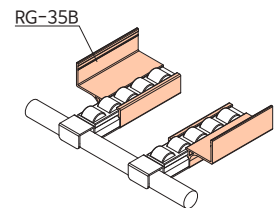
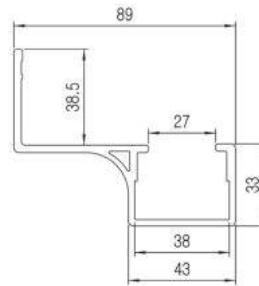

RG-40A Box Guide



Material	PVC
Length	3,000mm
Weight	0.500kg/m

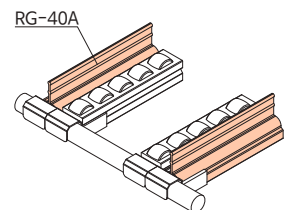
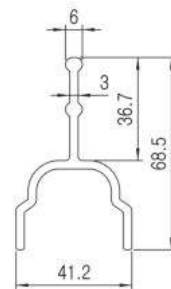

RG-40B Box Guide



Material	PVC
Length	3,000mm
Weight	0.970kg/m

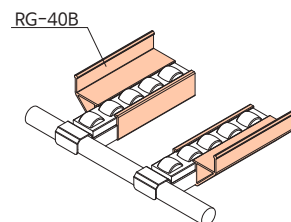
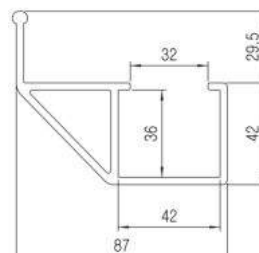

BOX GUIDE

Unit : mm

RG-40B40 Box Guide



Material	PVC
Length	3,000mm
Weight	1.400kg/m

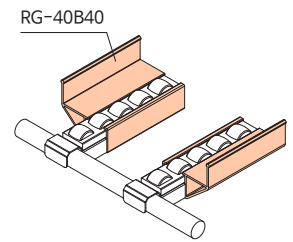
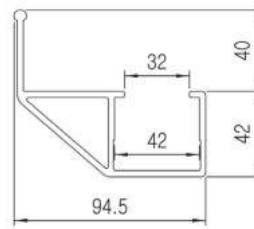

RG-40C Box Guide



Material	PVC
Length	3,000mm
Weight	0.700kg/m

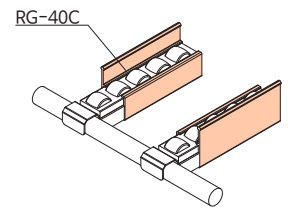
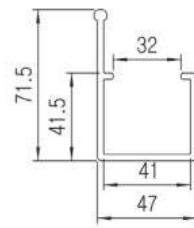

RG-40D Box Guide



Material	PVC
Length	3,000mm
Weight	570kg/m

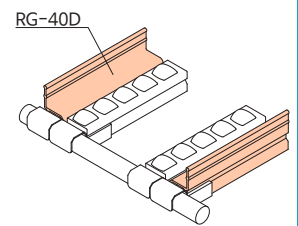
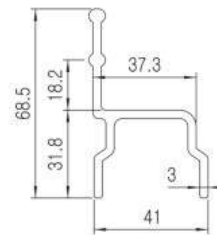

RG-40E Box Guide



Material	PVC
Length	3,000mm
Weight	0.860kg/m

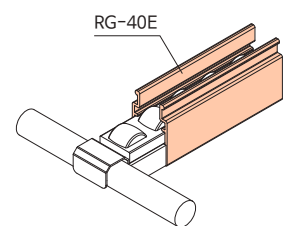
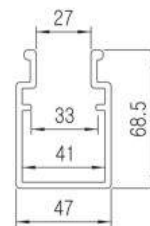

SG-01 Sheet Guide



Material	PVC
Length	3,000mm
Weight	0.450kg/m

Use 5mm thickness board panel

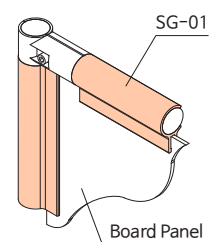

BOX GUIDE

Unit : mm

SG-02 Sheet Guide



Material	PVC
Length	3,000mm
Weight	0.740kg/m

Use 5mm thickness board panel

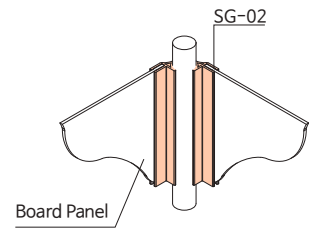
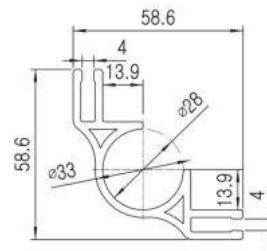

SG-03 Sheet Guide



Material	PVC
Length	3,000mm
Weight	0.490kg/m

Use 5mm thickness board panel

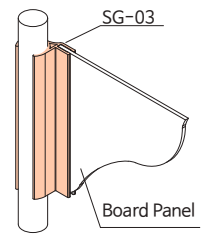
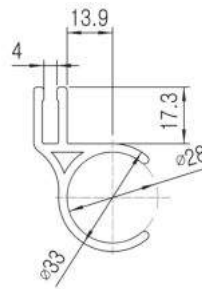

CD-28C Cable Duct



Material	PVC
Length	3,000mm
Weight	0.260kg/m

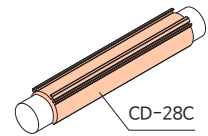
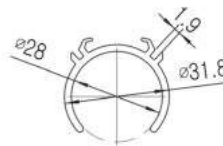

CD-28D Cable Duct



Material	PVC
Length	3,000mm
Weight	0.220kg/m

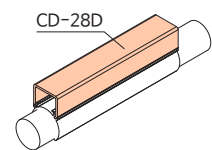
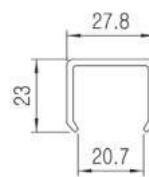

DP-A Dust Plate



Material	PVC
Length	3,000mm
Weight	0.360kg/m

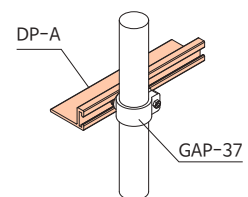
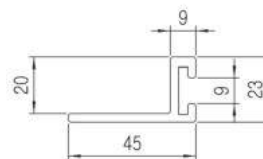

BOX GUIDE

Unit : mm



AHRG-35B Box Guide-ESD



Material	Aluminum
Length	4,000mm
Weight	1.08kg/m

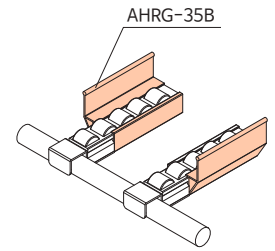
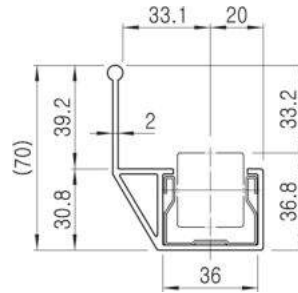

AHRG-40B Box Guide-ESD



Material	Aluminum
Length	4,000mm
Weight	1.85kg/m

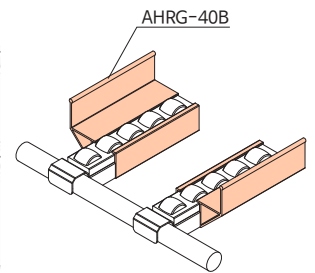
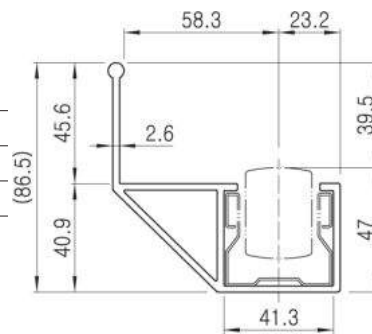

AHRG-60B Box Guide-ESD



Material	Aluminum
Length	4,000mm
Weight	1.18kg/m

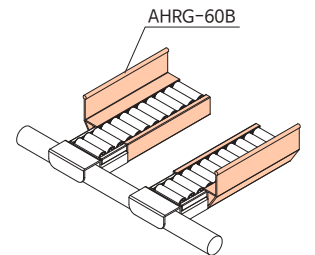
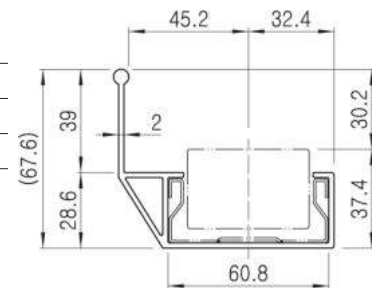

ARG-35B Box Guide-ESD



Material	Aluminum
Length	4,000mm
Weight	0.79kg/m

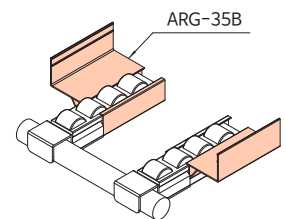
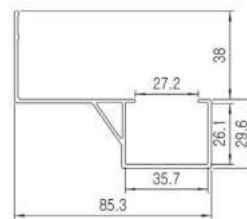

ARG-35BN Box Guide-ESD



Material	Aluminum
Length	4,000mm
Weight	0.81kg/m

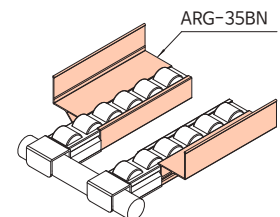

BOX GUIDE

Unit : mm

ARG-35C Box Guide-ESD



Material	Aluminum
Length	4,000mm
Weight	0.52kg/m

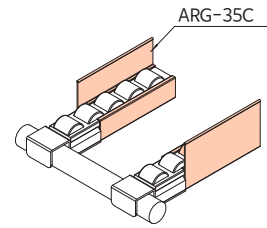

ARG-40A Box Guide-ESD



Material	Aluminum
Length	4,000mm
Weight	0.53kg/m

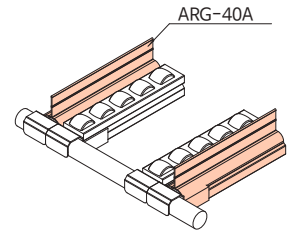
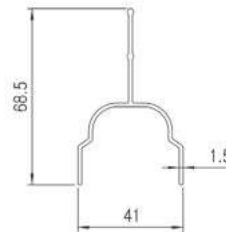

ARG-4030BL Box Guide-ESD



Material	Aluminum
Length	4,000mm
Weight	0.87kg/m

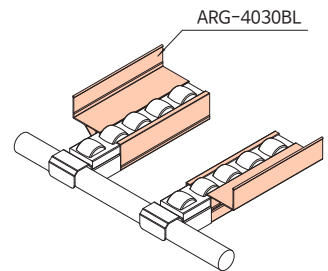
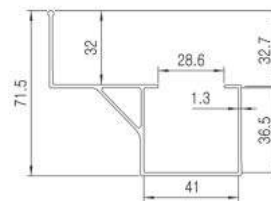

ARG-4032AN Box Guide-ESD



Material	Aluminum
Length	4,000mm
Weight	0.67kg/m

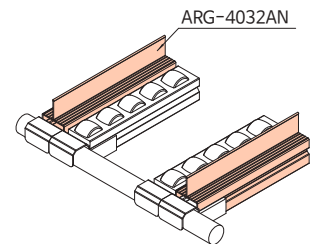
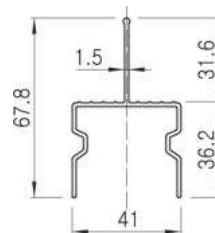

ARG-4032BN Box Guide-ESD



Material	Aluminum
Length	4,000mm
Weight	0.63kg/m

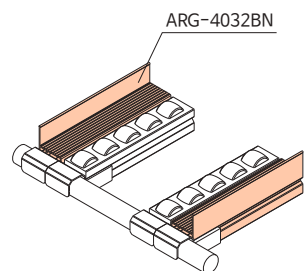
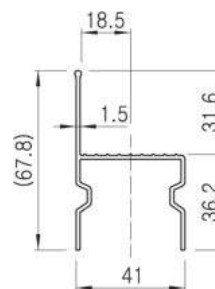

BOX GUIDE

Unit : mm

ARG-4035BS Box Guide-ESD (For GP-4035BS)



Material	Aluminum
Length	4,000mm
Weight	0.82kg/m

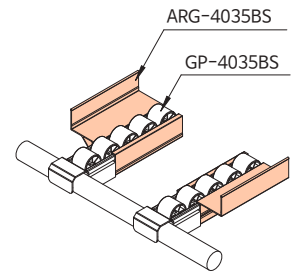
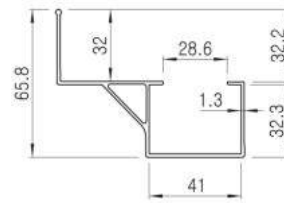

ARG-4045B Box Guide-ESD



Material	Aluminum
Length	4,000mm
Weight	0.91kg/m

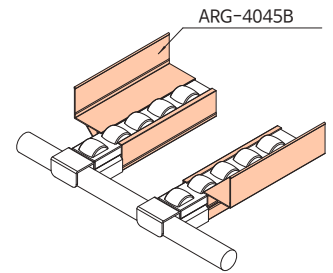
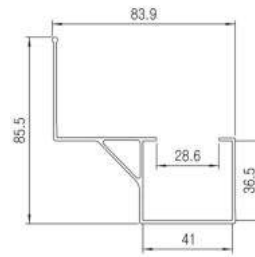

ARG-40C Box Guide-ESD



Material	Aluminum
Length	4,000mm
Weight	0.62kg/m

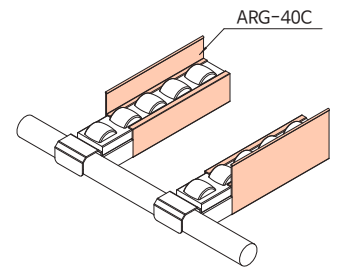
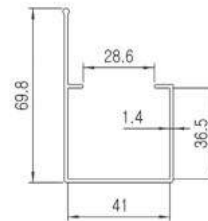

ARG-40D Box Guide-ESD



Material	Aluminum
Length	4,000mm
Weight	0.52kg/m

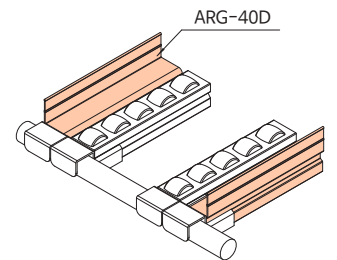
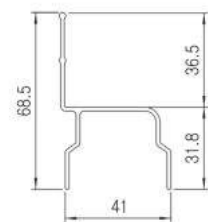

ARG-40F Box Guide-ESD



Material	Aluminum
Length	4,000mm
Weight	1.11kg/m

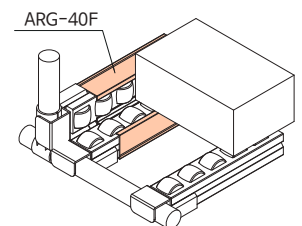
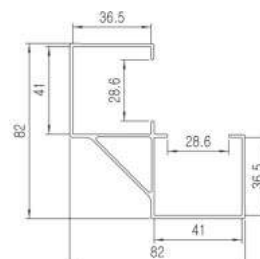

BOX GUIDE

Unit : mm

ARG-60C Box Guide- ESD



Patented

Material	Aluminum
Length	4,000mm
Weight	0.59kg/m

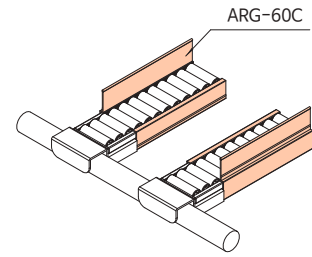
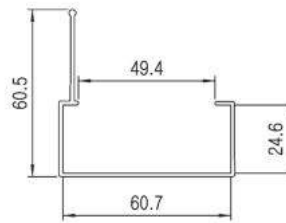

ASG-28A Box Guide - ESD



Material	Aluminum
Length	4,000mm
Weight	0.380kg/m

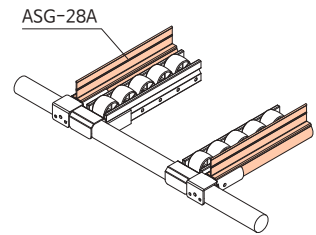
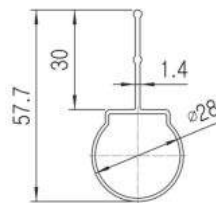

ASG-28B Box Guide-ESD



Material	Aluminum
Length	4,000mm
Weight	0.82kg/m

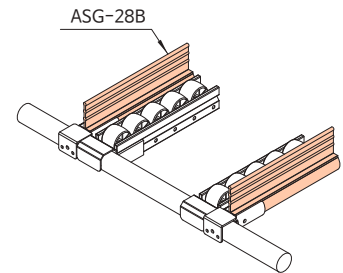
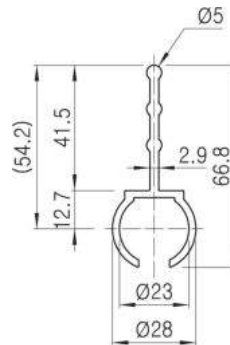

ASG-28C Box Guide-ESD



Material	Aluminum
Length	4,000mm
Weight	0.71kg/m

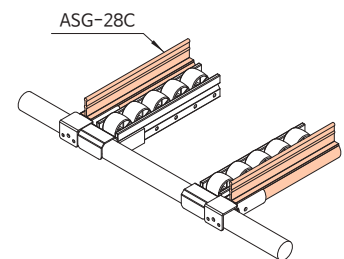
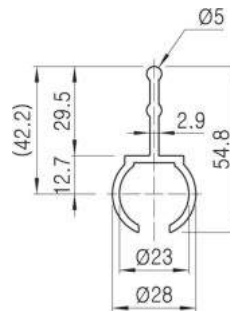

BOX GUIDE CAP

Unit : mm

ASC-V30 Vertical Safety Cap

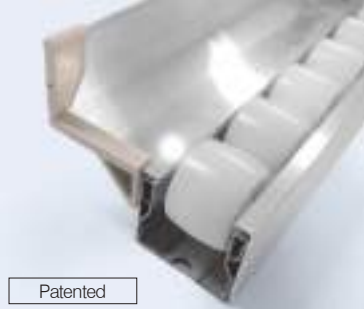

Material	ABS
Weight	0.001kg
Q'ty/Box	6,000 EA

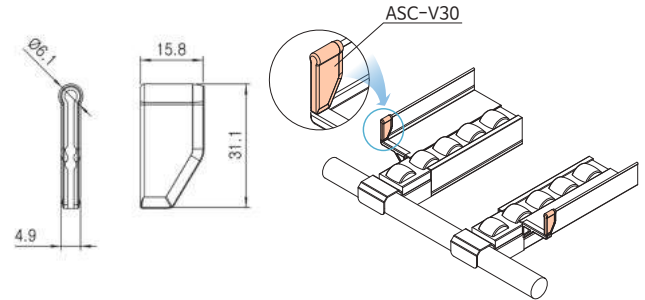

ASC-V45 Vertical Safety Cap



Material	ABS
Weight	0.002kg
Q'ty/Box	4,000 EA

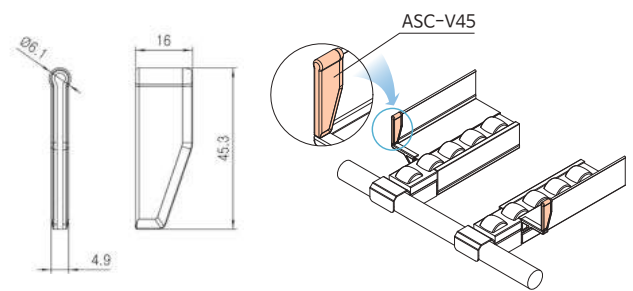

ASC-H42R Horizontal Safety Cap



Material	ABS
Weight	0.002kg
Q'ty/Box	4,000 EA

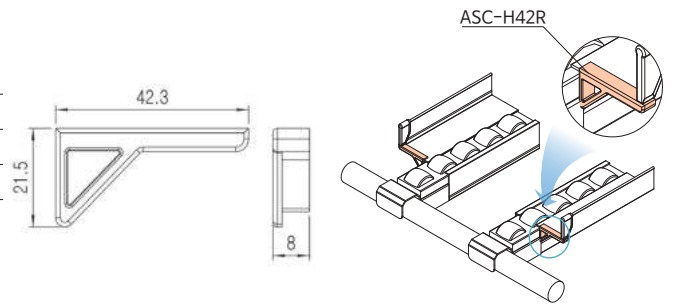

ASC-H42L Horizontal Safety Cap



Material	ABS
Weight	0.002kg
Length	4,000 EA

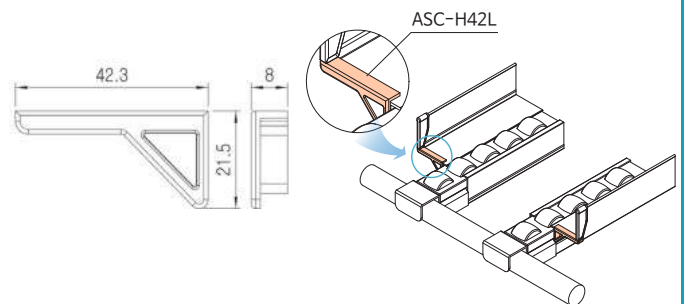

BOX STOPPER

Unit : mm

EWS-() WORK STOPPER

STANDARD TYPE (Material-STs)



Part No.	Material	Roller Track	Roller	Weight	Q'ty/Box
EWS-A	STs	GP4036A/4036B	5	0.056kg	240pcs
EWS-B		GP4050C	4	0.041kg	300pcs
EWS-C		GP8550B	4	0.136kg	70pcs
EWS-D		GP4050D	4	0.061kg	160pcs
EWS-E		GP3533B	5	0.036kg	320pcs
EWS-F		GP6033B	5	0.085kg	170pcs
EWS-F2		GP6033B	2	0.046kg	110pcs
EWS-G		GP4040A/B	4	0.085kg	240pcs
EWS-G2		GP4040A/B	2	0.036kg	140pcs
EWS-H		GP7040B/8540L	5	0.130kg	120pcs
EWS-J		GP6016S	10	0.078kg	200pcs
EWS-J2		GP6016S	5	0.050kg	250pcs
EWS-K		GP8543B/HA	4	0.140kg	90pcs

SPECIAL TYPE (Material-STs)



Part No.	Material	Roller Track	Roller	Weight	Q'ty/Box
EWS-AN	STs	GP4036A/4036B	5	0.086kg	250pcs
EWS-GN2		GP4036A/B	2	0.019kg	200pcs
EWS-GN		GP4040A/B	4	0.056kg	250pcs
EWS-MN		GPR8545B/HA	4	0.155kg	30pcs
EWS-PN		GPR2528	4	0.023kg	410pcs

RECYCLE GI BODY (Material-STs)



Part No.	Material	Roller Track	Roller	Weight	Q'ty/Box
EWSR4040	STs	GPR4040A/B	2	0.016kg	200pcs
EWSR6016		GPR6016S	4	0.018kg	200pcs
EWSR6033		GPR6033B/HA	2	0.021kg	200pcs
EWSR8523		GPR8523S	4	0.046kg	200pcs
EWSR8545		GPR8545B/HA	2	0.059kg	72pcs

Temporarily stopping the flowing Boxes

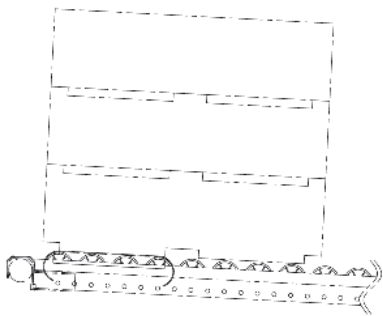

Stopping or decelerating the fast flowing Boxes



BOX STOPPER

Unit : mm

BS-01 Box Stopper



Material	Steel
Weight	1.78kg
Q'ty/Box	8pcs

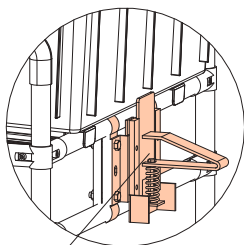
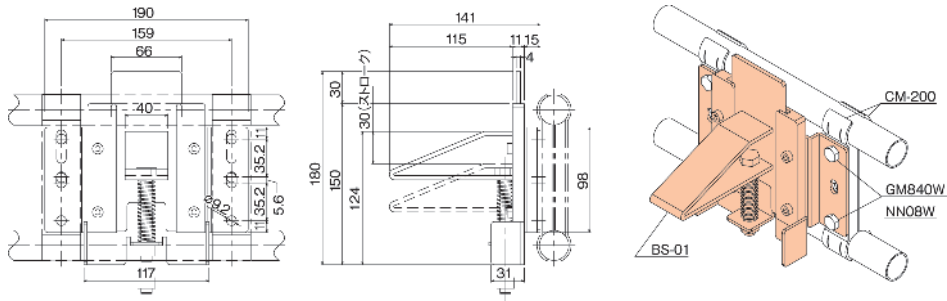

Stopper ON

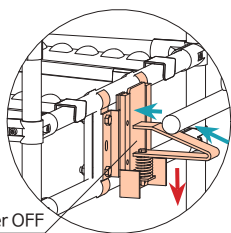

Stopper OFF

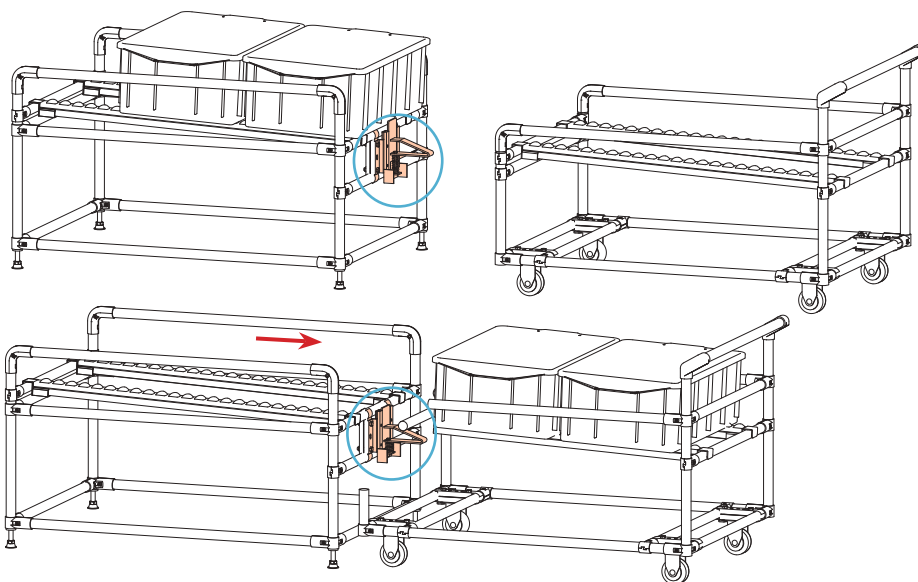

BS-15 Back Stopper Bracket



Material	Steel
Weight	0.105kg
Q'ty/Box	60 pcs

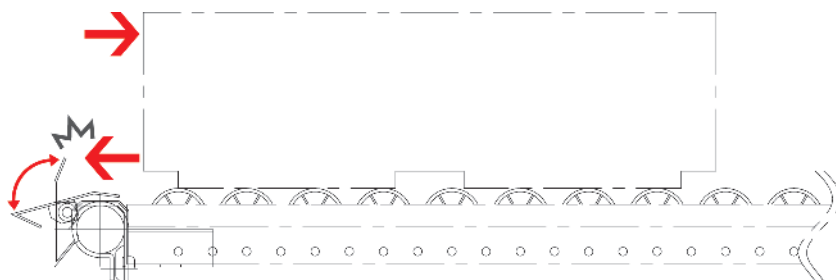
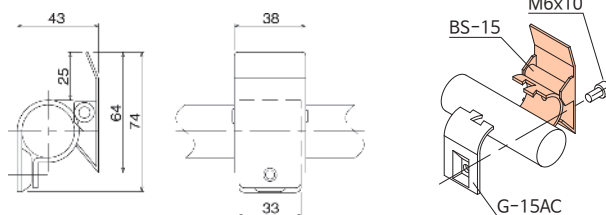

BOX STOPPER

* Surface Treatment - WZ

Unit : mm

MCY-A301 One Touch Stopper -Right



Material	Steel
Weight	0.270kg
Q'ty/Box	36pcs

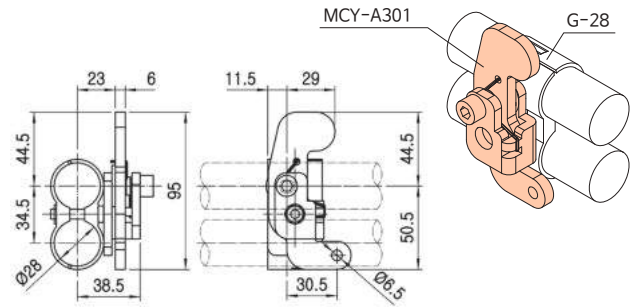

Single Mount

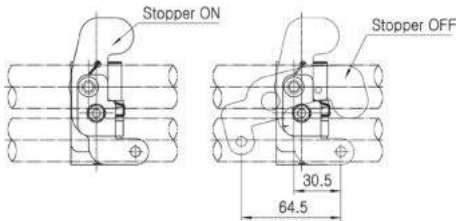

Double Mount

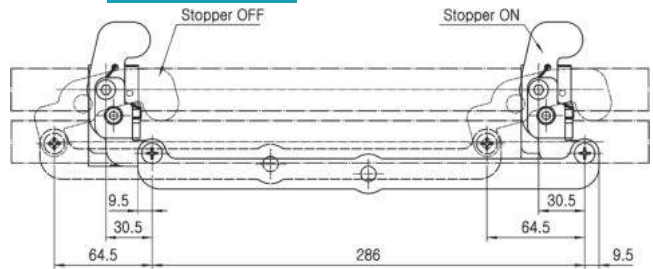

MCY-E301 One Touch Stopper -Left



Material	Steel
Weight	0.270kg
Q'ty/Box	36pcs

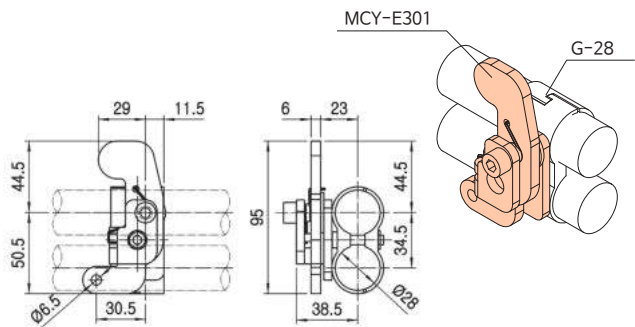

Single Mount

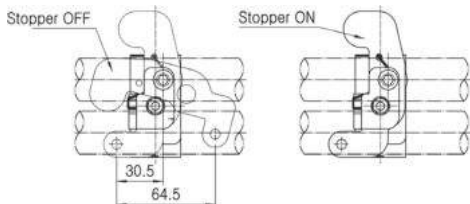

Double Mount

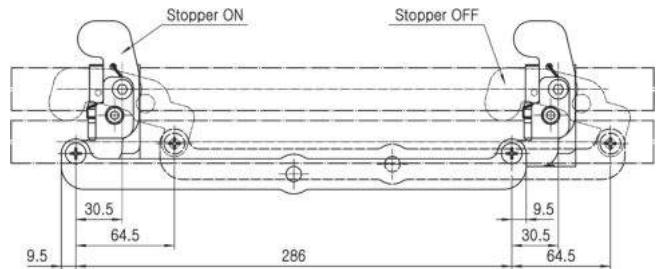

Explode View

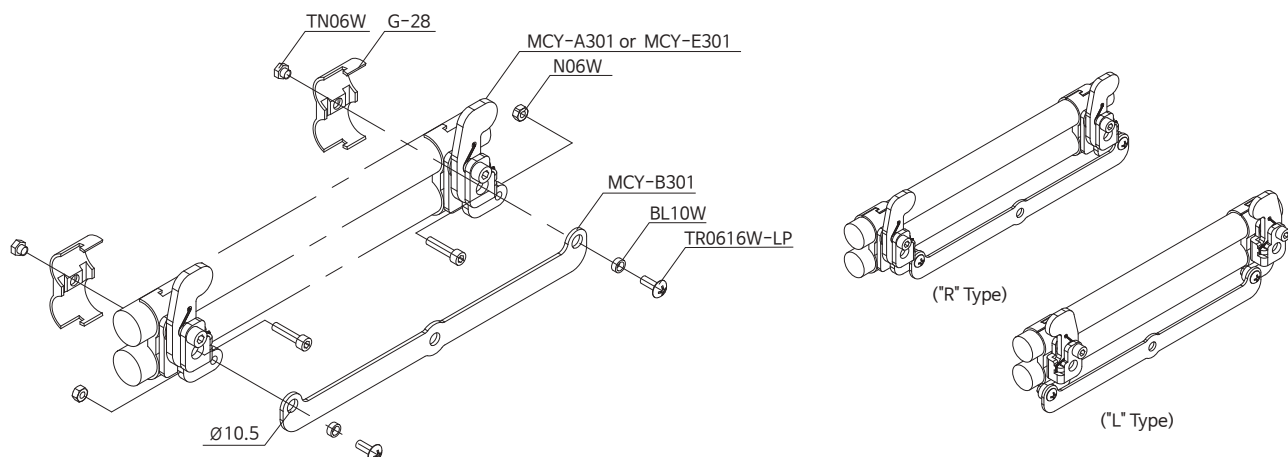

BOX STOPPER

* Surface Treatment - WZ

Unit : mm



MCY-305A Back Stopper Bracket



Material	Steel
Weight	0.213kg
Q'ty/Box	30pcs

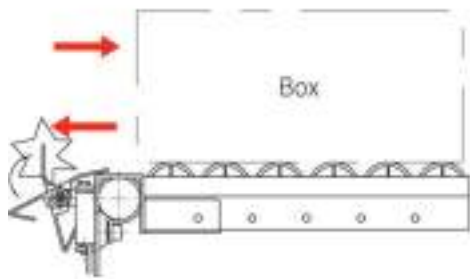
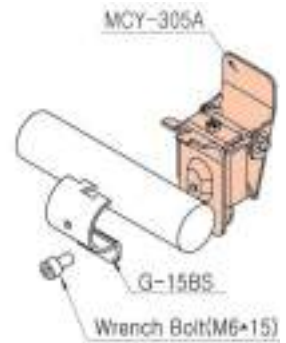
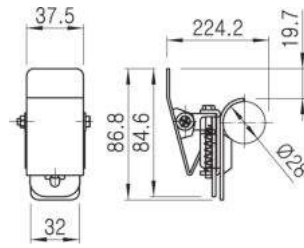

Stopping Backflow

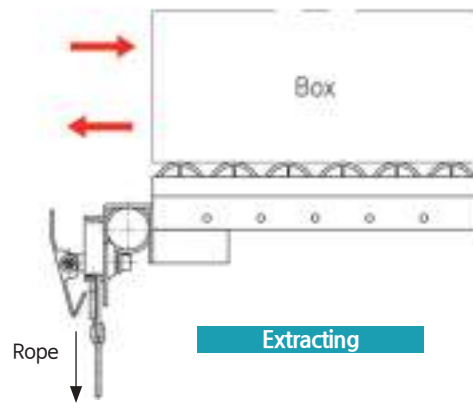

Extracting

ROLLER TRACKS

QS-28 Quick Stopper



Material	Steel
Weight	0.370kg
Q'ty/Box	18pcs

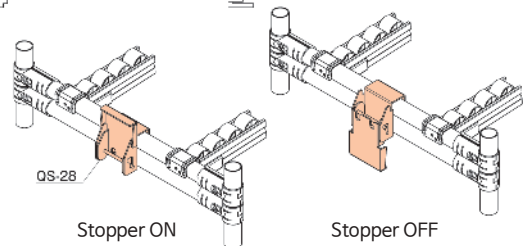
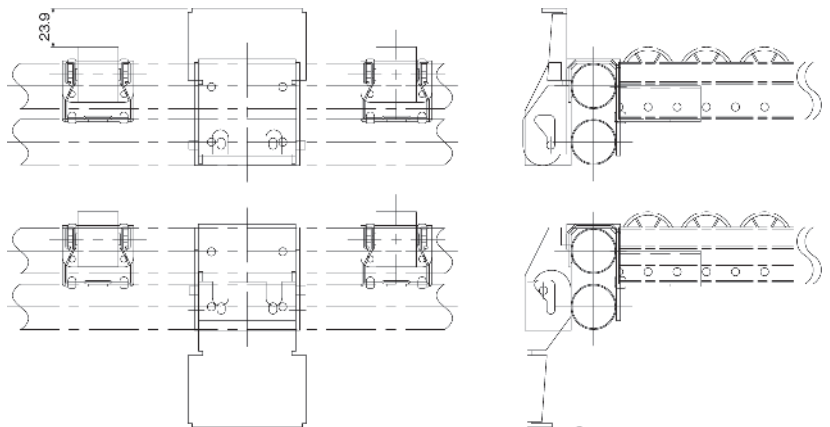

CASTERS

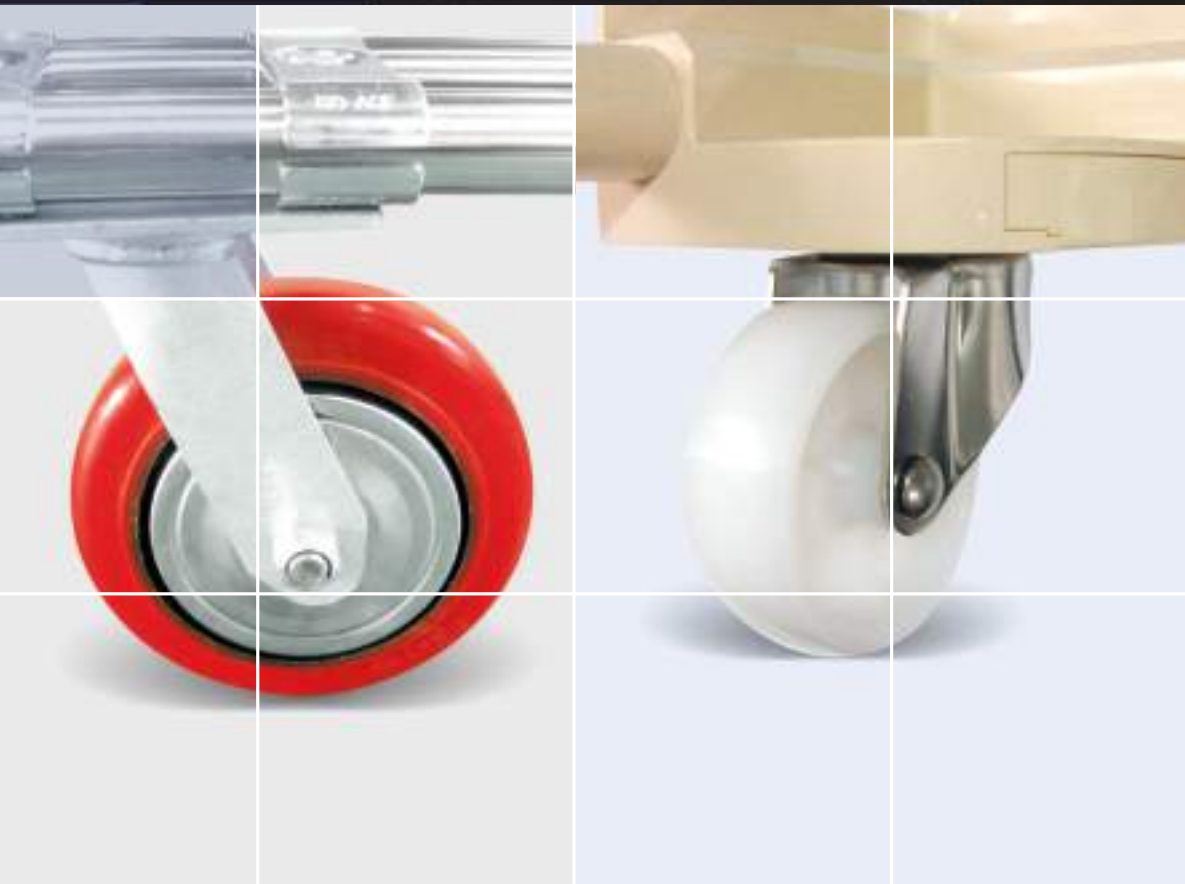

- CASTER
 - THREADED STEM TYPE
 - GRIP RING TYPE
 - FASTENING RUBBER TYPE
 - TOP PLATE TYPE
- AL CASTER
 - FASTENING RUBBER TYPE
 - TOP PLATE TYPE
- FLOOR LOCK

CASTER

CASTERS NUMBERING SYSTEMS

T 36 3 S - 1 B

Stem Type	Series No.	Wheel Size	Type	Wheel Material	Brake
T : Thread G : Grip Ring F : Fastening Rubber P : Top Plate Type	30 32 36 50 60 62 68	2-2" 2.5-2.5" 3-3" 3.5-3.5" 4-4" 6-6" 8-8"	S : Swivel R : Rigid	1 : Soft Rubber 2 : Polyurethane(Red) 3 : Nylon 4 : Rubber Plastic 5 : Polyurethane(Gray) E : ESD	B : Brake DB : Double Brake S : Stainless BS : STS Brake

THREADED STEM TYPE

Design



Part No.			Wheel Dia (Inch)	Wheel Material	Inch(mm)	Section	Threaded Specification		
SWIVEL	BRAKE	ESD							
T302S-1	T302S-1B	T302S-E	2"	Soft Rubber	20	Light	1/2" x12N-15L		
T3625S-1	T3625S-1B	T3625-E	2.5"	Soft Rubber	25			99	
T3625S-2	T3625S-2B	-		Polyurethane					45
T3625S-4	T3625S-4B	-		Rubber Plastic					40
T363S-1	T363S-1B	T363S-E	3"	Soft Rubber	25	99	1/2" x12N-15L		
T363S-3	T363S-3B	-		Nylon				65	
T363S-4	T363S-4B	-		Rubber Plastic				55	

Wheel



CASTER

THREADED STEM TYPE

Design



Part No.			Wheel Dia (inch)	Wheel Material	Inch(mm)	Ball	kg	mm<A>	Section	Threaded Specification
SWIVEL	BRAKE	ESD								
T503S-1	T503S-1B	T503S-E	3"	Soft Rubber	32	Ball	56	104	Light	1/2" x12N-25L
T503S-2	T503S-2B	-		Polyurethane			100			
T504S-1	T504S-1B	T504S-E	4"	Soft Rubber			75	129		
T504S-2	T504S-2B	-		Polyurethane			100			

Wheel



GRIP RING TYPE

Design



Part No.			Wheel Dia (inch)	Wheel Material	Inch(mm)	Plain	kg	mm<A>	Section	Threaded Specification
SWIVEL	BRAKE	RIGID								
G813S-2	G813S-2B	G813R-2	3"	Polyurethane	32	Plain	75	100	Light	φ 11 X 38mm

Assembly : Pipe + GAP-9 + Grip Ring Caster

GAP-9C

Coated Pipe (φ 28XT1.0)

GAP-9S

STS/Eco Pipe (φ 28XT0.7)

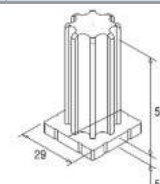

CASTER

FASTENING RUBBER TYPE

Design



Pipe	Part No.			Wheel Dia (inch)	mm	Wheel Type	kg	<A>
	SWIVEL	BRAKE	RIGID					
Coated Pipe	FC302S-1	FC302S-1B	-	2"	20	Plain	35	72
	FC303S-1	FC303S-1B	-	3"			45	97
	FC363S-1	FC363S-1B	-	3"	25	Plain / Ball	45	99
	FC363S-4	FC363S-4B	FC363R-4			Ball	50	99
	FC364S-1	FC364S-1B	FC364R-1	4"	25	Plain / Ball	55	123
	FC364S-4	FC364S-4B	FC364R-4			Ball	60	123
	FC503S-1	FC503S-1B	-	3"	32	Plain	56	104
	FC504S-2	FC504S-2B	-	4"			85	129
	FCD374S-1	FCD374S-1B	-	4"	20	Disc	55	124
STS/ECO Pipe	FS302S-1	FS302S-1B	FS302R-1	2"	20	Plain	35	72
	FS303S-1	FS303S-1B	FS303R-1	3"			45	97
	FS363S-1	FS363S-1B	-	3"	25	Plain / Ball	45	99
	FS363S-4	FS363S-4B	FS363R-4			Ball	50	99
	FS364S-1	FS364S-1B	FS364R-1	4"	25	Plain / Ball	55	123
	FS364S-4	FS364S-4B	FS364R-4			Ball	60	123
	FS503S-1	FS503S-1B	-	3"	32	Plain	56	104
			FS504R-2	4"			85	129
	FSD374S-1	FSD374S-1B	-	4"	20	Disc	55	124

* FASTENING RUBBER TYPE : ESD is available

Remark	Wheel Material : Soft Rubber (Normal) / ESD Soft Rubber	FC : Fastening Rubber-Coated Pipe (φ28 x T0.7 / T1.0) FS : Fastening Rubber-STS/Eco Pipe (φ28 x T0.7 / T1.2)
--------	---	---

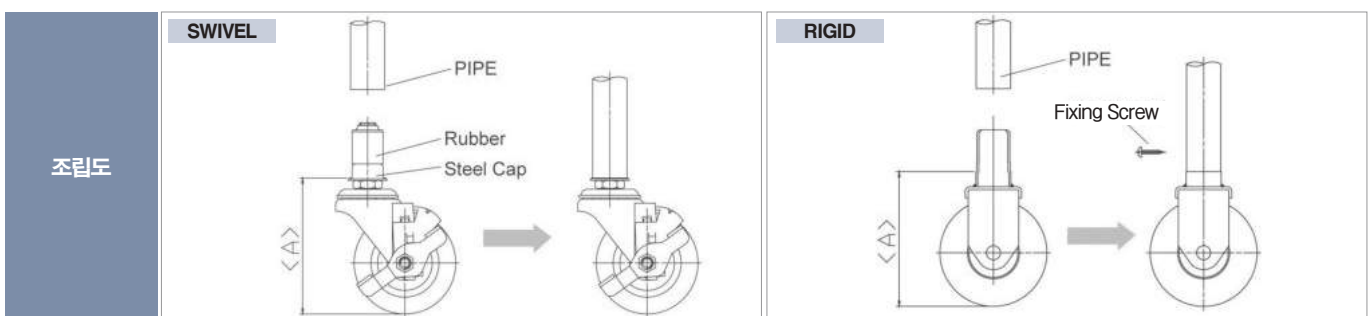

CASTER

TOP PLATE TYPE

Design



Part No.				Wheel Dia (inch)	Wheel Material	mm	Plain	kg	mm	Plate Dimension(mm)	
SWIVEL	BRAKE	DOUBLE BRAKE	RIGID							Overall <D×E>	Hole <B×C>
P363S-3S (All Stainless)	-	-	-	3"	Nylon	25	Plain	65	95	70X60	55X42
P363S-3 (Steel)	-	-	-								
P503S-1	P503S-1B	P503S-1DB	P503R-1	3"	Soft Rubber	32	Ball	56	104	95X64	75X45
P503S-2	P503S-2B	P503S-2DB	P503R-2		Polyurethane			100			
P504S-1	P504S-1B	P504S-1DB	P504R-1	4"	Soft Rubber	32	Ball	75	129	95X64	75X45
P504S-2	P504S-2B	P504S-2DB	P504R-2		Polyurethane			105			
P505S-1	P505S-1B	P505S-1DB	P505R-1	5"	Soft Rubber	32	Ball	80	156	95X64	75X45
P505S-2	P505S-2B	P505S-2DB	P505R-2		Polyurethane			115			

※ P503 / P504 / P505 Series : ESD is available

Wheel



CASTER

TOP PLATE TYPE

Design



Part No.			Wheel Dia (inch)	Wheel Material	mm	Roller	kg	mm	Plate Dimension(mm)	
SWIVEL	BRAKE	RIGID							Overall <D×E>	Hole <B×C>
P624S-2	P624S-2B	P624R-2	4"	Polyurethane	38	Roller	220	136	114X101	80X76
P625S-2	P625S-2B	P625R-2	5"				250	161		
P626S-2	P626S-2B	P626R-2	6"				250	191		
P664S-2	P664S-2B	P664R-2	4"	Polyurethane	50	Roller/ Ball	320	143	114X101	80X76
P665S-2	P665S-2B	P665R-2	5"				360	165		
P666S-2	P666S-2B	P666R-2	6"				360	187		
P686S-2	P686-2B	P686R-2	6"	Polyurethane	50	Ball	360	200	159X114	125X62
P688S-2	P688-2B	P688R-2	8"	Polyurethane	50	Roller/ Ball	400	248	159X114	125X62

※ P686 Series : Shock Absorbing Caster

Wheel

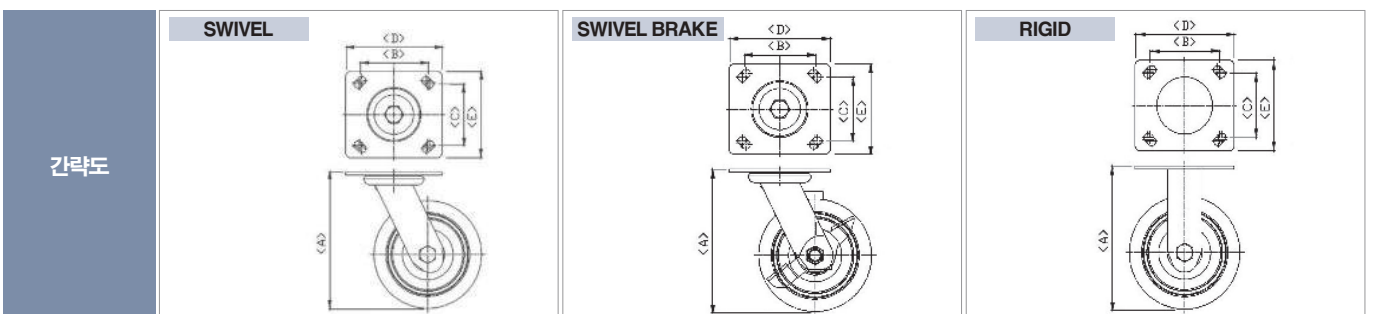
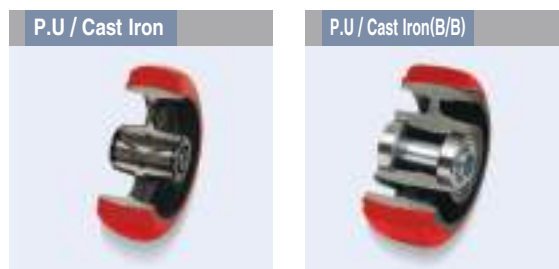

AL CASTER

CASTERS NUMBERING SYSTEMS

	FA	36	3	S	1	B
Stem Type	Series No.	Wheel Size	Type	Wheel Material	Brake	
FA : Fastening Rubber PA : Top Plate Type	30 32 36 50	2-2" 3-3" 4-4" 5-5"	S : Swivel R : Rigid	1 : Soft Rubber 2 : Polyurethane(Red) 3 : Nylon 4 : Rubber Plastic 5 : Polyurethane(Gray) E : ESD	B : Brake DB : Double Brake S : Stainless BS : STS Brake	

FASTENING RUBBER TYPE CASTER FOR AL RACK



Pipe	Part No.			Wheel Dia (inch)	mm	Wheel Type	kg	<A>
	SWIVEL	BRAKE	RIGID					
Aluminum Pipe	FA302S-1	FA302S-1B	-	2"	20	Plain	35	72
	FA303S-1	FA303S-1B	-	3"			45	97
	FA363S-1	FA363S-1B	-	3"	25	Plain / Ball	45	95
	FA363S-4	FA363S-4B	FA363R-4			Ball	50	95
	FA364S-1	FA364S-1B	FA364R-1	4"	Plain / Ball	55	123	
	FA364S-4	FA364S-4B	FA364R-4		Ball	60	123	

* FASTENING RUBBER TYPE : ESD is available

Remark	Bolt Specification : 1/2" X 13N - 57mm Wheel Material : Soft Rubber (Nomal) / ESD Soft Rubber	FA : Fastening Rubber Aluminum Pipe
---------------	--	-------------------------------------

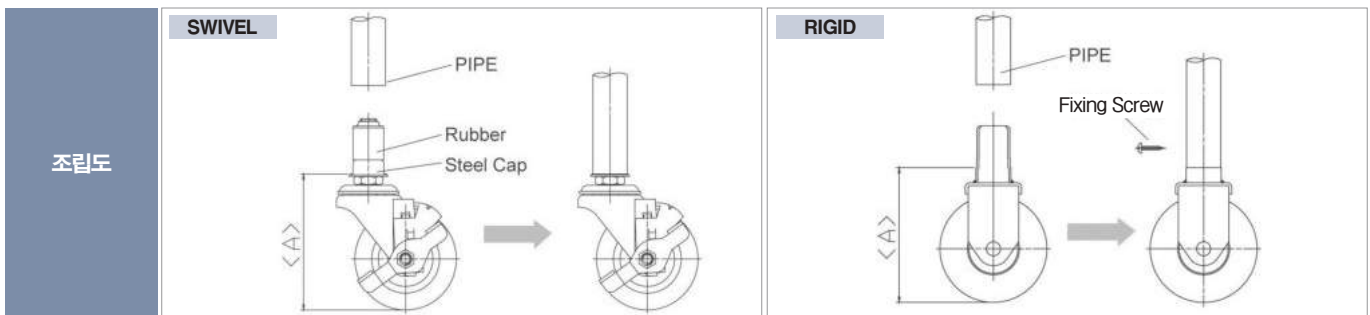

AL CASTER

TOP PLATE TYPE CASTER FOR AL RACK



Part No.			Wheel Dia (inch)	Wheel Material	mm	mm	kg	mm	Plate Dimension(mm)		
SWIVEL	BRAKE	RIGID							Overall <D×E>	Hole <B×C>	
PA503S-1	PA503S-1B	PA503R-1	3"	Soft Rubber	32	Plain	56	104	95X79	75X45	
PA503S-2	PA503S-2B	PA503R-2		Polyurethane			100				
PA504S-1	PA504S-1B	PA504R-1	4"	Soft Rubber			75				
PA504S-2	PA504S-2B	PA504R-2		Polyurethane			105				
PA505S-1	PA505S-1B	PA505R-1	5"	Soft Rubber			Ball	80			156
PA505S-2	PA505S-2B	PA505R-2		Polyurethane				115			

※ PA503 / PA504 / PA505 Series : ESD 생산가능

Wheel

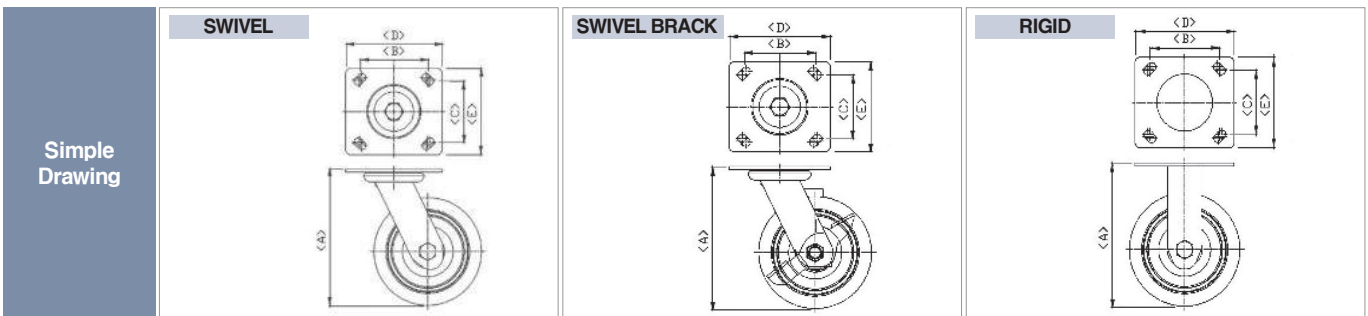

FLOOR LOCK

KH-200 (FLOOR LOCK)

Design



Item No.	Height H	Stroke K	Working height H1	Length L	Plate P	Bolt distance S	Bolt hole B	Caster height
KH-200-4	103	27	130~145	150	97X88	70 X 60	10	125~140
KH-200-5	120	27	147~172	150	97 X 88	70 X 60	10	145~165
KH-200-스텐	160	45	205~230	195	120X120	85 X 85	10	188~220
KH-200-6	160	45	205~230	195	120X120	85 X 85	11	188~220
KH-200-8	210	40	250	195	120X120	85 X 85	11	240~245

※ Please Referring the caster height to select the Floor Lock

SWIVEL

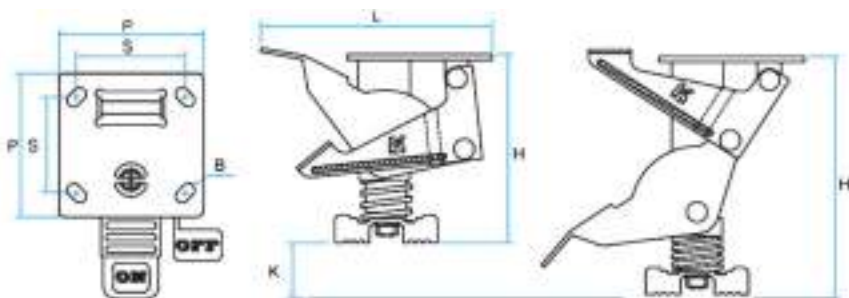

STEM

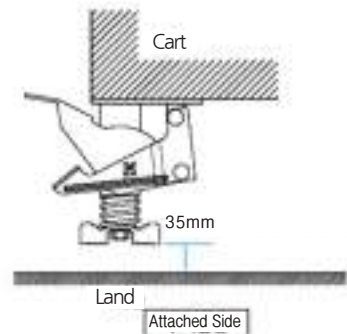

Simple Drawing

ACCESSORIES

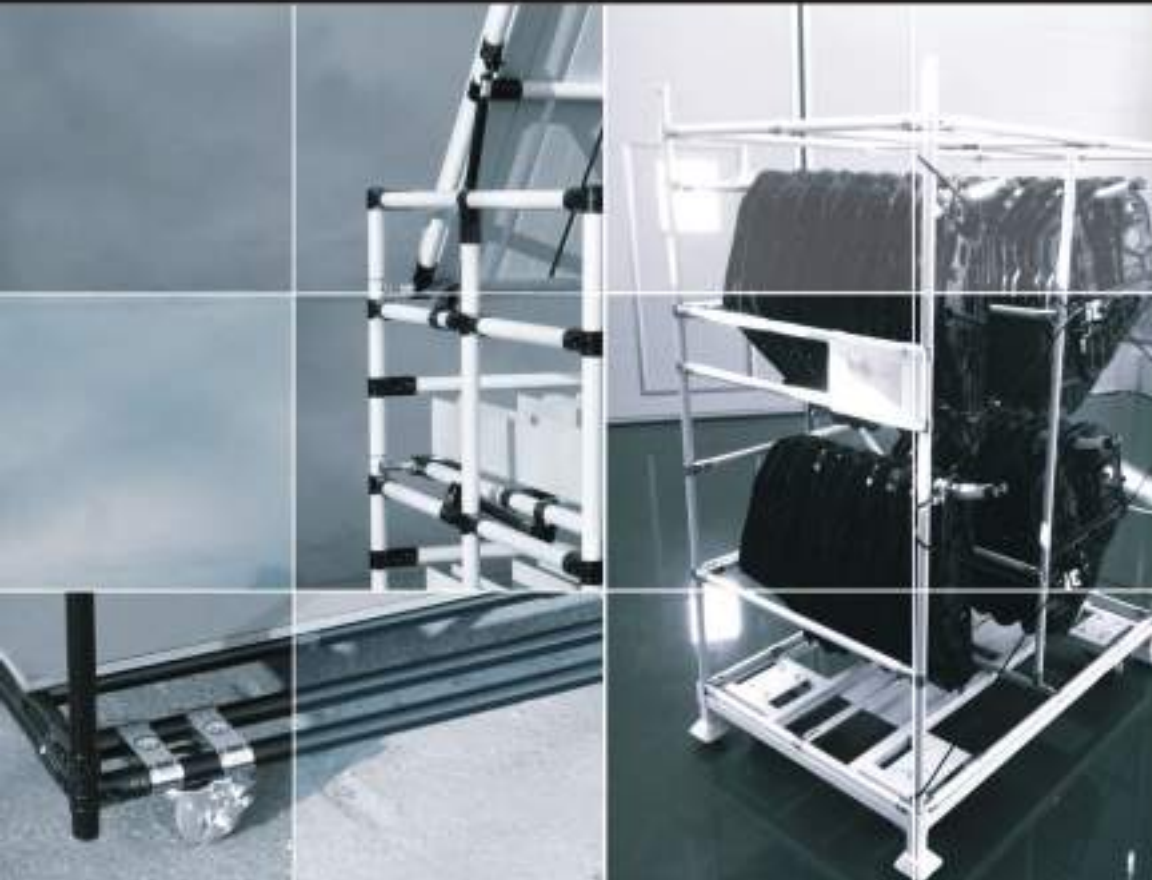

- PIPE REST & PLUG
- CASTER MOUNT & MOUNT CORNER UNIT
- FORK GUIDE & ASS'Y HAUL
- METAL CLAMP
- HOOK & HANGER & HANDLE
- METAL JOINT COVER
- TOOL HOLDER
- ASS'Y PULLEY
- NAME PLATE & LABEL CASE
- LEVELING FOOT
- THREADED INSERT & CAP
- PLASTIC CHANNEL
- FRAME GUIDE
- FASTENERS
- HAND CUTTER
- LIFT TABLE
- OTHERS

ACCESSORIES PIPE REST & PLUG

* Surface Treatment - WZ

Unit : mm

GS-1250A End Snap Rest



Material	Steel
Weight	0.100kg
Q'ty/Box	90pcs

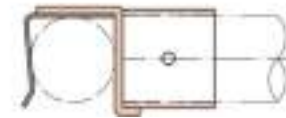
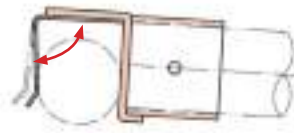
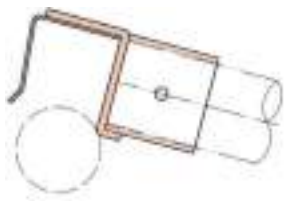
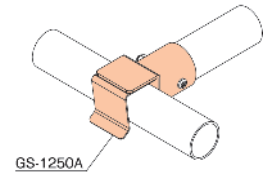
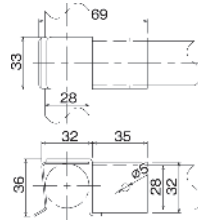

Tension

ACCESSORIES

GS-1250B End Snap Rest



Material	Steel
Weight	0.100kg
Q'ty/Box	90pcs

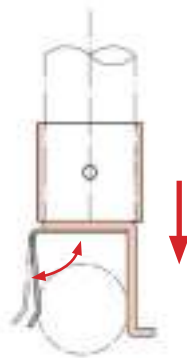
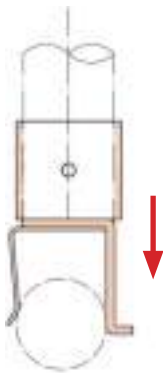
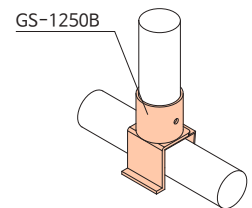
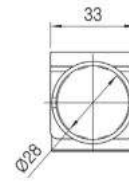
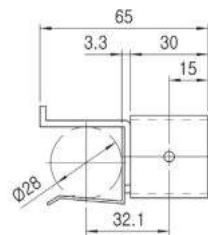

Tension

ACCESSORIES PIPE REST & PLUG

* Surface Treatment - WZ

Unit : mm

HK28WA Pipe Rest



Material	Steel
Weight	0.094kg
Q'ty/Box	90 pcs

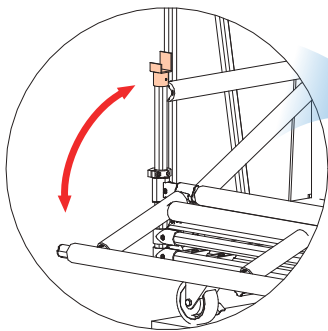
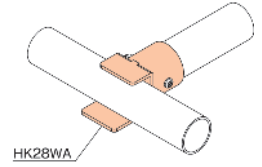
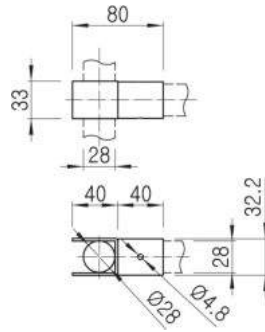

Door Open

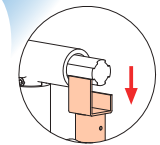
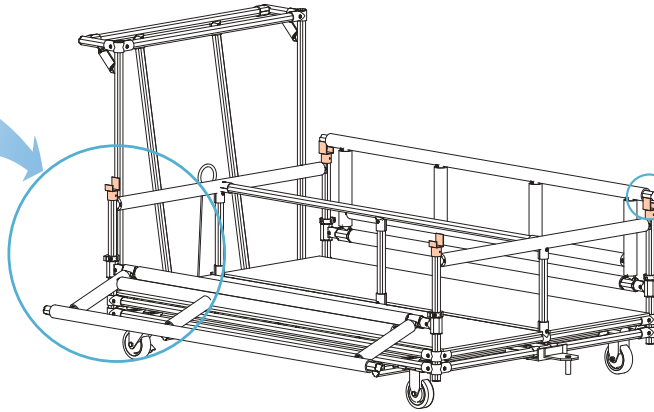

Door Locking

HK28WB Pipe Rest



Material	Steel
Weight	0.124kg
Q'ty/Box	70pcs

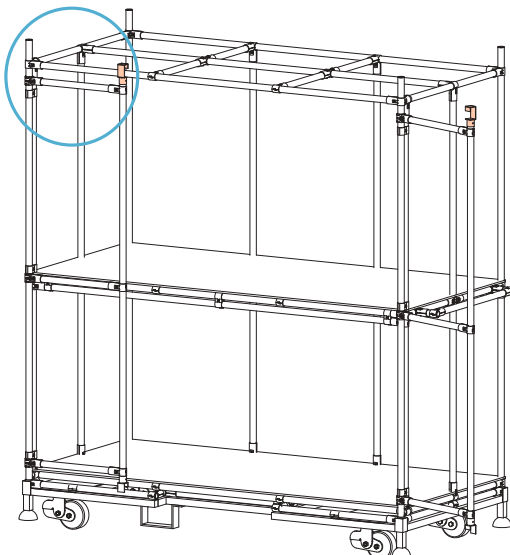
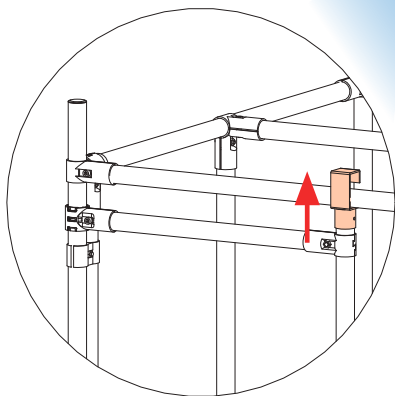
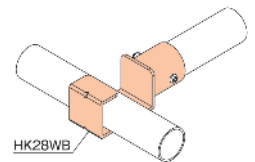
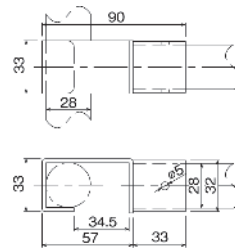

ACCESSORIES PIPE REST & PLUG

* Surface Treatment - WZ

Unit : mm

HK28WC Pipe Rest



Material	Steel
Weight	0.121kg
Q'ty/Box	90pcs

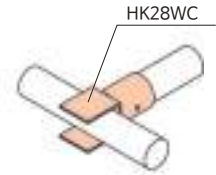

GS-2070C Pipe Plug



Material	Steel
Weight	0.120kg
Q'ty/Box	100pcs

Pipe	Thickness	Part No.
Coated	0.7	GS-2070C-C07
	0.9	GS-2070C-C09
	1.0	GS-2070C-C10
	2.0	GS-2070C-C20
STS/ ECCO	0.7	GS-2070C-S07
	0.9	GS-2070C-S10
	1.2	GS-2070C-S12

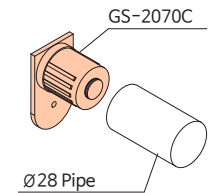
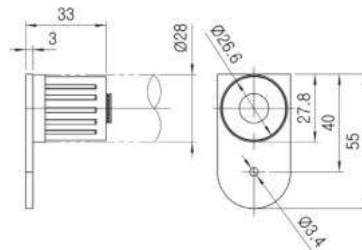

GS-2070D Slide Pipe Plug



Material	Steel
Weight	0.200kg
Q'ty/Box	90pcs

Pipe	Thickness	Part No.
Coated	0.7	GS-2070D-C07
	0.9	-
	1.0	-
	2.0	GS-2070D-C20
STS/ ECCO	0.7	GS-2070D-S07
	0.9	GS-2070D-S10
	1.2	GS-2070D-S12

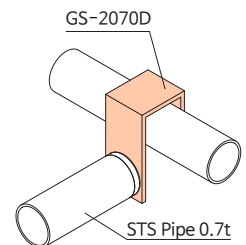
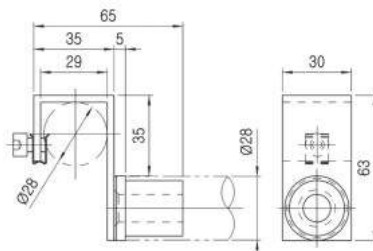

GS-2070E Slide Pipe Plug



Material	Steel
Weight	0.069kg
Q'ty/Box	100pcs

Pipe	Thickness	Part No.
Coated	0.7	-
	0.9	GS-2070E-C09
	1.0	-
	2.0	-
STS/ ECCO	0.7	-
	0.9	-
	1.2	-

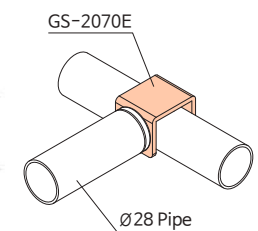
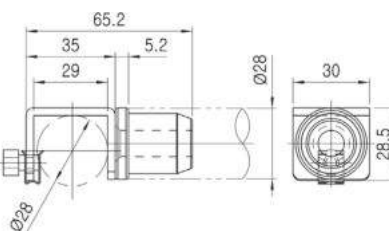

ACCESSORIES CASTER MOUNT & MOUNT CORNER UNIT

* Surface Treatment - WZ

Unit : mm

CM-100 Caster Mount Strap



Material	Steel
Weight	0.102kg
Q'ty/Box	150pcs

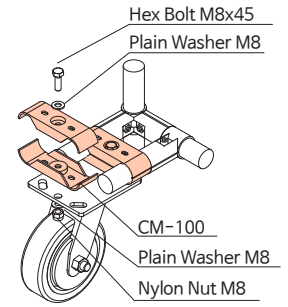
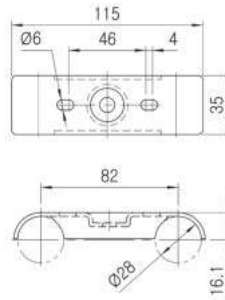

CM-200 Caster Mount Strap



Material	Steel
Weight	0.107kg
Q'ty/Box	120pcs

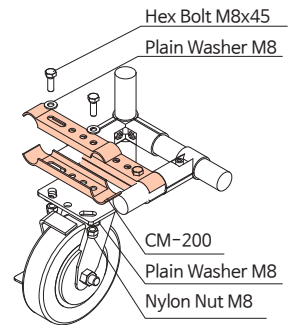
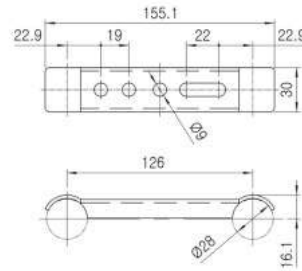

CM-200K Caster Mount Strap



Material	Steel
Weight	0.107kg
Q'ty/Box	120pcs

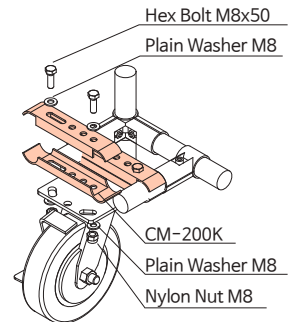
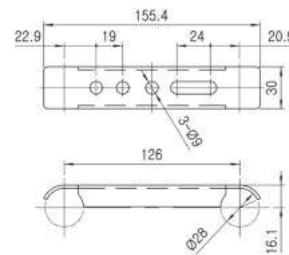

CM-230 Caster Mount Strap



Material	Steel
Weight	0.111kg
Q'ty/Box	100pcs

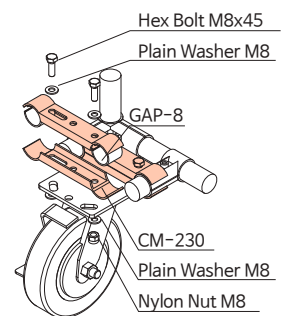
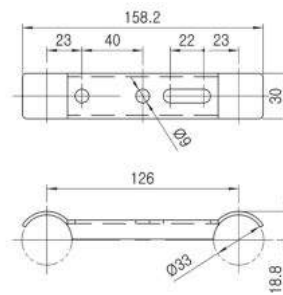

CM-230K Caster Mount Strap



Material	Steel
Weight	0.150kg
Q'ty/Box	100pcs

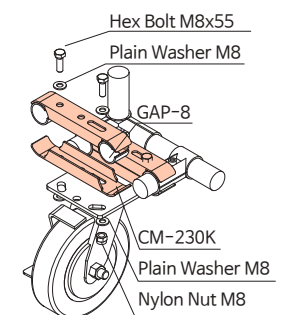
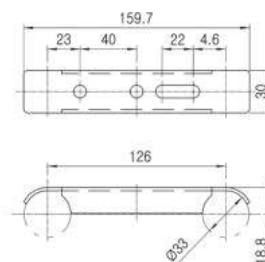

ACCESSORIES CASTER MOUNT & MOUNT CORNER UNIT

* Surface Treatment - WZ

Unit : mm

CM-300 Caster Mount Strap



Material	Steel
Weight	0.078kg
Q'ty/Box	300pcs

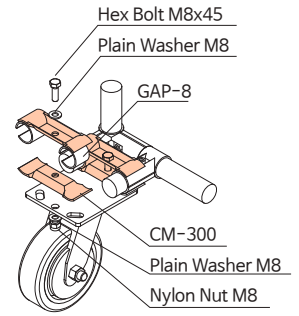
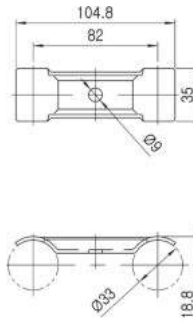

CM-330 Caster Mount Strap



Material	Steel
Weight	0.113kg
Q'ty/Box	120pcs

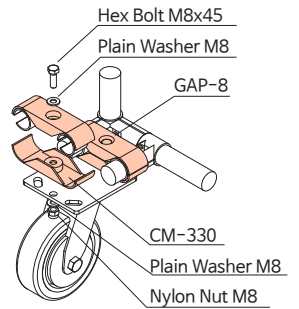
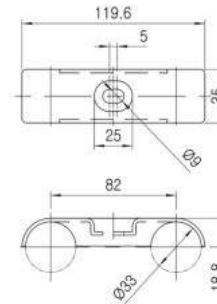

Applications of Caster Mount

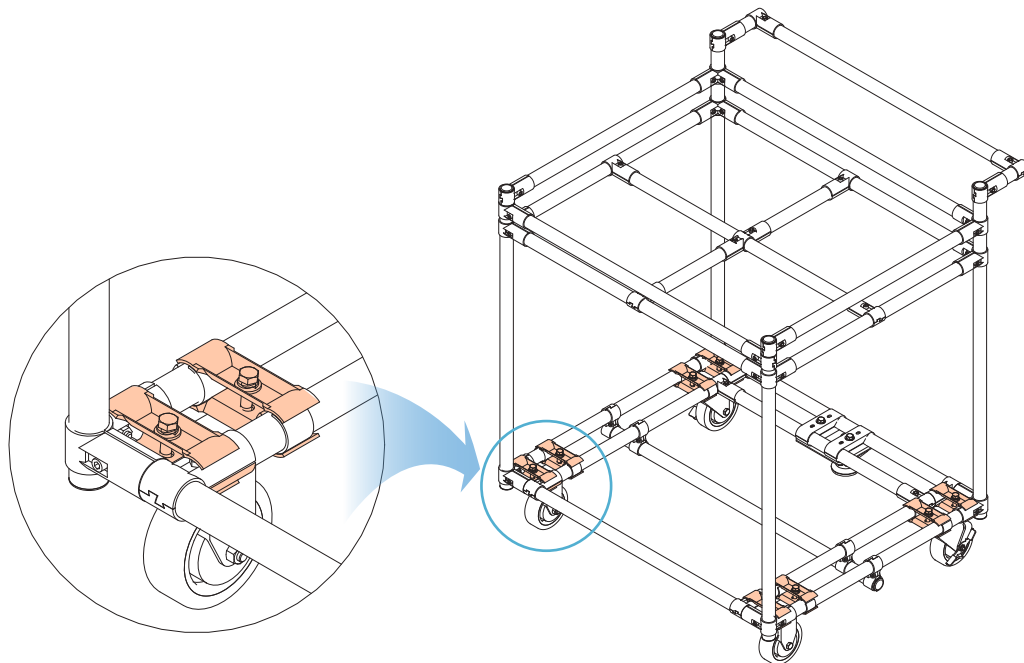

ACCESSORIES CASTER MOUNT & MOUNT CORNER UNIT

* Surface Treatment - WZ

Unit : mm

MCP-B3-L Mount Corner Plate-Left

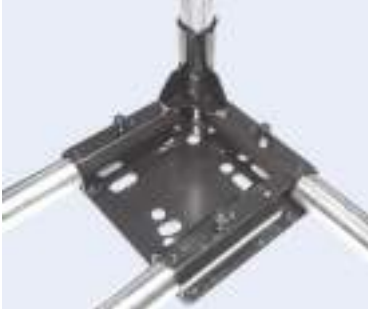

Material	Steel
Weight	1.478kg
Q'ty/Box	12pcs

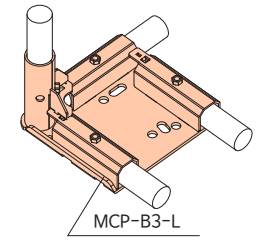
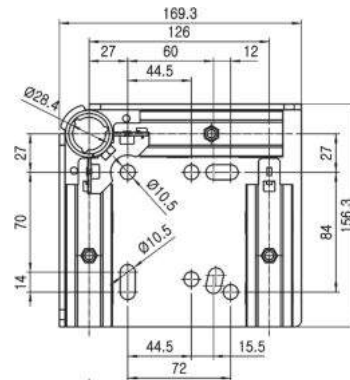

MCP-B3-R Mount Corner Plate-Right



Material	Steel
Weight	1.478kg
Q'ty/Box	12pcs

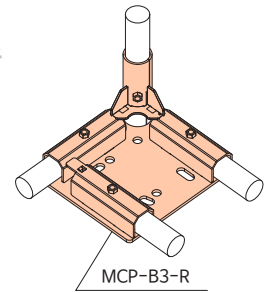
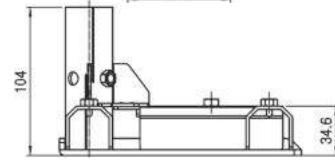

MCP-C3 Mount Center Plate



Material	Steel
Weight	1.28kg
Q'ty/Box	12pcs

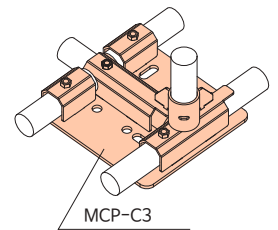
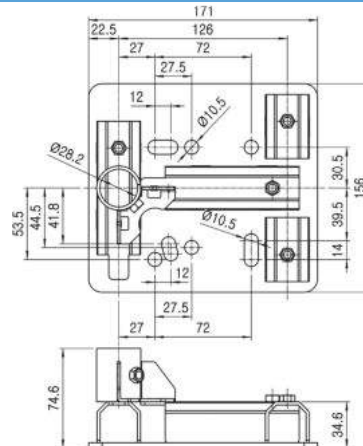

CB-MCP Corner Bumper



Material	Rubber
Weight	0.034kg
Q'ty/Box	150pcs

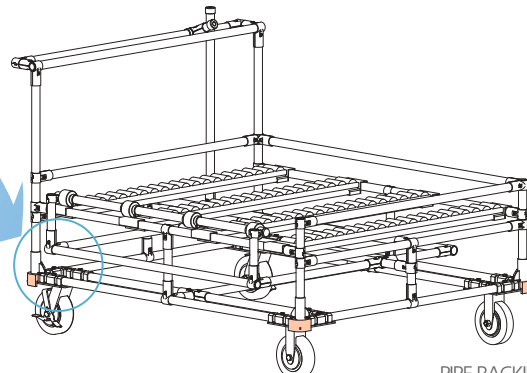
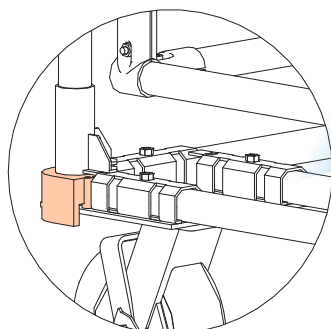
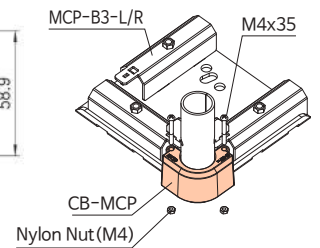
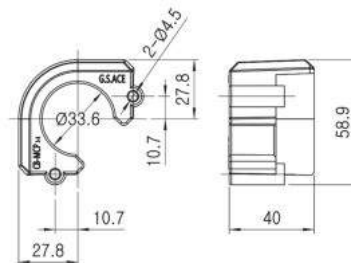

ACCESSORIES CASTER MOUNT & MOUNT CORNER UNIT

* Surface Treatment - WZ

Unit : mm

MCP-E Mount Corner Plate



Material	Steel
Weight	1.110kg
Q'ty/Box	12pcs

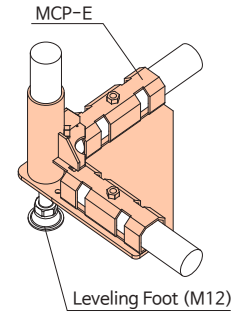
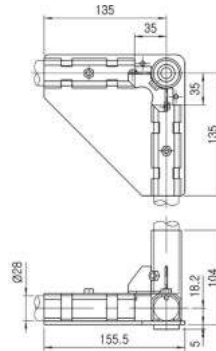

MCP-F/A/B Metal Corner Plate



Material	Steel
Weight	0.326kg
Q'ty/Box	30pcs

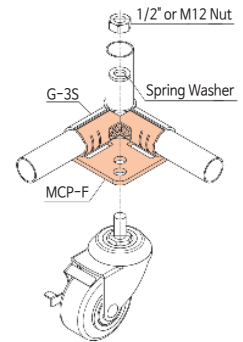
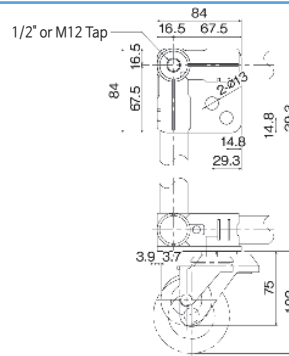

MCP-G Metal Corner Plate



Material	Steel
Weight	0.260kg
Q'ty/Box	40pcs

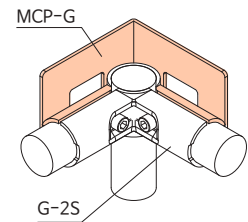
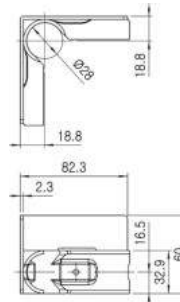

Applications of MCP-G

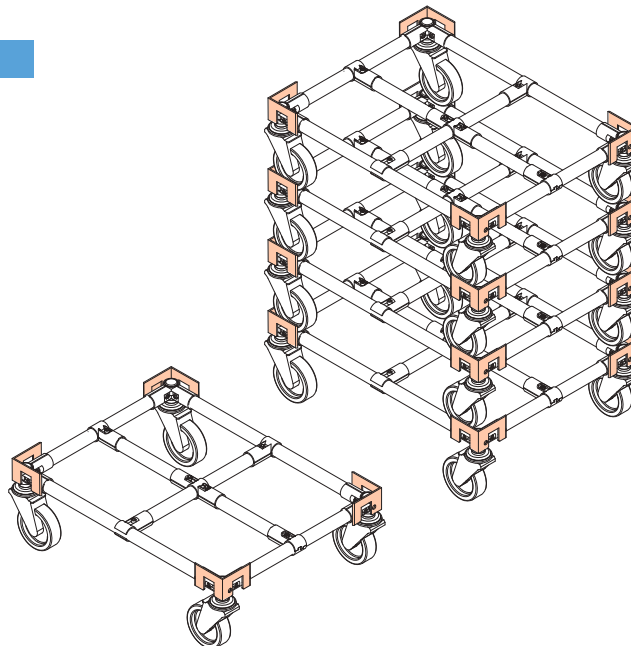

* Surface Treatment - WZ

Unit : mm

MCP-HN-L Mount Corner Plate-Left



Material	Steel
Weight	1.55kg
Q'ty/Box	12pcs

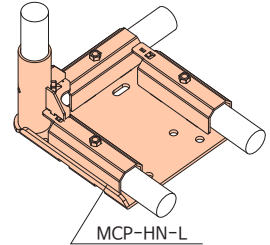
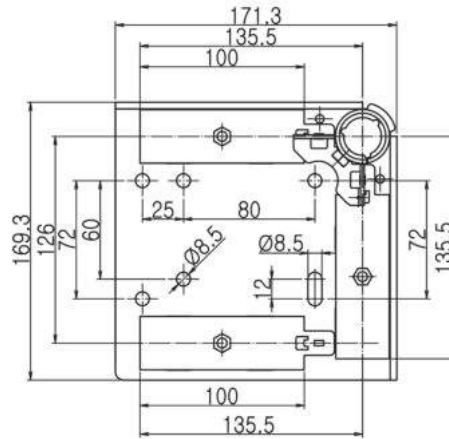

MCP-HN-R Mount Corner Plate-Right



Material	Steel
Weight	1.55kg
Q'ty/Box	12pcs

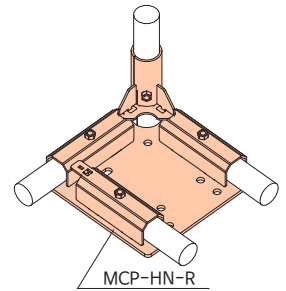
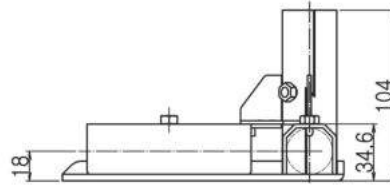

MCP-KN Mount Center Plate



Material	Steel
Weight	1.30kg
Q'ty/Box	12pcs

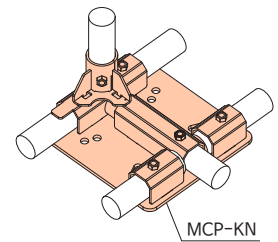
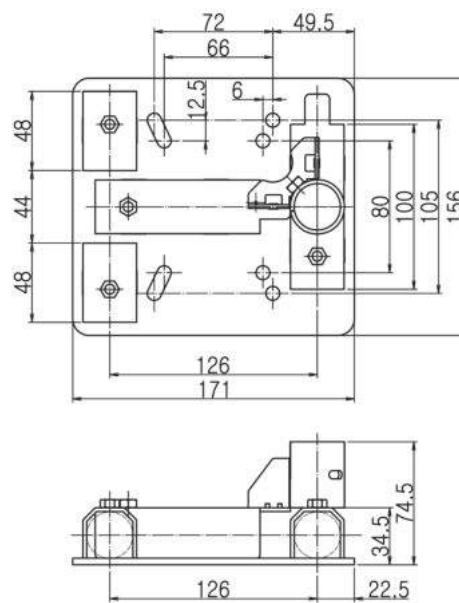

ACCESSORIES CASTER MOUNT & MOUNT CORNER UNIT

* Surface Treatment - WZ

Unit : mm

BC45-A Base Corner

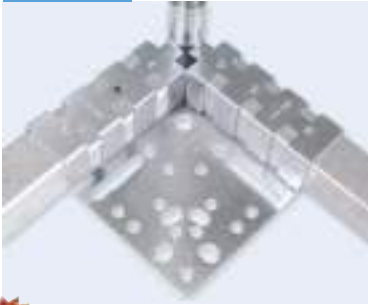

Material	Steel
Weight	1.85kg
Q'ty/Box	8pcs

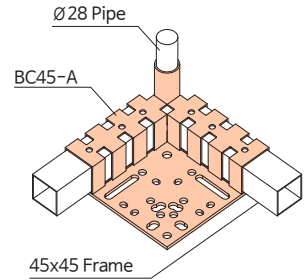
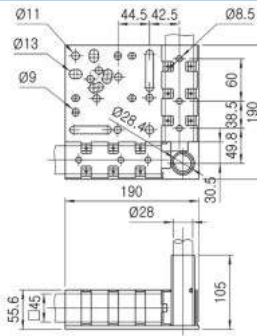

BC45-A2 Base Corner



Material	Steel
Weight	2.135kg
Q'ty/Box	8pcs

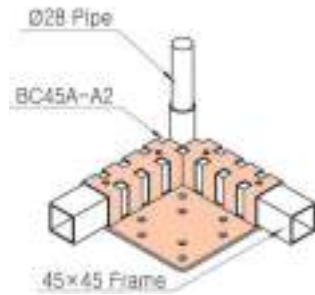
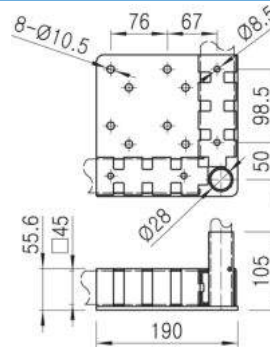

BC45-B Base Corner



Material	Steel
Weight	1.170kg
Q'ty/Box	16pcs

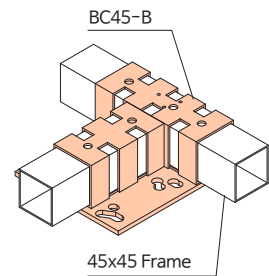
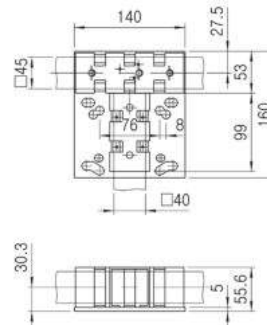

BC45-C Base Corner



Material	Steel
Weight	1.280kg
Q'ty/Box	4pcs

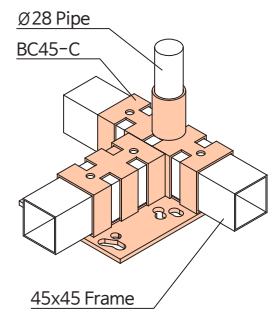
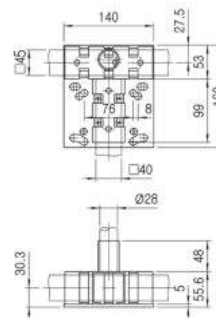

Applications of Base Corner

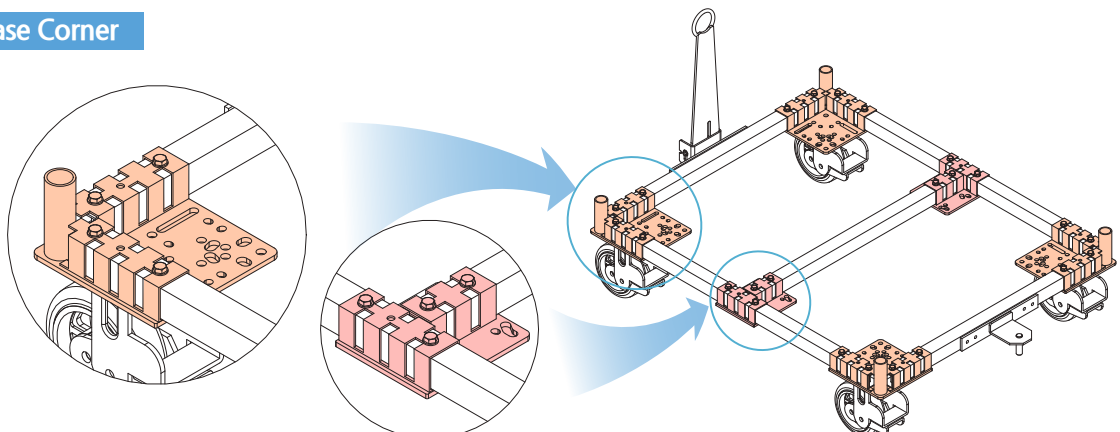

* Surface Treatment - WZ

Unit : mm

CS28L Corner Support

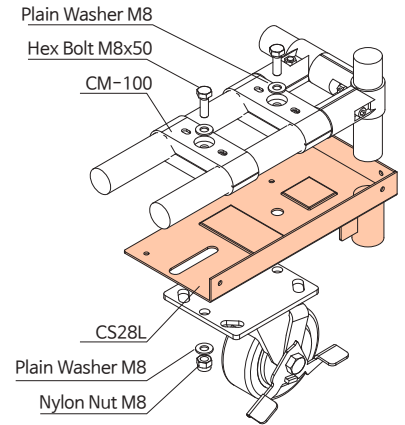
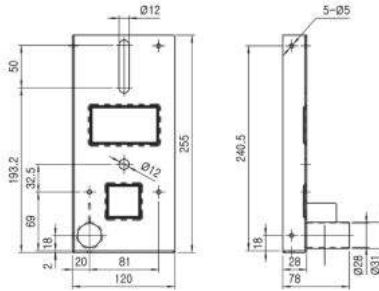

Material	Steel
Weight	0.705kg
Q'ty/Box	24pcs

CS28R Corner Support

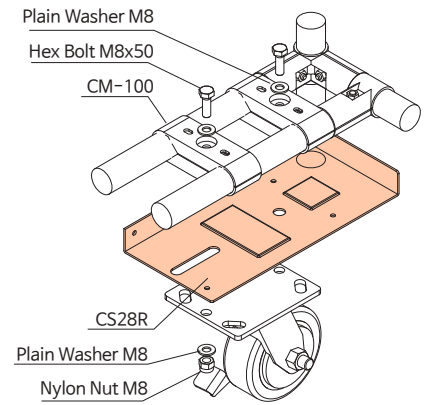
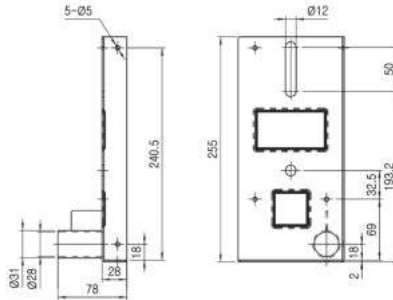

Material	Steel
Weight	0.750kg
Q'ty/Box	24pcs

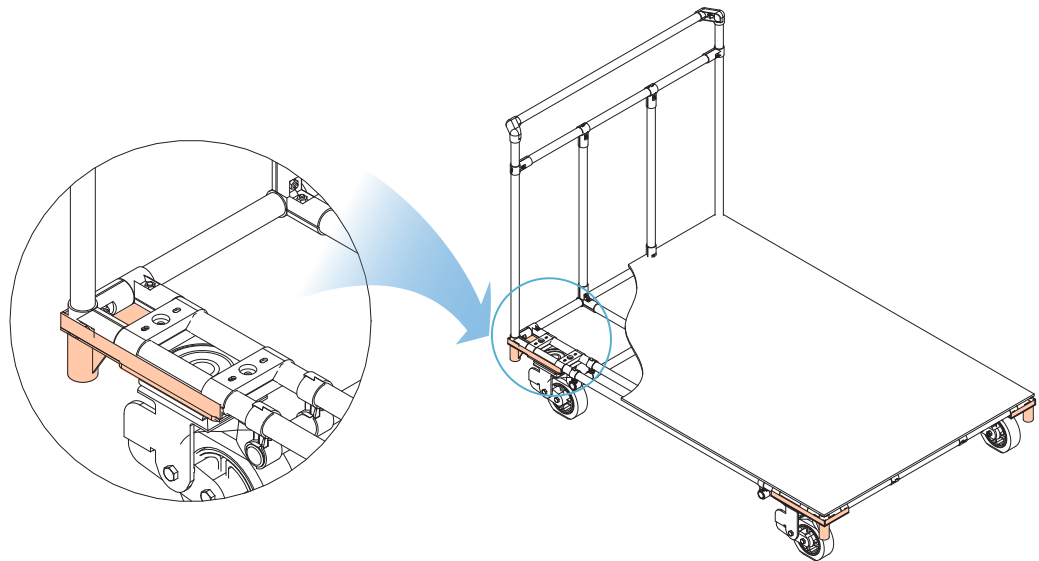

ACCESSORIES CASTER MOUNT & MOUNT CORNER UNIT

* Surface Treatment - WZ

Unit : mm

CM-A Corner Metal



Material	Steel
Weight	0.100kg
Q'ty/Box	60pcs

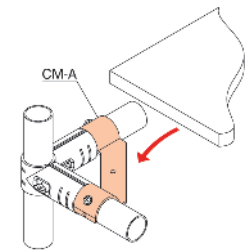
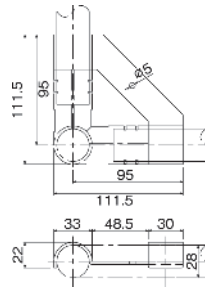

CM-B Corner Metal



Material	Steel
Weight	0.071kg
Q'ty/Box	60pcs

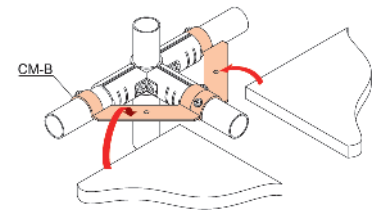
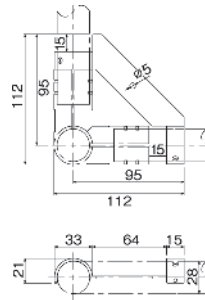

ACCESSORIES FORK GUIDE & ASS'Y HAUL

* Surface Treatment - WZ

Unit : mm

FG-01 Fork Guide



Material	Steel
Weight	2.440kg
Q'ty/Box	2pcs

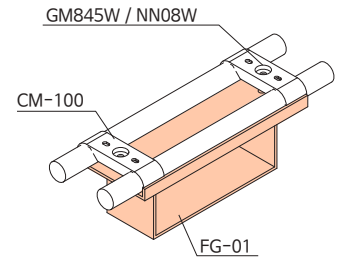
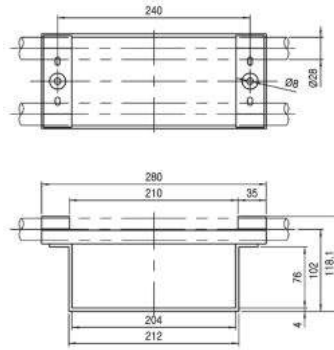

FG-03 Fork Guide



Material	Steel
Weight	1.770kg
Q'ty/Box	10pcs

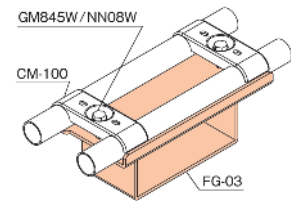
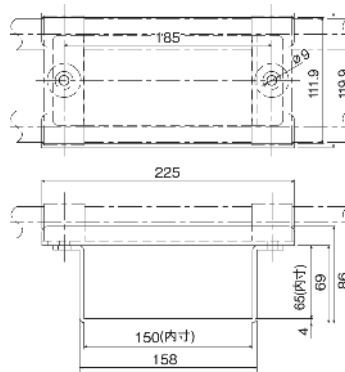

ACCESSORIES FORK GUIDE & ASS'Y HAUL

* Surface Treatment - WZ

Unit : mm

FG-04 Fork Guide



Material	Steel
Weight	2.300kg
Q'ty/Box	2pcs

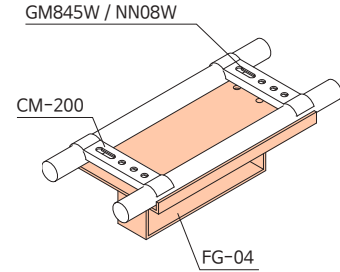
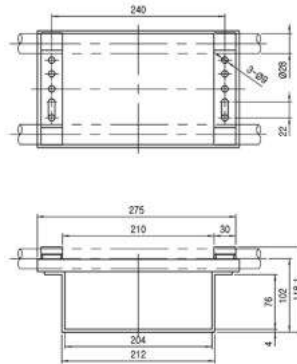

Fork Guide 적용 예

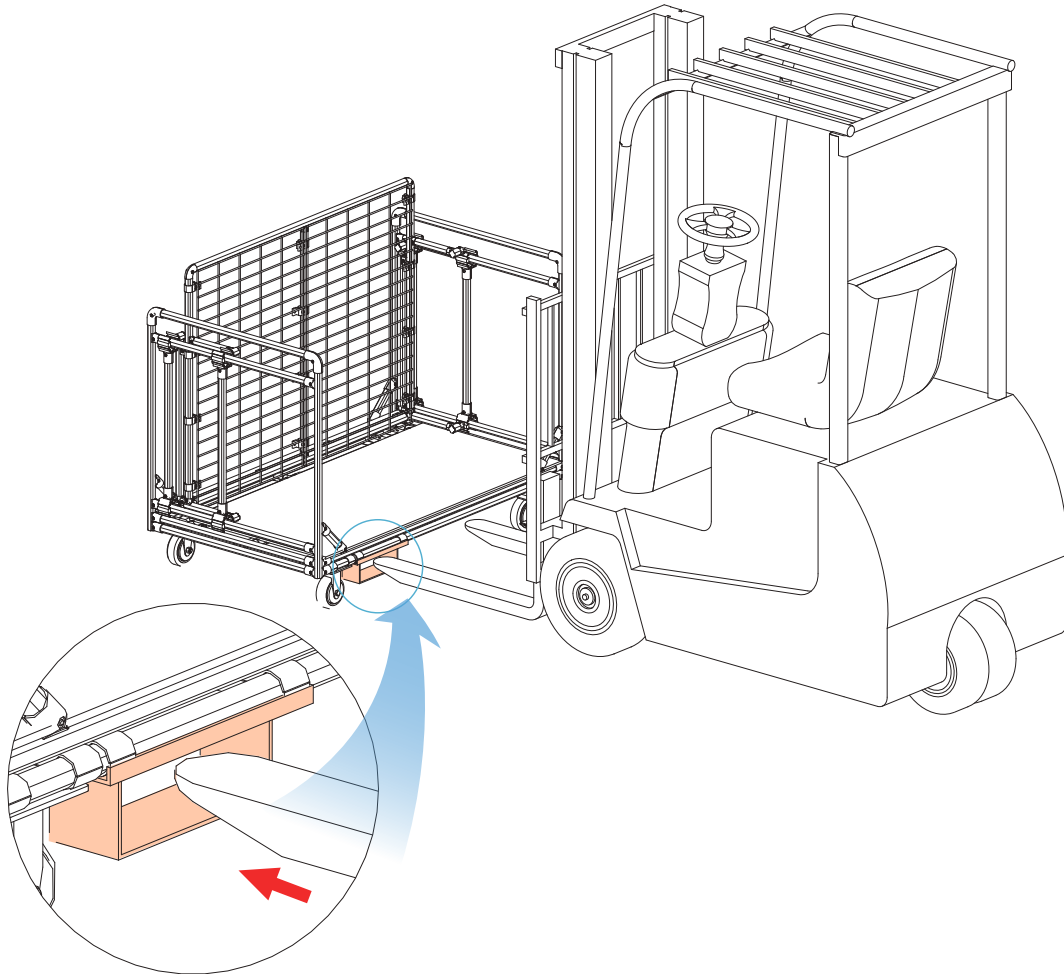

ACCESSORIES FORK GUIDE & ASS'Y HAUL

* Surface Treatment - WZ

Unit : mm

FS-A Front Haul Ass'y-Spring Type



Material	Steel
Weight	3.400kg
Q'ty/Box	4pcs

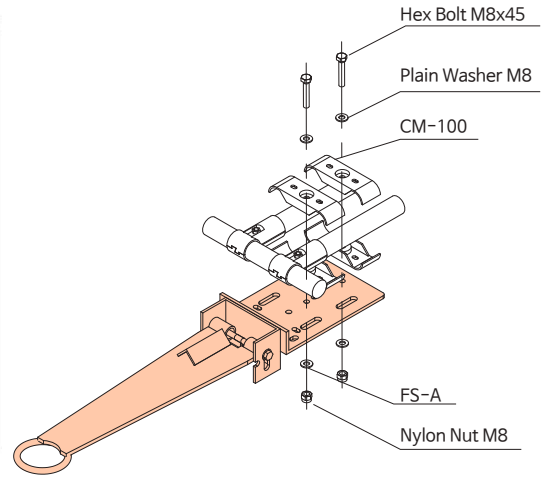
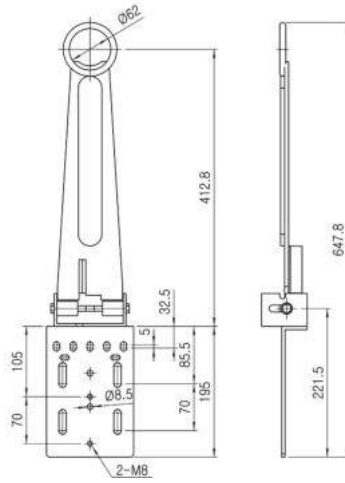

RS-A Rear Haul Ass'y-Spring Type



Material	Steel
Weight	1.500kg
Q'ty/Box	4 pcs

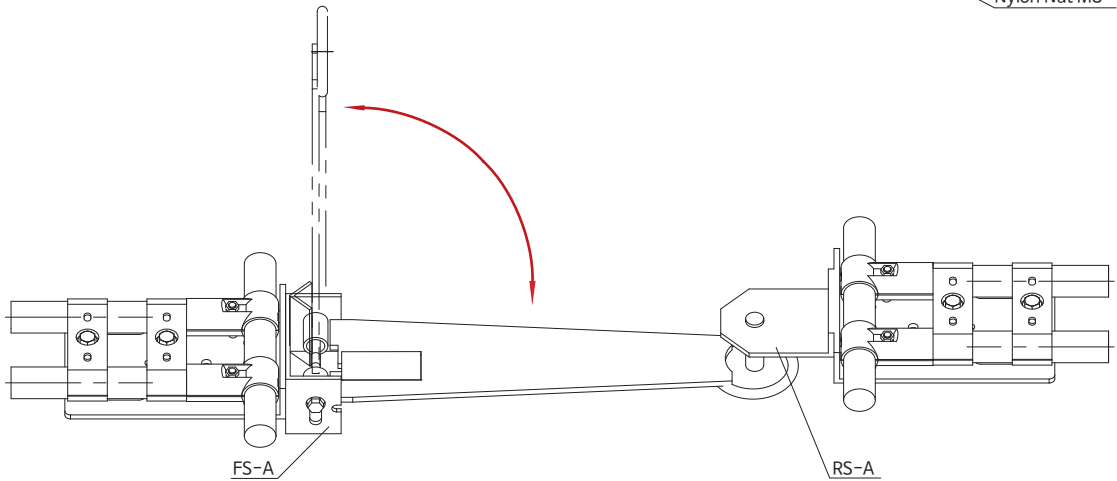
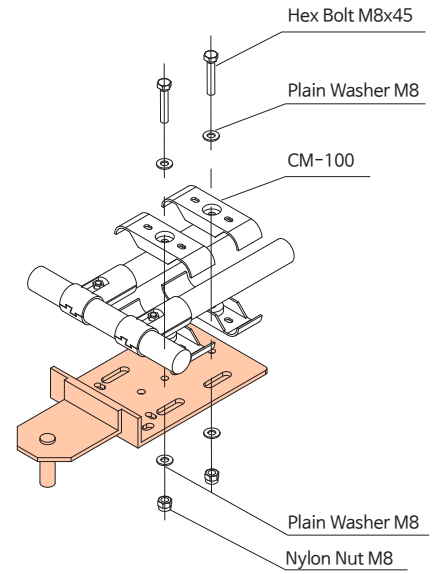
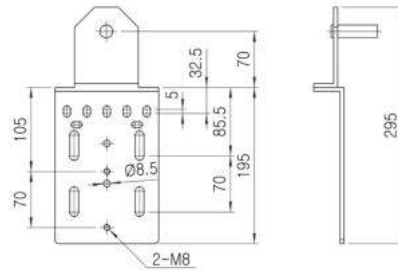

ACCESSORIES FORK GUIDE & ASS'Y HAUL

* Surface Treatment - WZ

Unit : mm

FQ-B Front Haul Ass'y-Quicking Type



Material	Steel
Weight	3.100kg
Q'ty/Box	4pcs

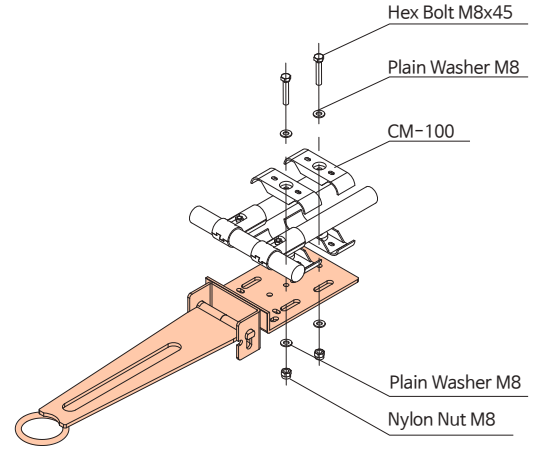
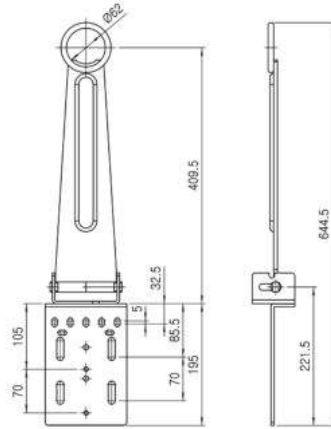

FQ-BL-1 Front Haul Ass'y



Material	Steel
Weight	2.143kg
Q'ty/Box	4pcs

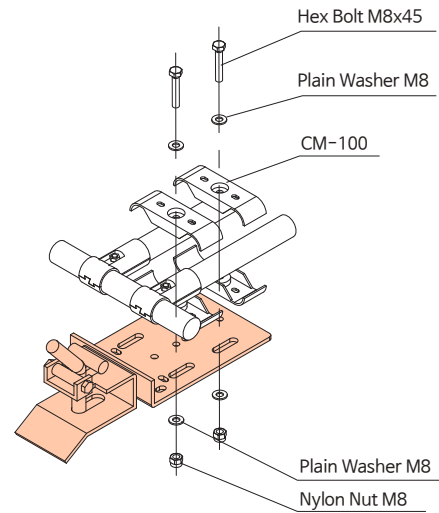
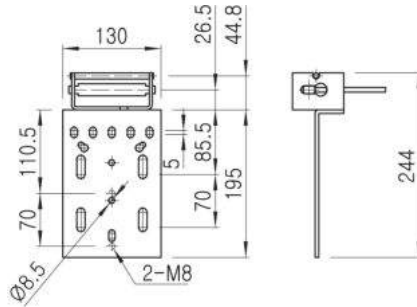

RQ-B Rear Haul Ass'y-Quicking Type



Material	Steel
Weight	2.100kg
Q'ty/Box	4pcs

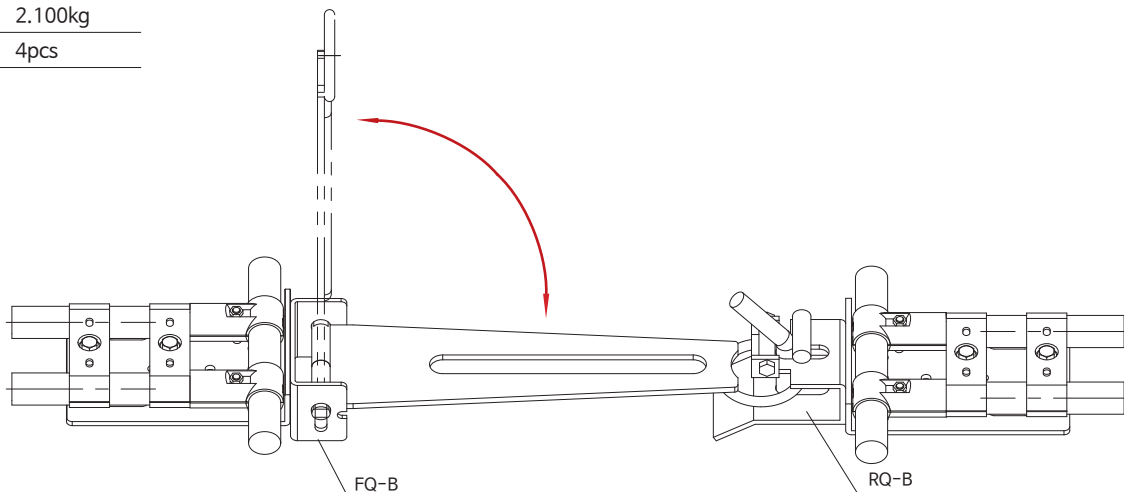
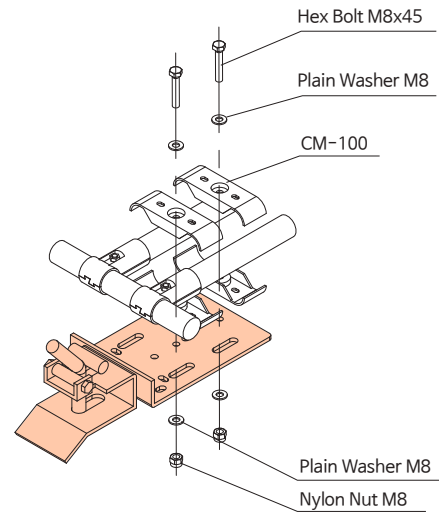
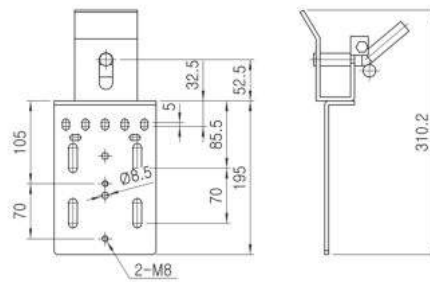

ACCESSORIES FORK GUIDE & ASS'Y HAUL

* Surface Treatment - WZ

Unit : mm

RQ-C Rear Haul Ass'y-Quicking Type



Material	Steel
Weight	3.380kg
Q'ty/Box	6pcs

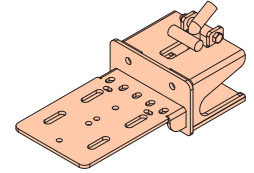
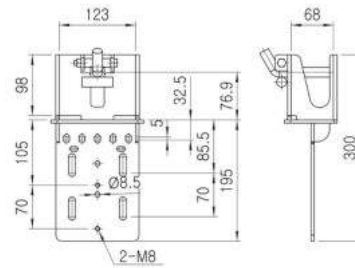

FS-AN-1 Front Haul Ring Ass'y



Material	Steel
Weight	2.046kg
Q'ty/Box	6pcs

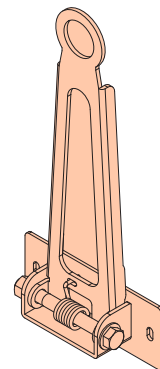
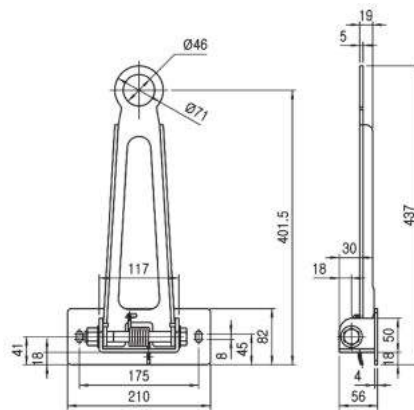

RS-AN-1 Rear Haul Ring Ass'y



Material	Steel
Weight	1.090kg
Q'ty/Box	24pcs

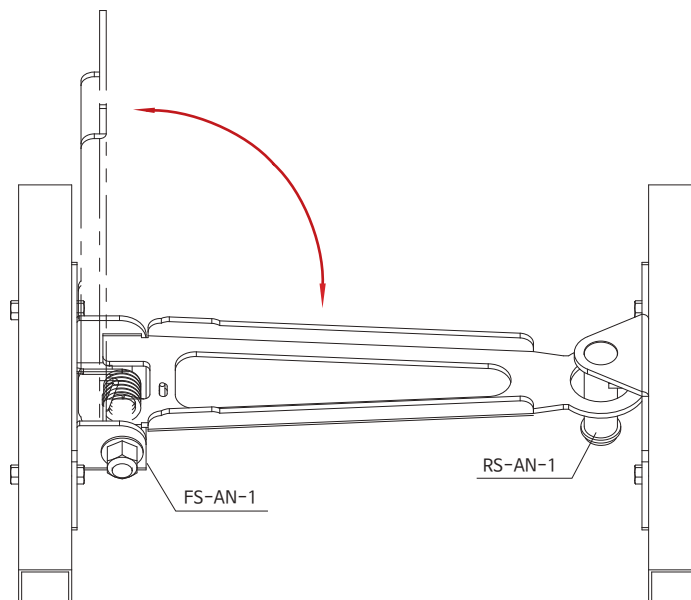
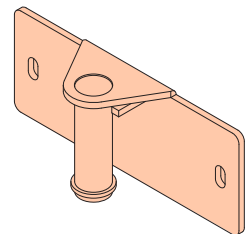
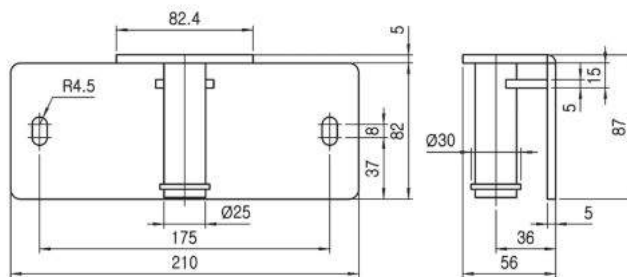

ACCESSORIES METAL CLAMP

* Surface Treatment - WZ

Unit : mm

PC-A Base Lock Metal



Material	Steel
Weight	0.063kg
Q'ty/Box	150pcs

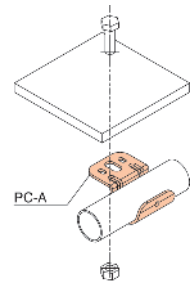
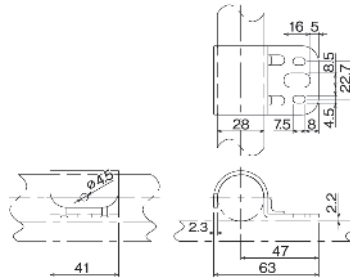

PC-BN Pipe Clamp (Single Mount)



Material	Steel
Weight	0.020kg
Q'ty/Box	300pcs

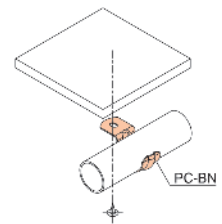
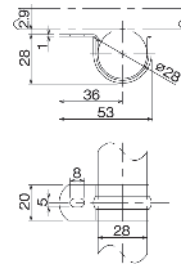

PC-CN Pipe Clamp (Double Mount)



Material	Steel
Weight	0.026kg
Q'ty/Box	400pcs

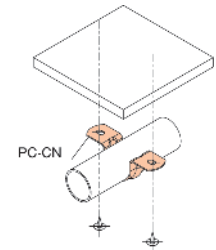
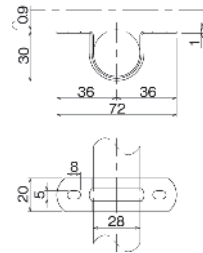

Applications of PC-A

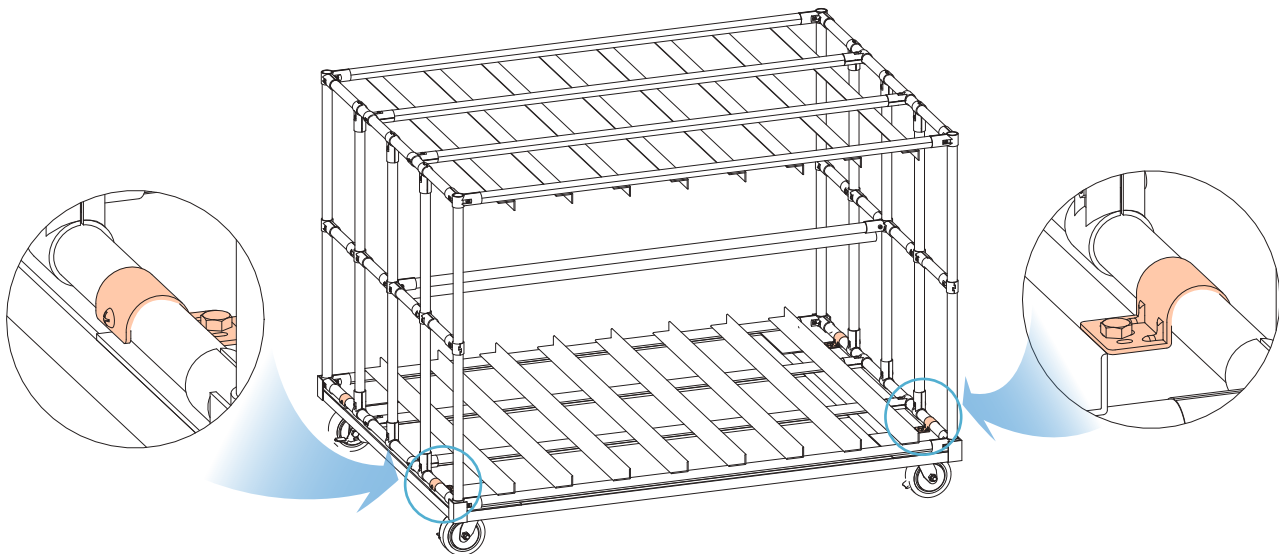

ACCESSORIES METAL CLAMP

* Surface Treatment - WZ

Unit : mm

PC-D Pipe Lock Metal



Material	Steel
Weight	0.157kg
Q'ty/Box	50pcs

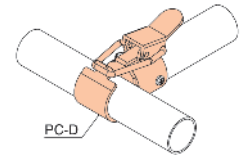
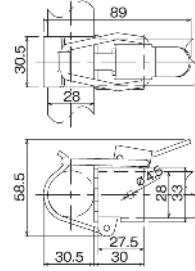

PC-E Pipe Clamp



Material	Steel
Weight	0.012kg
Q'ty/Box	400pcs

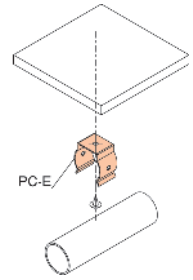
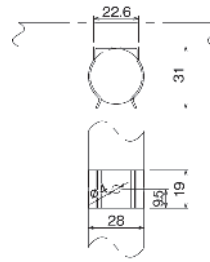

BL28YA-U Pipe Holder



Material	Steel
Weight	0.076kg
Q'ty/Box	150pcs

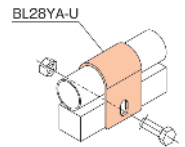
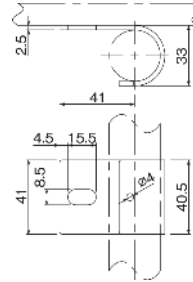

PC-D 접이식 작업대 사용 예

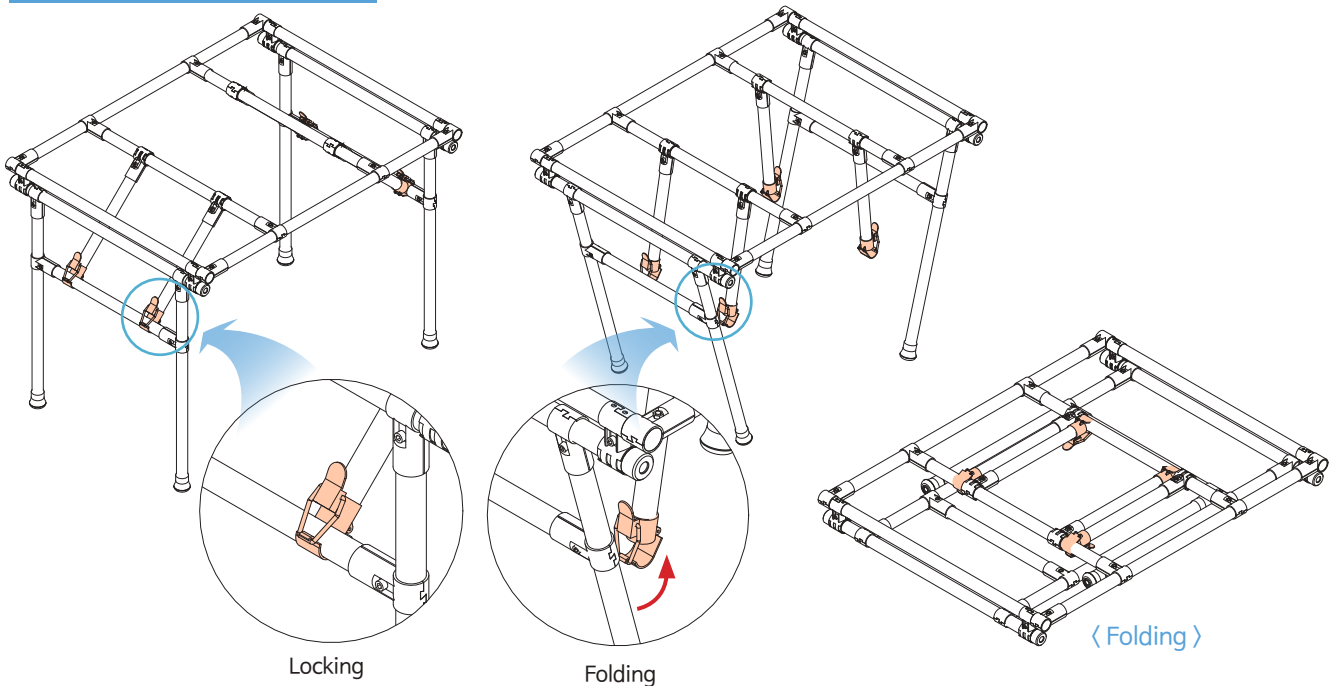

ACCESSORIES HOOK & HANGER & HANDLE

* Surface Treatment - WZ

Unit : mm

BH-A Band Hook



Material	Steel
Weight	0.001kg
Q'ty/Box	1000pcs

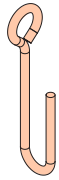
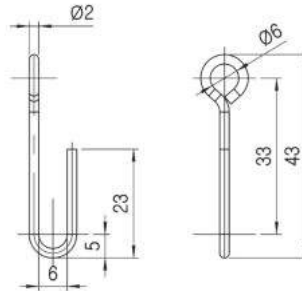

BH-B Band Hook



Material	Steel
Weight	0.001kg
Q'ty/Box	2000pcs

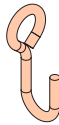
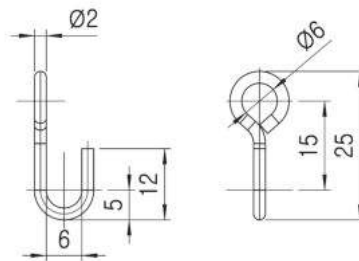

PH-A Hanger



Material	Steel
Weight	0.001kg
Q'ty/Box	500pcs

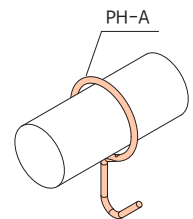
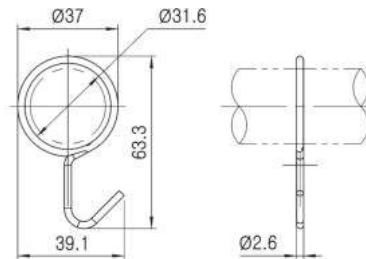

PH-B Hanger



Material	Steel
Weight	0.001kg
Q'ty/Box	250pcs

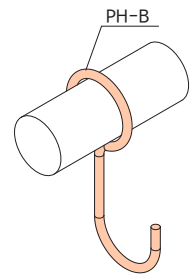
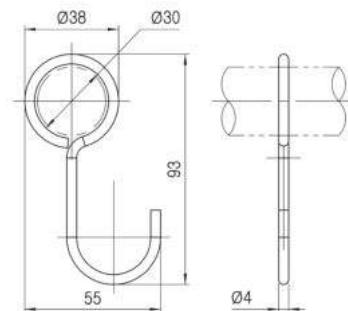

PH-B1 Hanger



Material	Steel
Weight	0.001kg
Q'ty/Box	250pcs

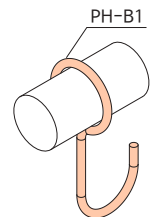
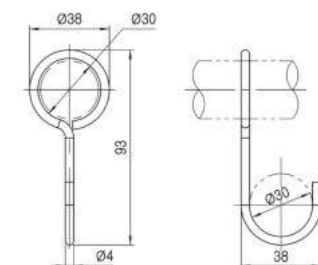

ACCESSORIES HOOK & HANGER & HANDLE

* Surface Treatment - WZ

Unit : mm

PH-C Hanger



Material	Plastic+Steel
Weight	0.019kg
Q'ty/Box	90pcs

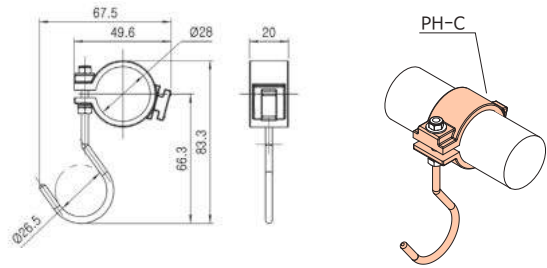

PH-D Hanger



Material	Plastic+Steel
Weight	0.017kg
Q'ty/Box	100pcs

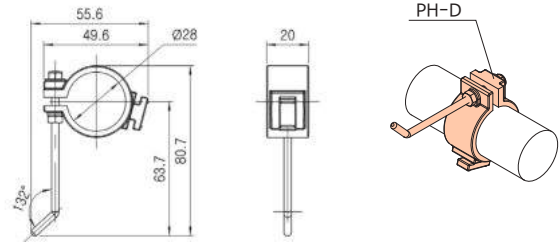

GS-1014CH Sleeve Hanger (2 Hole)



Material	Steel
Weight	0.050kg
Q'ty/Box	70pcs

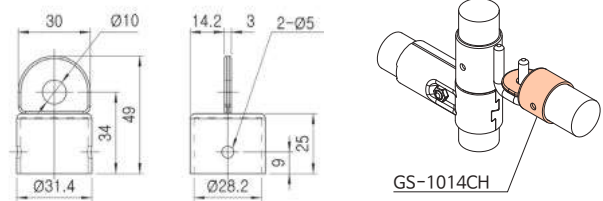

GS-1014A Sleeve Hanger



Material	Steel
Weight	0.130kg
Q'ty/Box	70 pcs

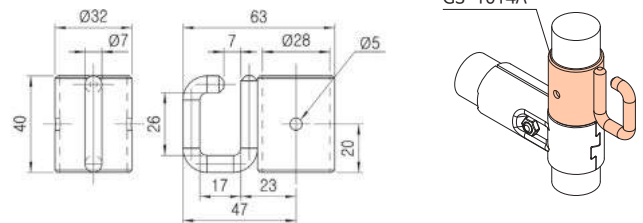

ACCESSORIES HOOK & HANGER & HANDLE

* Surface Treatment - WZ

Unit : mm

GS-1014B Sleeve Hanger



Material	Steel
Weight	0.130kg
Q'ty/Box	70pcs

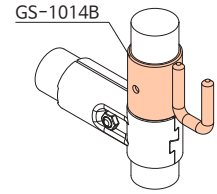
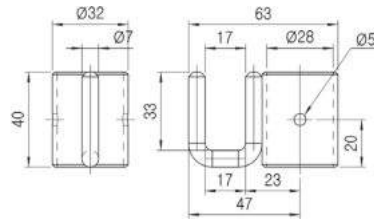

GS-1024B Sleeve Hanger



Material	Steel
Weight	0.100kg
Q'ty/Box	56pcs

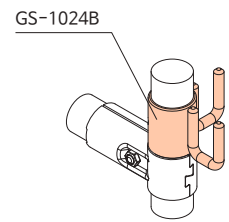
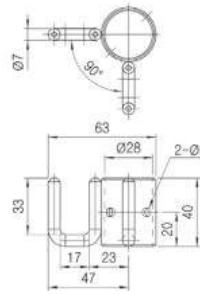

GS-1044B Sleeve Hanger



Material	Steel
Weight	0.155kg
Q'ty/Box	33pcs

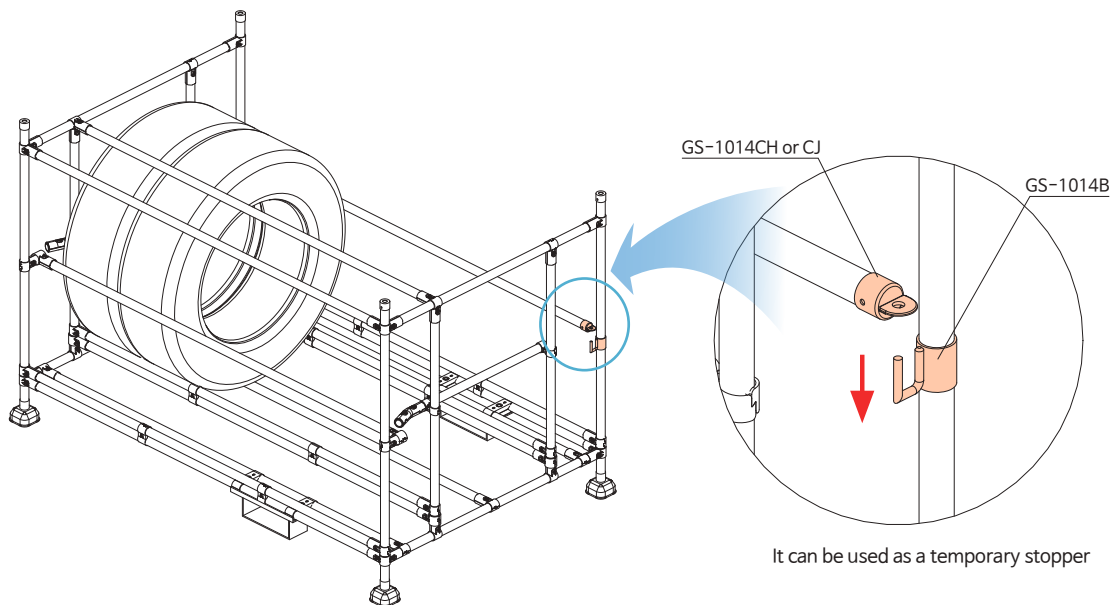
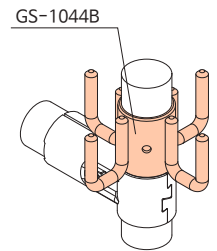
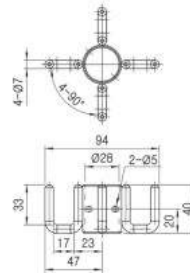

ACCESSORIES HOOK & HANGER & HANDLE

* Surface Treatment - WZ

Unit : mm

ECH-28A End Cap Hanger



Material	Steel
Weight	0.060kg
Q'ty/Box	70pcs

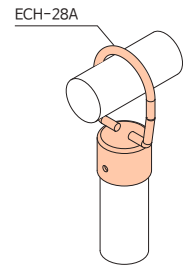
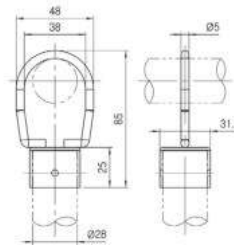

HM28YA Hanger Metal



Material	Steel
Weight	0.049kg
Q'ty/Box	100pcs

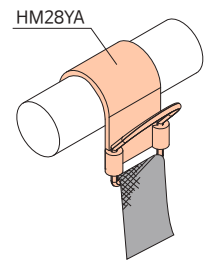
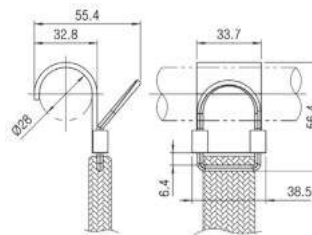

HM28YB Hanger Metal



Material	Steel
Weight	0.040kg
Q'ty/Box	100pcs

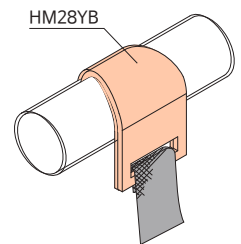
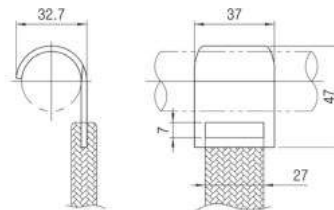

F-A Handle (Flat Type)



Material	Steel
Weight	0.020kg
Q'ty/Box	500pcs

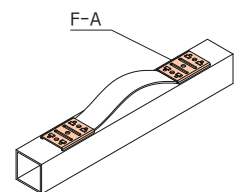
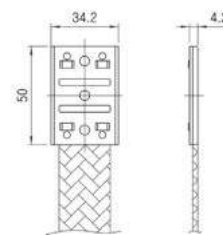

R-A Handle (Round Type)



Material	Steel
Weight	0.020kg
Q'ty/Box	400pcs

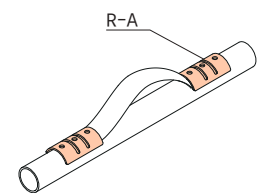
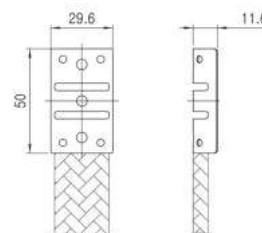

ACCESSORIES METAL JOINT COVER

* Surface Treatment - WZ

Unit : mm

MJC-G1 Metal Joint Cover

Patent Pending



Material	Plastic
Weight	0.013kg
Q'ty/Box	150pcs

* Color : Natural

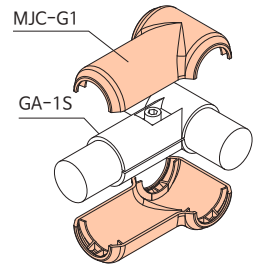
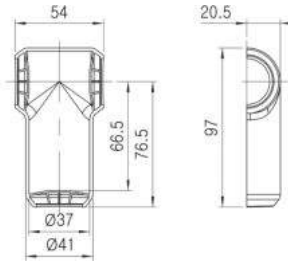

MJC-G2 Metal Joint Cover

Patent Pending



Material	Plastic
Weight	0.012kg
Q'ty/Box	280pcs

* Color : Natural

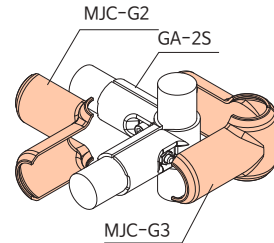
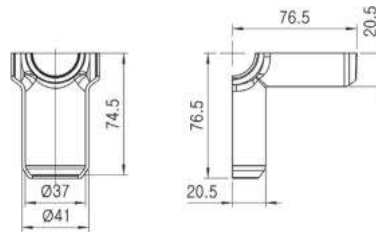

MJC-G3 Metal Joint Cover

Patent Pending

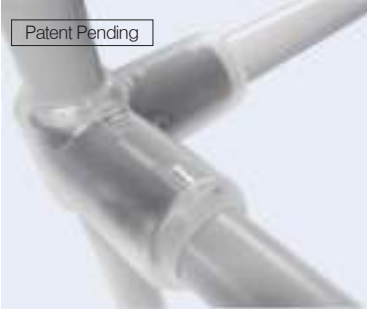

Material	Steel
Weight	0.020kg
Q'ty/Box	120pcs

* Color : Natural

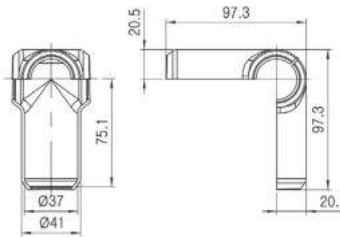

MJC-G4 Metal Joint Cover

Patent Pending



Material	Plastic
Weight	0.020kg
Q'ty/Box	120pcs

* Color : Natural

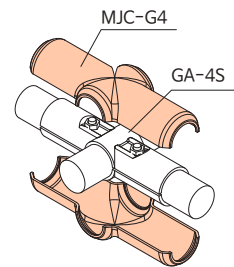
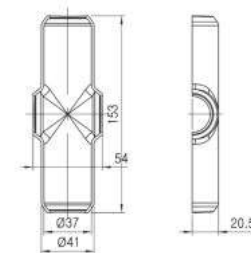

MJC-G6S Metal Joint Cover

Patent Pending

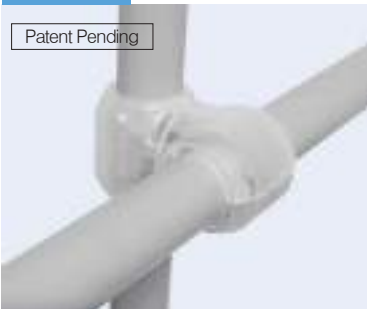

Material	Plastic
Weight	0.010kg
Q'ty/Box	150pcs

* Color : Natural

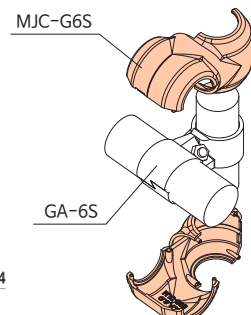
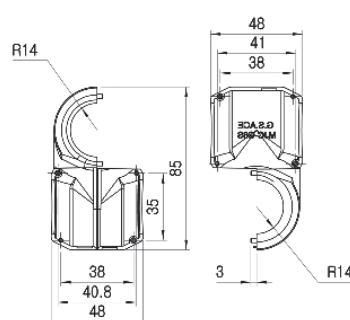

ACCESSORIES METAL JOINT COVER

* Surface Treatment - WZ

Unit : mm

MJC-G7A Metal Joint Cover

Patent Pending



Material	Plastic
Weight	0.008kg
Q'ty/Box	300pcs

* Color : Natural

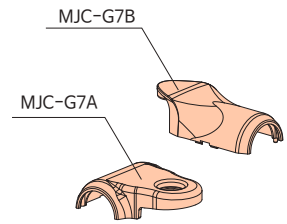
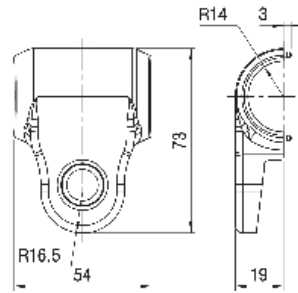

MJC-G7B Metal Joint Cover

Patent Pending



Material	Plastic
Weight	0.008kg
Q'ty/Box	300pcs

* Color : Natural

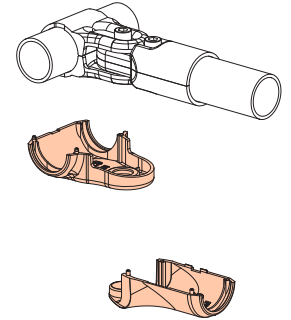
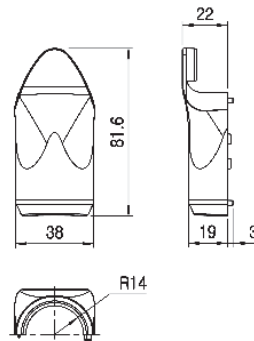

ACCESSORIES TOOL HOLDER

* Surface Treatment - WZ

Unit : mm

TH40PA Tool Holder



Material	Plastic
Weight	0.087kg
Q'ty/Box	50pcs

*TH40PA : PP (Color : BK)
*TH40PNA : Nylon6 (Color : Dark Gray)

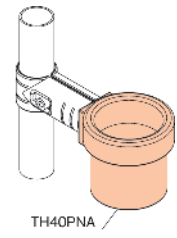
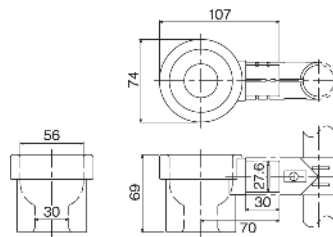

TH50PA Tool Holder



Material	Plastic
Weight	0.087kg
Q'ty/Box	50pcs

*TH50PA : PP (Color : BK)
*TH50PNA : Nylon6 (Color : Dark Gray)

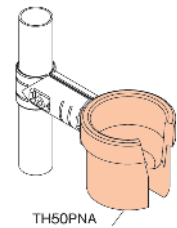
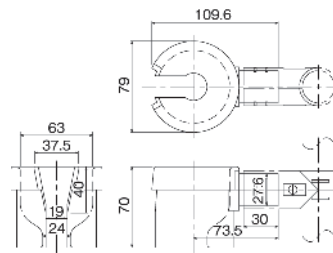

TH50YA Tool Holder



Material	Steel
Weight	0.108kg
Q'ty/Box	25pcs

* Color : WZ

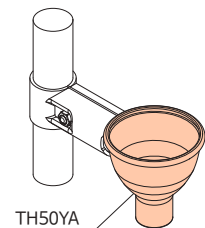
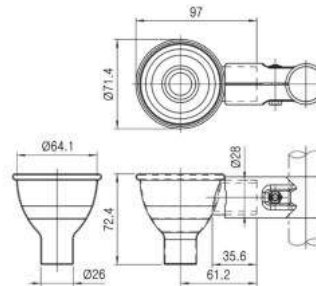

TH60PA/B Tool Holder



Material	Plastic
Weight	0.082kg
Q'ty/Box	50pcs

*TH60PA/B : PP (Color : BK)
*TH60PNA/B : Nylon6 (Color : Dark Gray)

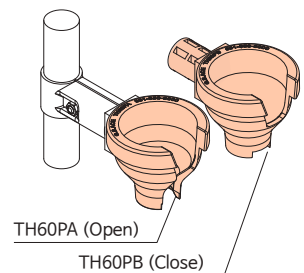
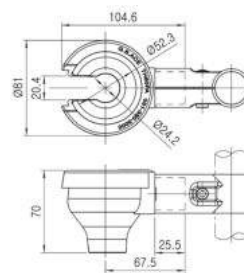

TH65YA Tool Holder

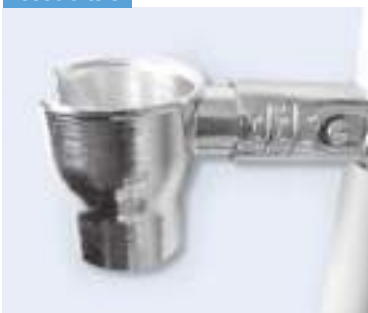

Material	Steel
Weight	0.197kg
Q'ty/Box	25pcs

* Color : WZ

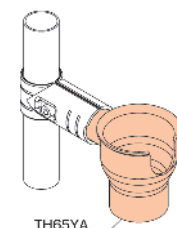
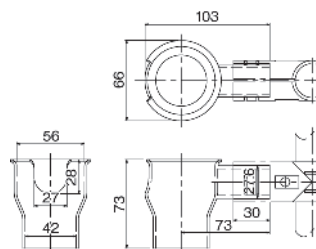

ACCESSORIES ASS'Y PULLEY

* Surface Treatment - WZ

Unit : mm

GRHA-15R Bearing Pulley Ass'y (Right)



Material	Steel
Weight	0.129kg
Q'ty/Box	-

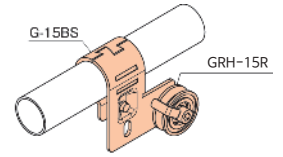
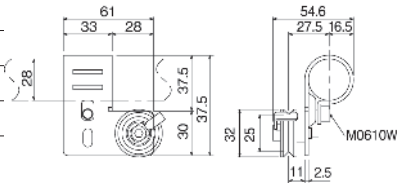

GRH-15R Pulley Holder BKT (Right)



Material	Steel
Weight	0.055kg
Q'ty/Box	270pcs

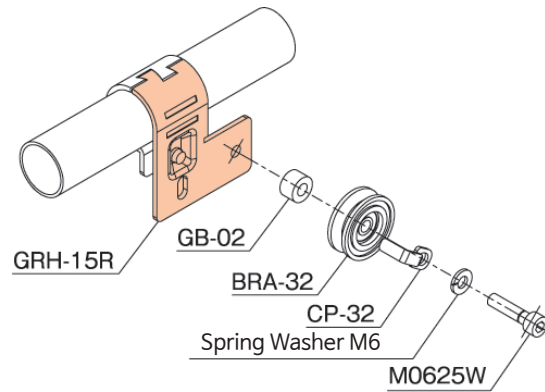

GRHA-15L Bearing Pulley Ass'y (Left)



Material	Steel
Weight	0.129kg
Q'ty/Box	-

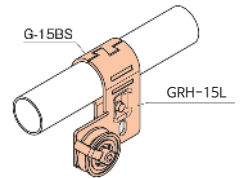
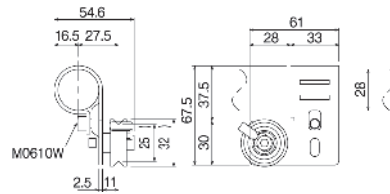

GRH-15L Pulley Holder BKT (Left)



Material	Steel
Weight	0.055kg
Q'ty/Box	270pcs

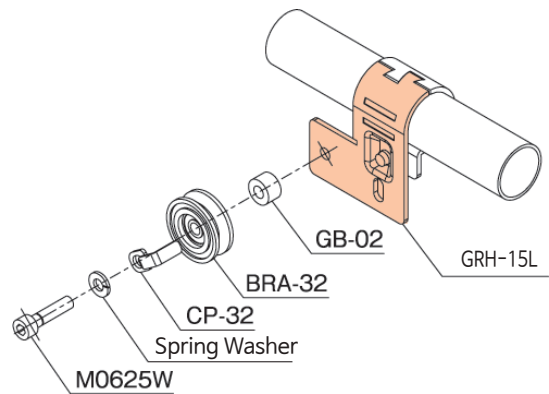

ACCESSORIES ASS'Y PULLEY

* Surface Treatment - WZ

Unit : mm

GRVA-15R Bearing Pulley Ass'y (Right)



Material	Steel
Weight	0.122kg
Q'ty/Box	-

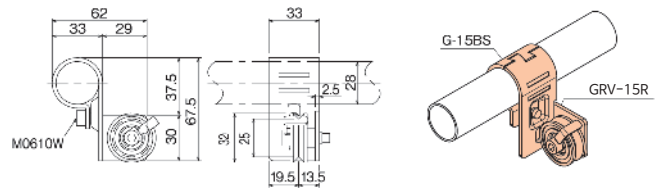

GRV-15R Pulley Holder BKT (Right)



Material	Steel
Weight	0.055kg
Q'ty/Box	240pcs

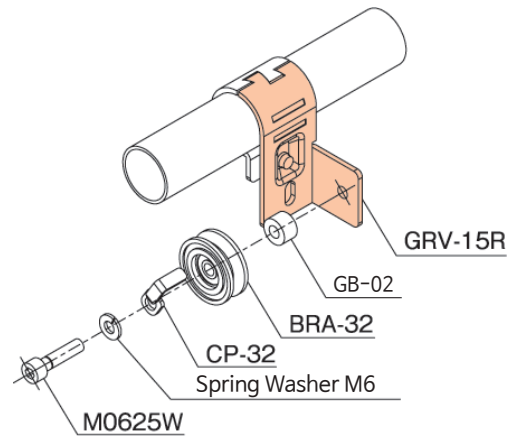

GRVA-15L Bearing Pulley Ass'y (Left)



Material	Steel
Weight	0.122kg
Q'ty/Box	-

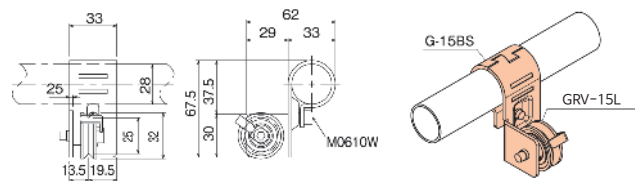

GRV-15L Pulley Holder BKT (Left)



Material	Steel
Weight	0.055kg
Q'ty/Box	240pcs

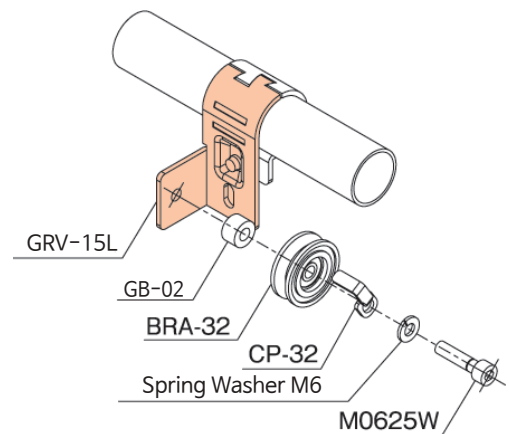

ACCESSORIES ASS'Y PULLEY

* Surface Treatment - WZ

Unit : mm

BRA-32 Bearing Pulley



Material	Steel
Weight	0.012kg
Q'ty/Box	1,000pcs

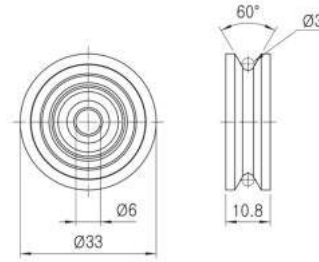

GB-02 Gap Bushing



Material	Steel
Weight	0.0061kg
Q'ty/Box	2,000pcs

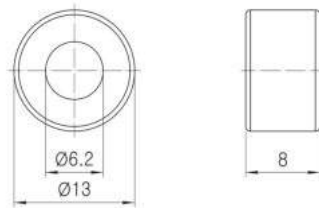

CP-32 Wire Holder (Wire falling preventer)



Material	Steel
Weight	0.004kg
Q'ty/Box	3,000pcs

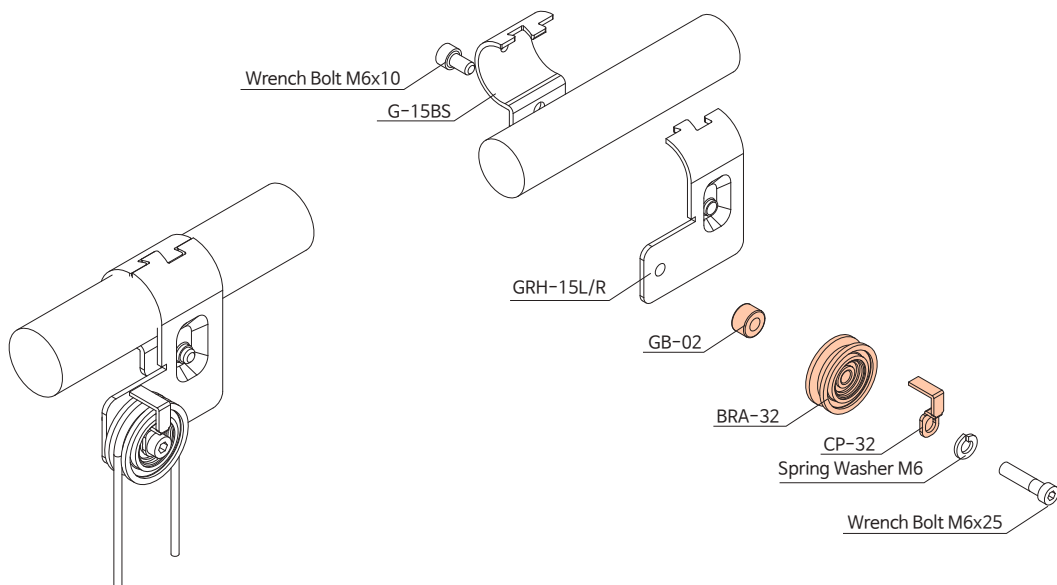
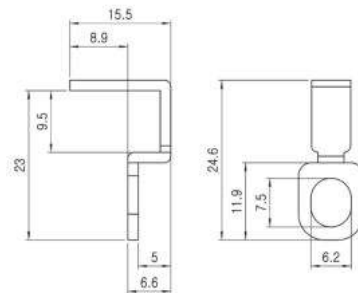

ACCESSORIES NAME PLATE & LABEL CASE

Unit : mm

NP-A Name Plate



Material	PVC
Weight	0.080kg
Q'ty/Box	180pcs

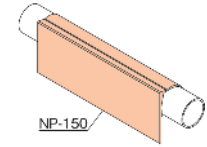
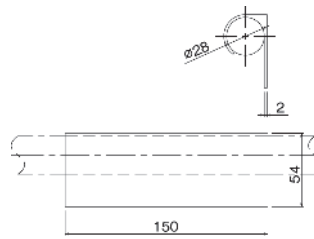

NP-B Name Plate



Material	PVC
Weight	0.047kg
Q'ty/Box	360pcs

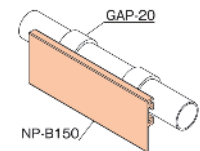
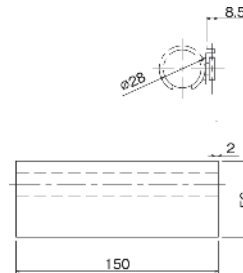

NP-C Name Plate



Material	PVC
Weight	0.035kg
Q'ty/Box	190pcs

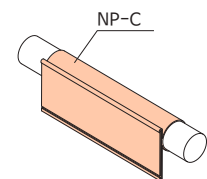
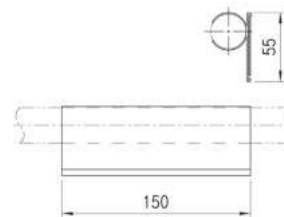

NP-D Name Plate



Material	PVC
Weight	0.032kg
Q'ty/Box	190pcs

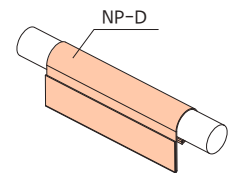
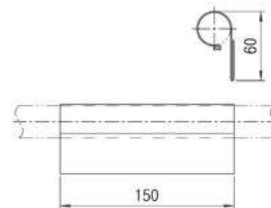

NP-E Name Plate



Material	PVC
Weight	0.023kg
Q'ty/Box	330pcs

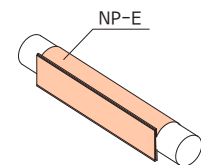
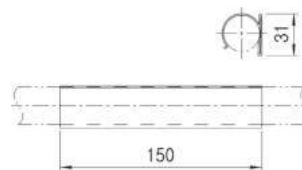

ACCESSORIES NAME PLATE & LABEL CASE

Unit : mm

NP-F Name Plate (Requires GAP-58, sold separately)



Material	PVC
Weight	0.017kg
Q'ty/Box	1000pcs

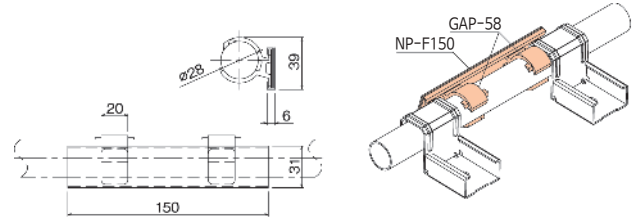

NP-F40 Name Plate (Requires GAP-58, sold separately)



Material	PVC
Weight	0.019kg
Q'ty/Box	1000pcs

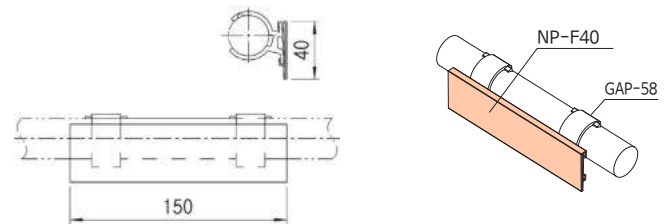

NP-G Name Plate (Requires GAP-58, sold separately)



Material	PVC
Weight	0.026kg
Q'ty/Box	360pcs

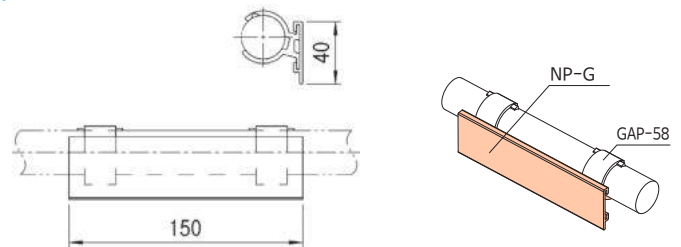

NP-H Name Plate (Double-sided adhesive tape type)



Material	PVC
Weight	0.013kg
Q'ty/Box	1000pcs

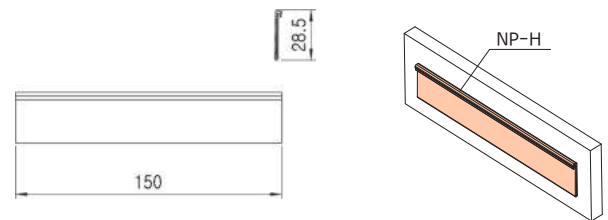

NP-R Name Plate



Material	PVC
Weight	0.011kg
Q'ty/Box	1000pcs

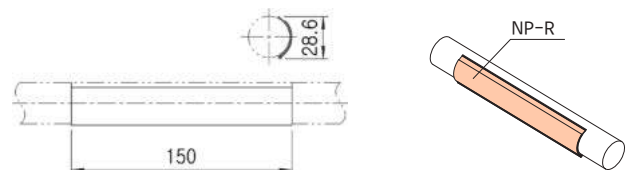

ACCESSORIES NAME PLATE & LABEL CASE

Unit : mm

NP-K Name Plate



Material	PVC
Weight	0.013kg
Q'ty/Box	300pcs

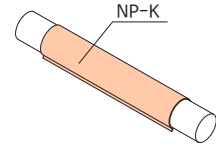
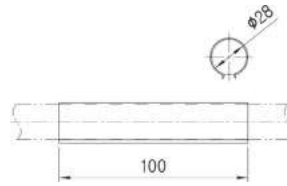

NP-L Name Plate (Double-sided adhesive tape type)



Material	PVC
Weight	0.020kg
Q'ty/Box	1000pcs

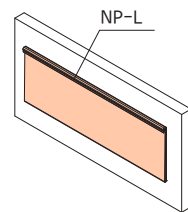
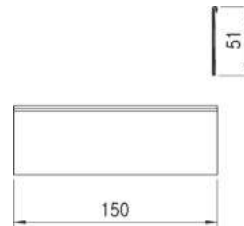

NP-M Name Plate



Material	PVC
Weight	0.016kg
Q'ty/Box	1000pcs

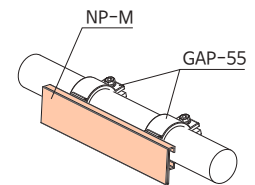
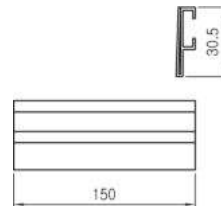

LABEL CASE

Unit : mm

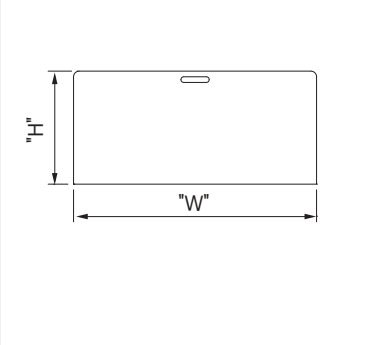
Configuration		Hole	Part No	W	H	Weight (kg)	Q'ty/Box (pcs)
		4 Hole	LA 300*100	300	100	0.040	150
			LA-B 300*120	300	120	0.045	150
			LA-C 300*220 (Horizontal)	300	220	0.084	200
			LA-A3 430*320	430	320	0.177	100
			LC 250*80	250	80	0.024	250
			LC 250*100	250	100	0.030	300
		3 Hole	LC-B 210*80	210	80	0.021	300
			LA-D3 150*60	150	60	0.012	1500
			LA-G 230*95	230	95	0.027	1250
			LA-E 210*100	210	100	0.028	250
		2 Hole	LA2 300*100	300	100	0.040	150
			LA 215*160	215	160	0.045	200
			LA-C2 220*300 (Vertical)	220	300	0.080	200
		1 Hole	LA-D 150*60	150	60	0.012	1500
			LA-H 170*135	170	135	0.030	300
			LA-P 136*40	136	40	0.007	300
			LA-R 105*100	105	100	0.011	500
			LC 180*85	180	85	0.021	300

ACCESSORIES LEVELING FOOT

Small-Type

Unit : mm

AD30PA Leveling Foot



Material	Steel&Plastic
Weight	0.035kg
Q'ty/Box	150pcs

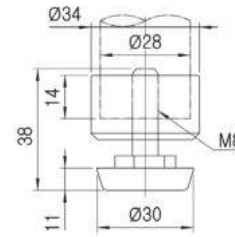

AD32WA Leveling Foot



Material	Steel&Plastic
Weight	0.053kg
Q'ty/Box	125pcs

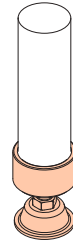
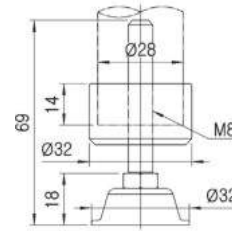

Nomal-Type

AD32WB Leveling Foot



Part No.	Material	Threaded	"L"	ESD
AD32WB	Steel (WZ)	1/2"-12N	50	○
AD32WC			100	○
AD32WD			150	○
AD32WB-M	M12-P1.75		50	○
AD32WC-M			100	○

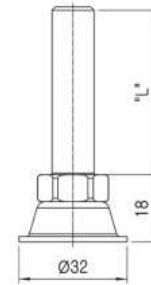

AD50WA Leveling Foot



Part No.	Material	Threaded	"L"	ESD
AD50WA	Steel (WZ)	1/2"-12N	50	○
AD50WB			100	○
AD50WD			150	○
AD50WE			200	○
AD50WA-M	M12-P1.75		50	○
AD50WB-M			100	○

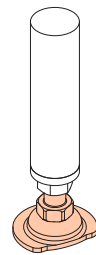
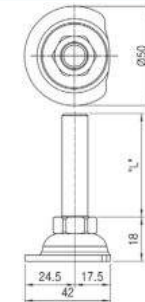

AD50WA-AC Leveling Foot



Part No.	Material	Threaded	"L"	ESD
AD50WA-AC	Steel (WZ)	1/2"-12N	50	○
AD50WB-AC			100	○
AD50WD-AC			150	○
AD50WE-AC			200	○
AD50WA-ACM	M12-P1.75		50	○
AD50WB-ACM			100	○

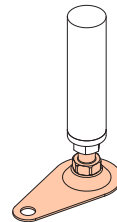
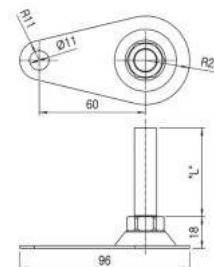

AD50RAN-H Hexgon Leveling Foot

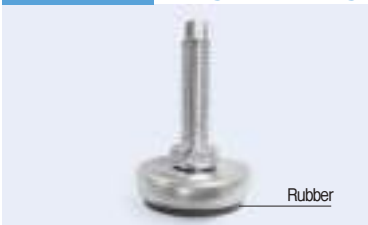

Part No.	Material	Threaded	"L"	ESD
AD50RAN-H	Steel (WZ)	1/2"-12N	50	X
AD50RAN-HM		M12-P1.75		X

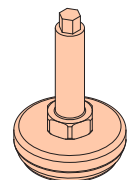
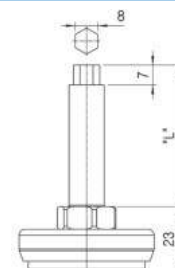

ACCESSORIES LEVELING FOOT

Unit : mm

■ STS-Type

AD35SA Leveling Foot



Part No.	Material	Threaded	"L"	ESD
AD35SA	STS	1/2"-12N	50	○
AD32SB			100	○
AD35SA-M		M12-P1.75	50	○
AD35SB-M			100	○

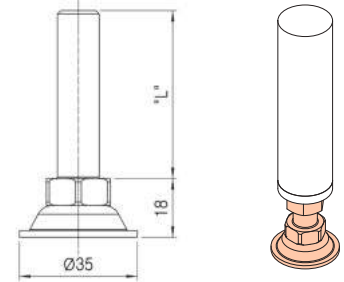

AD40SPA Rubber Leveling Foot



Part No.	Material	Threaded	"L"	ESD
AD40SPA	STS	1/2"-12N	50	X
AD40SPA-E				○
AD40SPB			100	X
AD40SPB-E				○
AD40SPA-M		M12-P1.75	50	X
AD40SPA-EM				100
AD40SPB-M			50	X
AD40SPB-EM				100

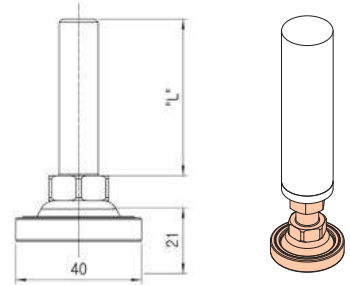

■ Rubber Pad-Type

AD32RA Rubber Pad Leveling Foot

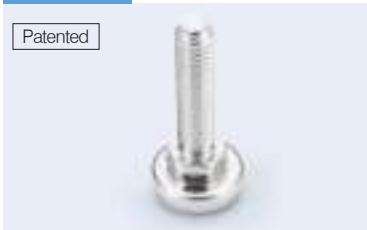

Part No.	Material	Threaded	"L"	ESD
AD32RA	Steel (WZ)	1/2"-12N	50	X
AD32RA-E				○
AD32RB			100	X
AD32RB-E				○
AD32RA-M		M12-P1.75	50	X
AD32RA-EM				○
AD32RB-M			100	X
AD32RB-EM				○

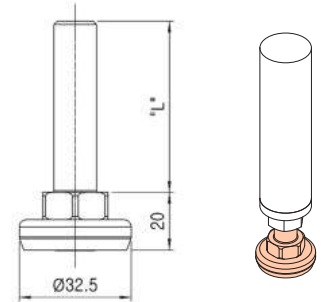

AD50RAN Rubber Pad Leveling Foot

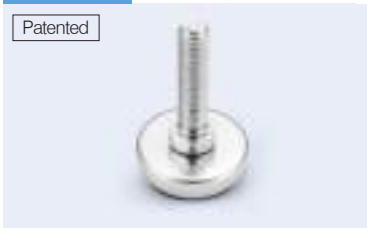

Part No.	Material	Threaded	"L"	ESD
AD50RAN	Steel (WZ)	1/2"-12N	50	X
AD50RAN-E				○
AD50RBN				100
AD50RBN-E			○	
AD50REN			200	
AD50RAN-M			M12-P1.75	50
AD50RAN-EM		○		
AD50RBN-M		100		
AD50RBN-EM				○
AD50RDN-M				150

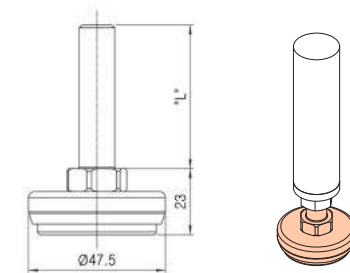

RB-AD37 Rubber Pad(For AD32W)

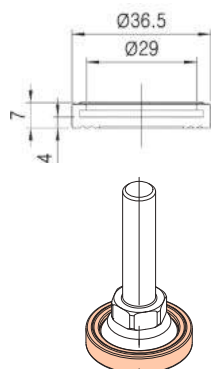
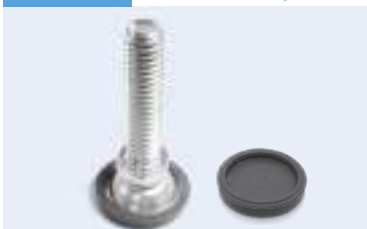

Material	Rubber
Weight	1,500pcs
Q'ty/Box	0.006kg

RB-AD45 Rubber Absorbent Pad(For AD32W)

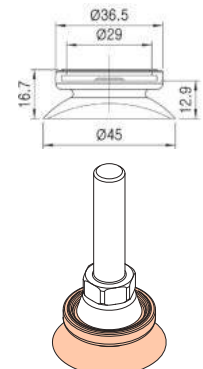





Material	Rubber
Weight	2,500pcs
Q'ty/Box	0.011kg

ACCESSORIES THREADED INSERT & CAP

Threaded Insert for Metal Rack

Unit : mm

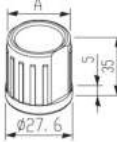
	Part No	Classification	Application	Colors	Threaded Spec	Material	A	Dimension
	BC2807A	Coated Pipe	Ø28×T0.7	White	1/2"-12N	Steel	Ø24.1	
	BC2807B				M12-P1.75			
	BC2807D			White	M10-P1.5			
	BC2809A			White	1/2"-12N	Steel		
	BC2809B		M12-P1.75					
	BC2810A		Ø28×T1.0	White	1/2"-12N	Steel	Ø23.5	
	BC2810B				M12-P1.75			
	BC2810D		White	M10-P1.5	Steel	Ø22.7		
	BC2814A						Ø28×T1.4	
	BC2814B		M12-P1.75					
	BC2820A		Ø28×T2.0	White	1/2"-12N	Steel	Ø21.9	
	BC2820B				M12-P1.75			
	BC2820D		Ø28×T2.0	White	M10-P1.5	Steel		
			BS07A	STS Pipe ECCO Pipe	Ø28×T0.7	White	1/2"-12N	
BS07B		M12-P1.75	Ø26.3					
BS07D		M10-P1.5						
BS10A		Ø28×T1.0	White		1/2"-12N	Steel	Ø26.1	
BS10B					M12-P1.75			
BS12A		Ø28×T1.2	White		1/2"-12N	Steel	Ø25.5	
BS12B					M12-P1.75		Ø25.3	
BS12D					M10-P1.5			
BC3210A	Coated Pipe	Ø32×T1.0	White	1/2"-12N	Steel	Ø27.5		
BC3210B				M12-P1.75	Steel			
	AS2807A	STS Pipe ECCO Pipe	Ø28×T0.7	Gray	1/2"-12N	Aluminum	Ø26.5	
	AS2807B				M12-P1.75			
	AC2809A		Ø28×T0.9		1/2"-12N		Ø23.8	
	AC2809B				M12-P1.75			
	AC2814A		Ø28×T1.4		1/2"-12N		Ø22.8	
	AC2814B				M12-P1.75			

Inner Cap for Metal Rack

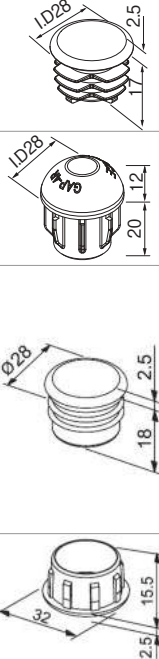
	Classification	Part No	Colors	Marking	Material	Dimension	
Ø28	All Thickness Pipe (Coated & STS Pipe & ECCO Pipe)	GAP-4P-i	Ivory	GAP-4P	Plastic		
		GAP-4P-B	Black				
		GAP-4P-G	Gray				
		GAP-4R-B	Black	GAP-4R			
		Coated Pipe	GAP-4C-i	Ivory			GAP-4C
			GAP-4C-B	Black			
	GAP-4C-G		Gray				
	STS Pipe ECCO Pipe	GAP-4S-i	Ivory	GAP-4S			
		GAP-4S-B	Black				
		GAP-4S-G	Gray				
Ø32	Coated Pipe	GAP-4310-i	Ivory	GAP-4310			
		GAP-4310-B	Black				
		GAP-4310-G	Gray				

ACCESSORIES THREADED INSERT & CAP

Unit : mm

GAS-07A Steel Cap



Part No.	Material	Pipe	Diameter	Remark
GAS-07A	Steel	Coated Pipe	Ø28 x t0.7	WZ
GAS-10A		Coated Pipe	Ø28 x t1.0	
GAS-07S		STS/ECCO Pipe	Ø28 x t0.7	
GAS-12S		STS/ECCO Pipe	Ø28 x t1.2	
Weight		0.009kg		
Q'ty/Box		600pcs		

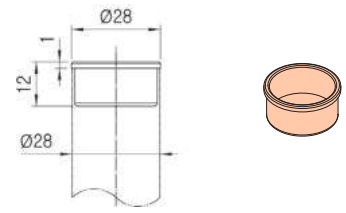

GAM-07S Metal Cap



Part No.	Material	Pipe	Diameter	Remark
GAM-07S	Steel	STS/ECCO Pipe	Ø28 x t0.7	WZ
Weight		0.037kg		
Q'ty/Box		500pcs		

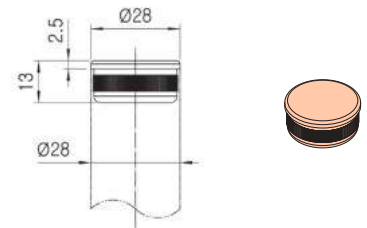

AC2809N Aluminum Cap



Part No.	Material	Pipe	Diameter	Remark
AC2809N	Aluminum	Coated Pipe	Ø28 x t0.9	
AC2814N		Coated Pipe	Ø28 x t1.4	
Weight		0.024kg		
Q'ty/Box		200pcs		

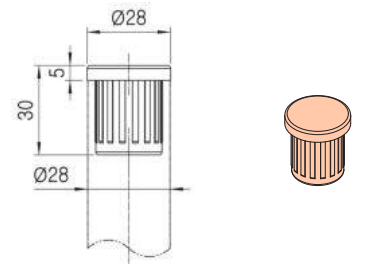

OB28AN Threaded Insert



Part No.	Material	Pipe	Diameter	Remark
OB28AN	Steel (WZ)	All Pipe	Ø28	1/2"-12N
OB28BN				M12-P1.75
Weight		0.045kg		
Q'ty/Box		200pcs		

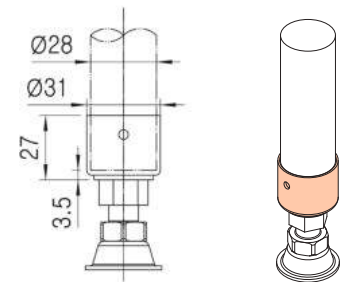

ACCESSORIES THREADED INSERT & CAP

Unit : mm

RF-01 Rubber Foot



Part No.	RF-01	RF-01E
Material	Rubber	
Weight	0.035kg	
Q'ty/Box	250pcs	
Remark	Dark Gray	ESD(BK)

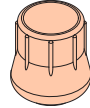
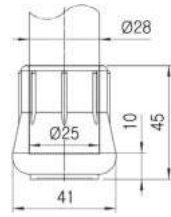

RF-02 Rubber Foot



Part No.	RF-02	RF-02 (Soft)	RF-02 (ESD)
Material	Rubber		
Weight	0.011kg		
Q'ty/Box	450pcs		
Remark	Black		

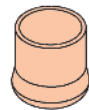
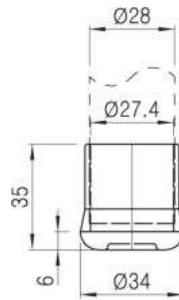

Threaded Insert for Aluminum Rack



Unit : mm

Image	Part No	"A" Detail	Application	Colors	Threaded Spec	Material	Configuration
	BA2800A	-	Ø28	Gray	1/2"-12N	Aluminum	
	BA2800B				M12-P1.75		
	BA2818E	-	Ø28	White	M16-P2.0	Steel	
<p>Shape of classification "A"</p>	BA280LA	○	Ø28	White	1/2"-12N	Steel	
	BA280LB	□			M12-P1.75		
	BA280LD	⬡			M10-P1.5		
	BA280LE	○			M8-P1.25		
<p>STS Nut</p> <p>Housing</p>	BP2800H	-	Ø28	Gray	Housing	Plastic	
	Nut			White	M12-P1.75		
<p>Shape of classification "A"</p>	BA3300A	○	Ø33	White	1/2"-12N	Steel	
	BA3300B	□			M12-P1.75		
	BA3300D	⬡			M10-P1.5		
<p>Shape of classification "A"</p>	BA4300A	○	Ø43	Gray	1/2"-12N	Aluminum	
	BA4300B	□			M12-P1.75		
	BA4300D	⬡			M10-P1.5		
<p>STS Nut</p> <p>Housing</p>	BP4300H	-	Ø43	Gray	Housing	Plastic	
	Nut			White	1/2"-12N		

ACCESSORIES THREADED INSERT & CAP

Threaded Insert for AL Profile

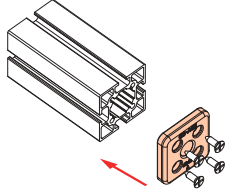
Unit : mm

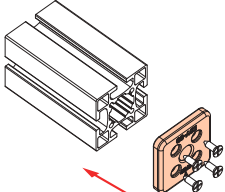
Image	Part No	"A" Detail	Application	Colors	Threaded Spec	Material	Configuration
	BA4040A	-	40x40	Gray	1/2"-12N	Aluminum	
	BA4040B				M12-P1.75		
	BA4545A	-	45x45	Gray	1/2"-12N	Aluminum	
	BA4545B				M12-P1.75		

ACCESSORIES PLASTIC CHANNEL

Material-PVC

L-Type

Unit : mm

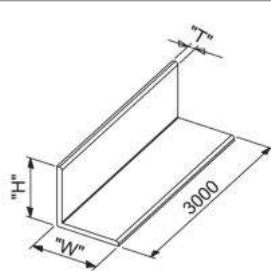
Part No		Thickness	H	W	Weight (kg)	Configuration
Normal	ESD					
AL-1	EAL-1	3	30	50	0.370	
AL-2	EAL-2	4	30	60	0.525	
AL-9	EAL-9	4	30	75	0.618	
AL-5B	EAL-5B	4	50	50	0.544	
AL-6B	EAL-6B	4	50	75	0.656	
AL-8	EAL-8	4	50	100	0.886	
AL-7B	EAL-7B	4	50	150	1.116	
AL-10	EAL-10	4	50	200	1.512	
AL-4	EAL-4	4	80	90	0.978	
AL-5	EAL-5	5	50	50	0.590	
AL-6	EAL-6	5	50	75	0.884	
AL-7	EAL-7	5	50	150	1.510	

T-Type

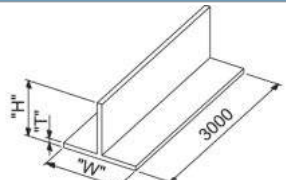
Part No		Thickness	H	W	Weight (kg)	Configuration
Normal	ESD					
AT-1	EAT-1	4	50	100	0.904	
AT-2	EAT-2	4	100	60	0.906	
AT-3	EAT-3	4	150	60	1.145	

U-Type

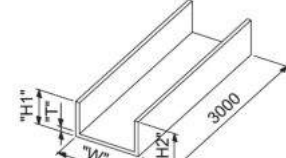
Part No		Thickness	W1	W2	H1	H2	Weight (kg)	Configuration
Normal	ESD							
AU-1	EAU-1	3	36	-	36	36	0.454	
AU-2	EAU-2	3	55	-	30	40	0.572	

S-Type

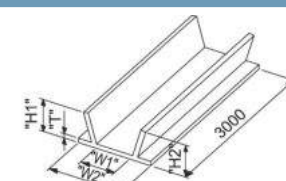
Part No		Thickness	W1	W2	H1	H2	Weight (kg)	Configuration
Normal	ESD							
AS-1	EAS-1	4	32	70	34	25	0.772	
AS-2	EAS-2	5	22	60	30	30	0.580	
AS-3	EAS-3	4	17	50	30	30	0.800	

Pipe-Cover

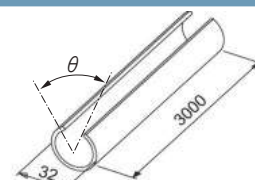
Part No		Thickness	θ	-	-	-	Weight (kg)	Configuration
Normal	ESD							
PC-01	EPC-01	2.5	75°	-	-	-	0.320	
PC-02	EPC-02	2.5	135°	-	-	-	0.310	

Unit : mm

PFG-28A Panel Frame Guide



Material	TPU
Weight	0.022kg
Q'ty/Box	450pcs

* Color : Blue

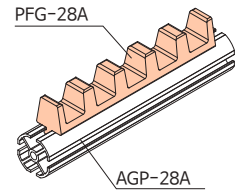
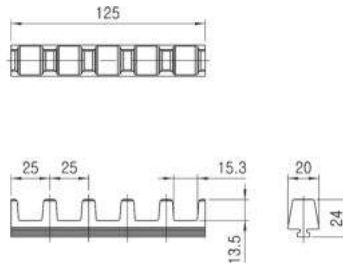

PFG-28B Panel Frame Guide



Material	TPU
Weight	0.023kg
Q'ty/Box	450pcs

* Color : Yellow

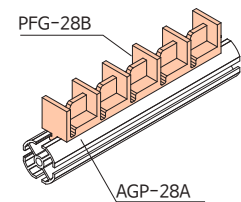
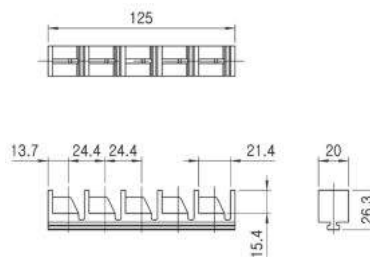

PFG-28C Panel Frame Guide



Material	TPU
Weight	0.022kg
Q'ty/Box	450pcs

* Color : Blue

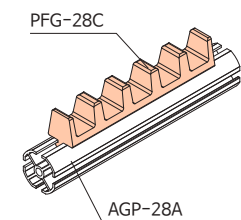
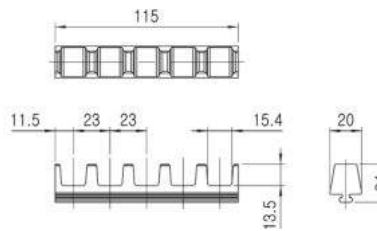

PFG-28D Panel Frame Guide



Material	TPU
Weight	0.030kg
Q'ty/Box	450pcs

* Color : Gray

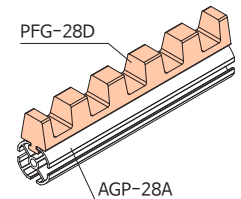
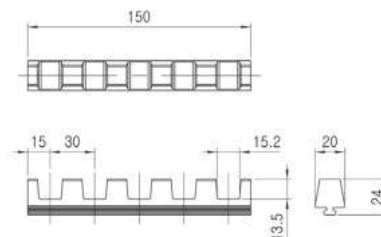

PFG-28E Panel Frame Guide



Material	TPU
Weight	0.018kg
Q'ty/Box	450pcs

* Color : Yellow, Blue

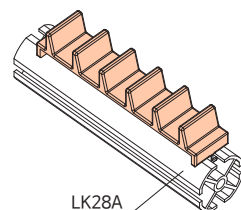
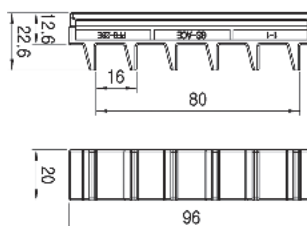

Unit : mm

CFG-28A Chassis Frame Guide



Material	TPU
Weight	0.021kg
Q'ty/Box	450pcs

* Color : Gray

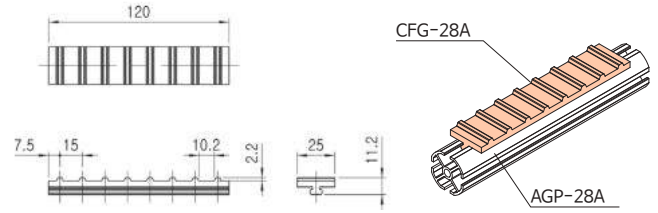

PFG-P20/40 Panel Frame Guide



<PFG-P20>

Material	TPU
Weight	0.042kg
Q'ty/Box	200pcs

<PFG-P40>

Material	TPU
Weight	0.035kg
Q'ty/Box	200pcs

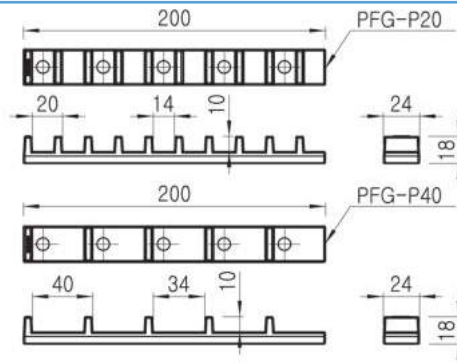

ACCESSORIES FASTENERS

Fastener Type	Part No	Item	Spec	Colors	Usage
	TN06W	T-Nut	M6	White	Metal Joint
	TN06B			Black	
	SW04W	Spring Washer	M4	White	Bolt
	SW05W		M5		
	SW06W		M6		
	SW08W		M8		
	SW10W		M10		
	SW13W		M12		
	PW04W	Flat Washer	M4	White	Bolt
	PW05W		M5		
	PW06W		M6		
	PW08W		M8		
	PW10W		M10		
	NN04W	Nylon Nut	M4	White	Bolt
	NN05W		M5		
	NN06W		M6		
	NN08W		M8		
	NN10W		M10		
	NN12W		M12		
	NN05W-i		Inch Nylon Nut		
		N04W	Nut	M4	White
N05W		M5			
N06W-55		M6			
N08W		M8			
N10W		M10			
N12W		M12			

Fastener Type	Part No	Item	Spec	Colors	Usage
	M0610W	M6x10	P1.0	White	Metal Joint
	M0610B			Black	
	M0612W	M6x12		White	
	M0615W	M6x15			
	M0625W	M6x25	P 1.0	White	Metal Joint
	M0625B			Black	
	M0630W	M6x30		White	
	M0630B			Black	
	M0830W	M8x30	P1.25	White	AL Joint
	M0840W	M8x40			
	M1020W	M10Bolt	P1.25	White	Caster
	M1225W	M12Bolt			
	GM835W	M8Bolt	P1.25	White	Caster
	GM840W				Base Lock Metal
	GM845W				
	GM850W				
	GM860W				
	GM870W				
					
Gi0575W-12		inch Bolt 75mm	Base Lock Metal		
	HM0615	Knob Bolt	P1.0	Black	Metal Joint
	HM0620				
	HM0630				

Unit : mm



- Weight : 0.005kg
- Q'ty/Box : 1000EA

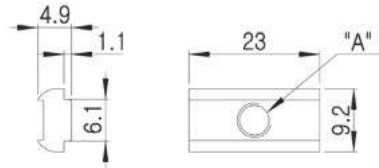

Part No.	"A" Tap	Remark
IN304	M4	
IN305	M5	
IN306	M6	

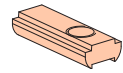

- Weight : 0.005kg
- Q'ty/Box : 1000EA

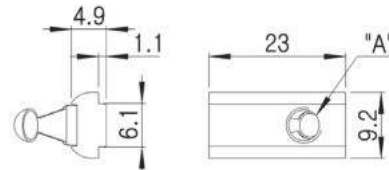

Part No.	"A" Tap	Remark
SN304	M4	
SN305	M5	
SN306	M6	

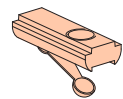

- Weight : 0.008kg
- Q'ty/Box : 1000EA

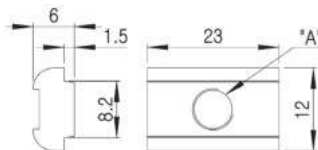

Part No.	"A" Tap	Remark
IN404	M4	
IN405	M5	
IN406	M6	
IN408	M8	

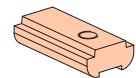

- Weight : 0.010kg
- Q'ty/Box : 1000EA

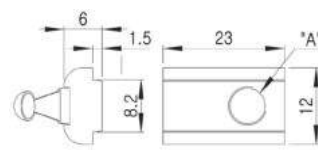

Part No.	"A" Tap	Remark
SN404	M4	
SN405	M5	
SN406	M6	
SN408	M8	

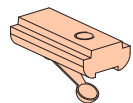

ACCESSORIES HAND CUTTER

* Surface Treatment - WZ

Unit : mm

HC-1 Pipe Hand Cutter

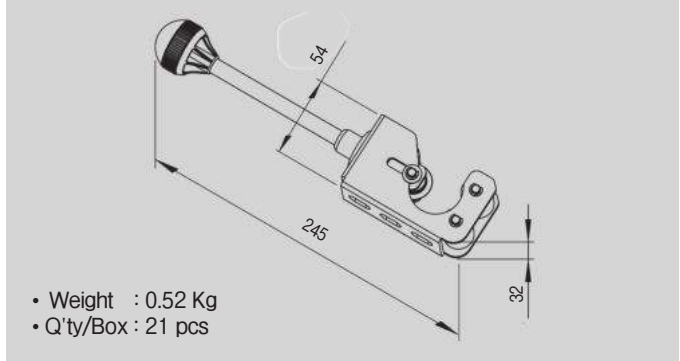

- Weight : 0.52 Kg
- Q'ty/Box : 21 pcs

PK-1 Pipe Cutter Knife

Include Knife(PK-1)

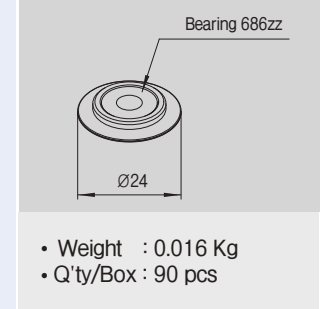

Include Bearing

- Weight : 0.016 Kg
- Q'ty/Box : 90 pcs

* Knife for Pipe Hand Cutter (HC-1)

Range	O.D \varnothing 26~ \varnothing 30	Remark
Material & Thickness of Pipe		
- STS Pipe	0.1t~1.4t	
- ECCO Pipe	0.7t~2.0t	
- Coated Pipe	0.7t~2.0t	

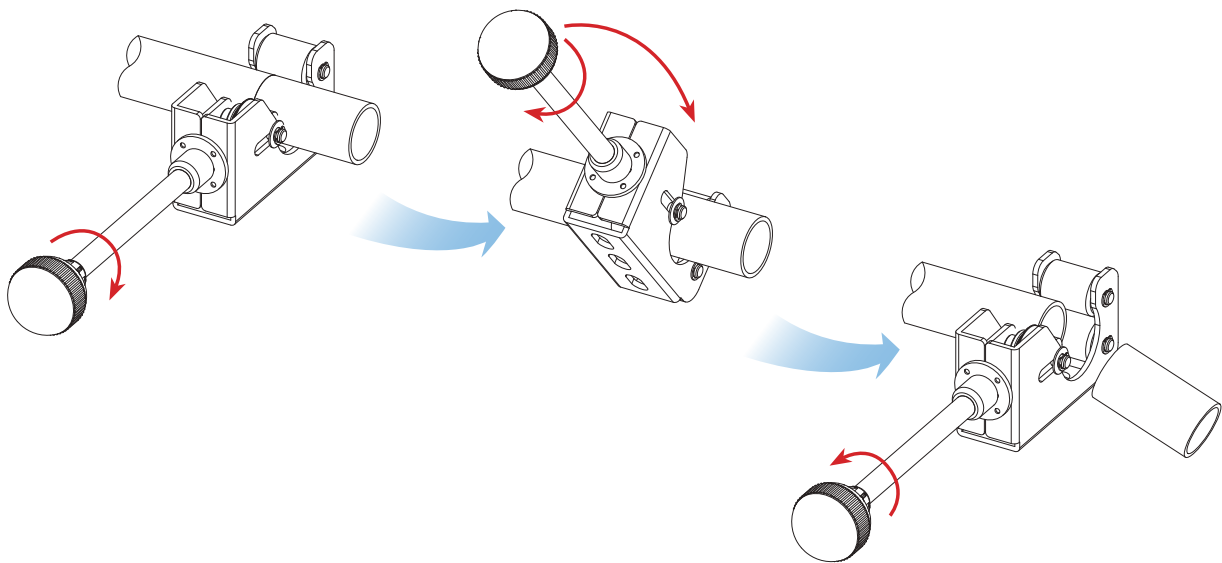

LIFT TABLE

※ Feature

User can easily move the table of the lift table in accordance with the height of him or her.
Also, the user will plainly modify the structures of the lift table.

※ Specification

Model	LT-500	LT-750
TABLE SIZE	800X600	1200x800
STROKE	MAX. 200mm	
OPERATION	MANUAL	
LOAD	10Kg	



※ B.O.M (LT-500)

PART NO.	PART NAME	UNIT	Q'TY	REMARK
L-500	RAIL	EA	2	
TM16-500	SCREW ASS'Y	EA	1	
GAP-21A	NUT BLOCK	EA	1	
GAP-22A	BEARING BLOCK	EA	1	
BB01	BALL BEARING	EA	4	
HD-80	HANDLE	SET	1	
S2807	PIPE	MT	-	Condition of the sizes
GAP-4P	INNER CAP	EA	4	
GAP-12	SLEEVE	EA	10	
GA-1S	JOINTS	SET	10	
GA-12S	JOINTS	SET	10	
PS-A	JOINTS	SET	2	
BS07B	THREADED INSERT	EA	8	
M1225W	BOLT	EA	8	
SW13W	WASHER	EA	4	

※ LT-750 requires L-750 rail

※ Dimension

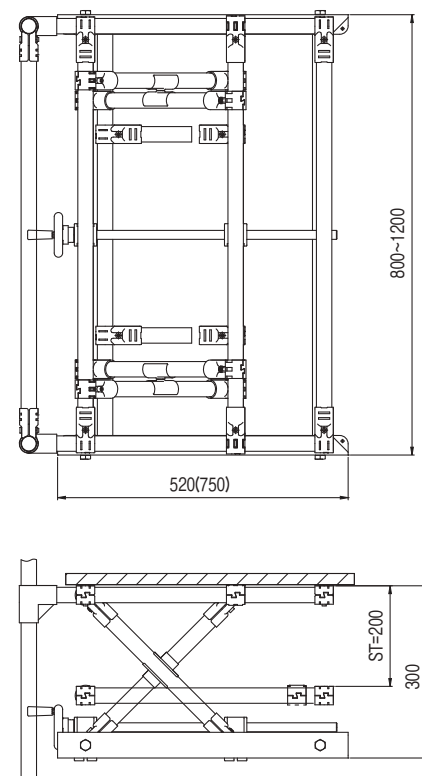

LIFT TABLE COMPONENTS

L-500 Rail

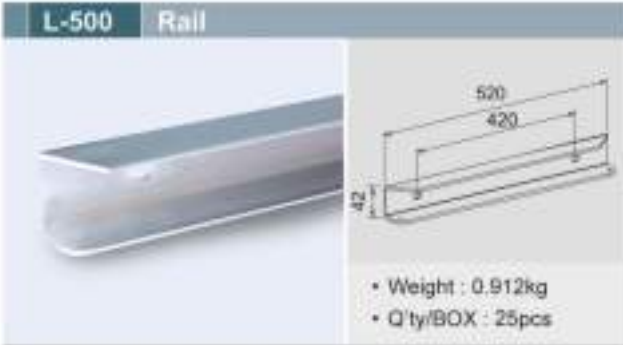

L-750 Rail

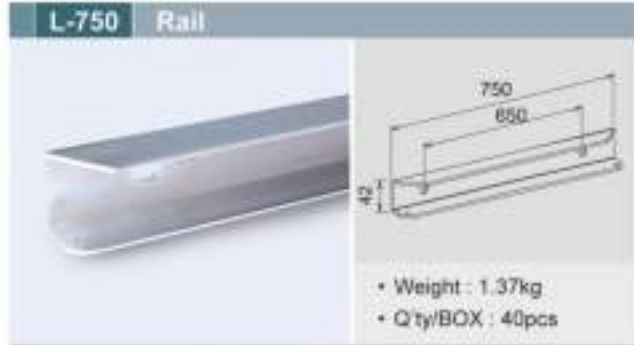

TM16-500 Screw ass'y



BB01 Ball bearing



GAP-21A Nut block

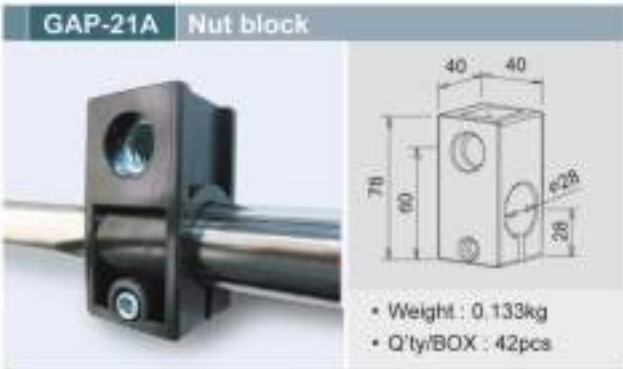

GAP-22A Bearing block



HD-80 Handle



HD-80 Specification

Item	Spec	Q'ty	Remark
Wheel	Ø80 x M06	1	
Handle	M6,L=60	1	
Key	4 x 4 x 15	1	
Wrench Bolt	M4 x 10	2	
SNAP RING	SN12	1	

Unit : mm

MB-15 Monitor Bracket (VESA Hole Standard)



Material	Steel
Weight	0.350kg
Q'ty/Box	20pcs

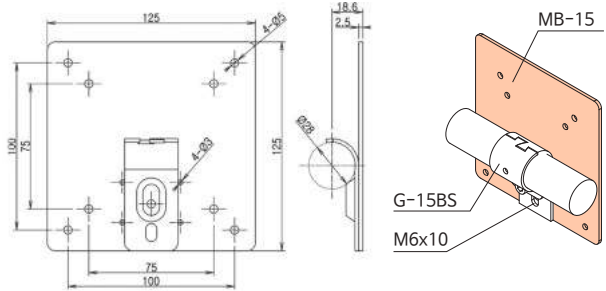

Applications of Monitor Bracket

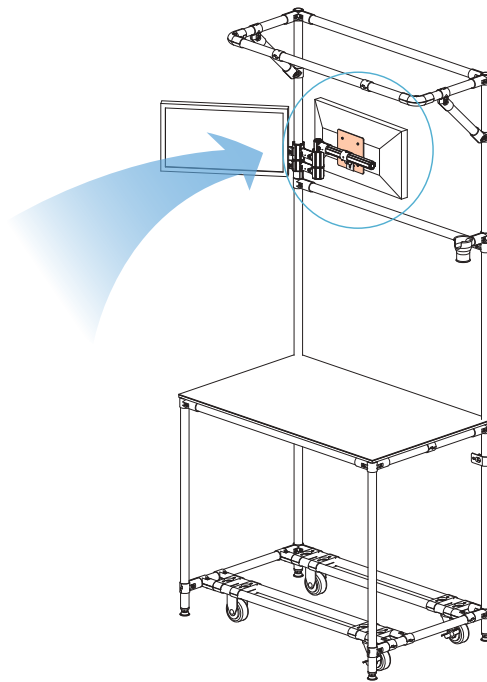
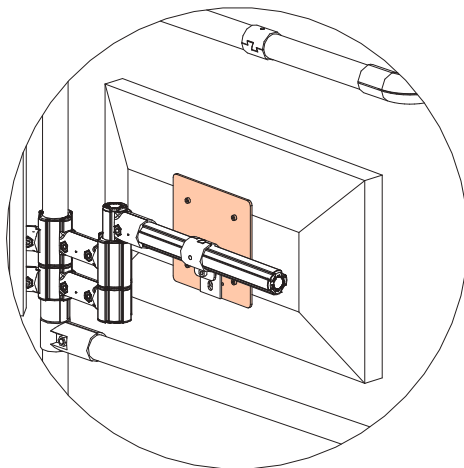

WR-19/22 Spanner for Caster



Material	Steel
Weight	0.091kg
Q'ty/Box	50pcs

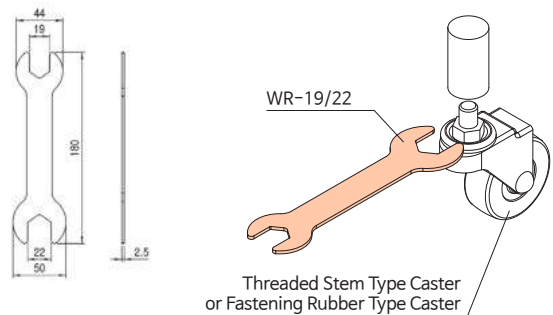

Unit : mm

DL-15 Door Latch



Material	Steel
Weight	0.305kg
Q'ty/Box	40pcs

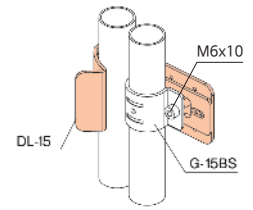
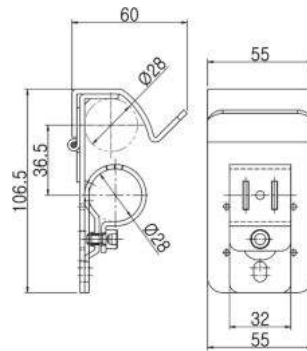

Applications of Door Latch

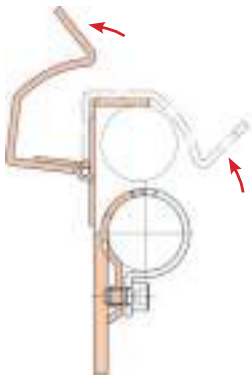

OPEN

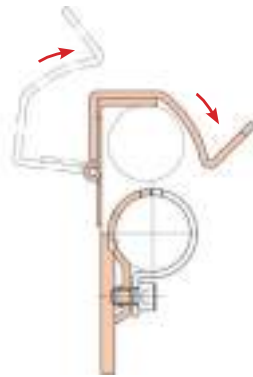

CLOSE

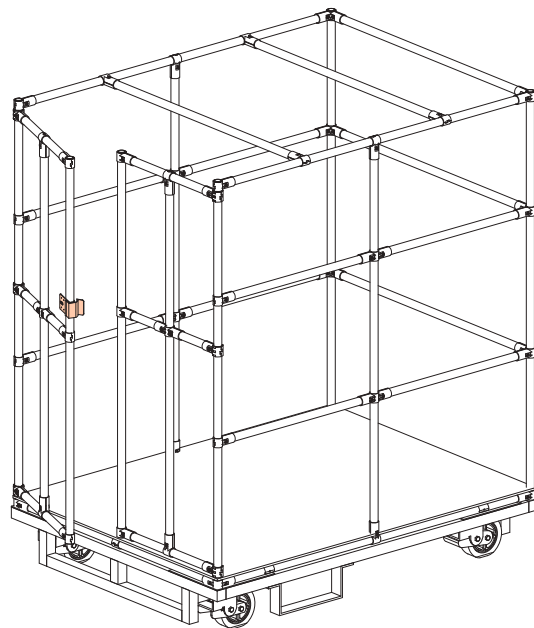

Unit : mm

TC-28 Tool Cap



Material	Rubber
Weight	0.012kg
Q'ty/Box	450pcs

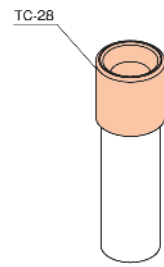
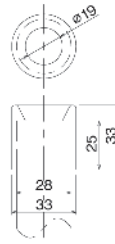

PS-A Rotating Cross Joint



Material	Steel
Weight	0.128kg
Q'ty/Box	96pcs

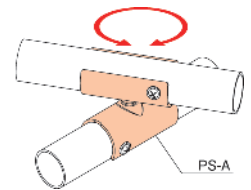
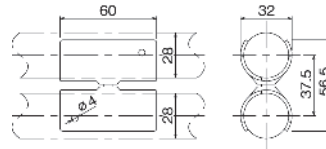

PS-B Rotating Cross Joint



Material	Steel
Weight	0.104kg
Q'ty/Box	96pcs

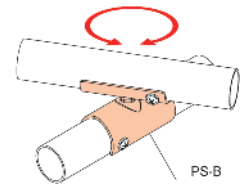
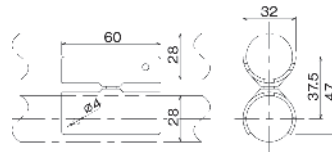

PS-C Rotating Cross Joint



Material	Steel
Weight	0.105kg
Q'ty/Box	70pcs

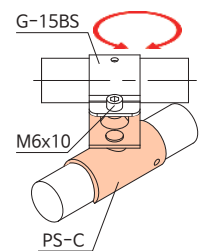
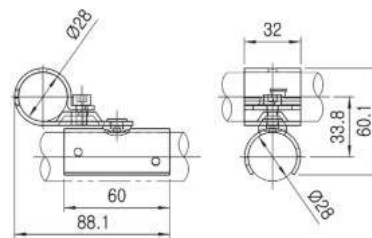

SC-2845 Shaft Cylinder

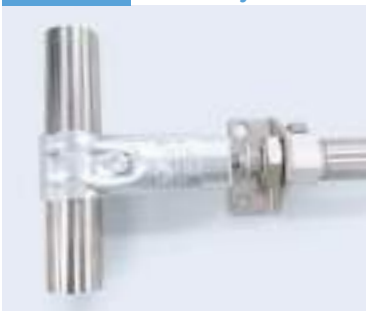

Material	Steel
Weight	0.190kg
Q'ty/Box	90pcs

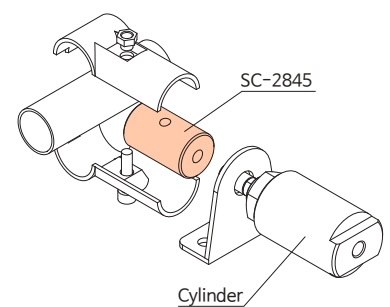
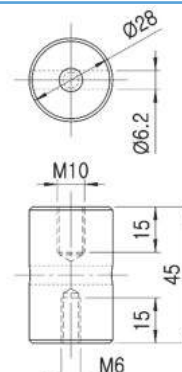

ACCESSORIES OTHERS

* Surface Treatment - WZ

Unit : mm

RCP-32 Roller Conveyor Pulley Bearing



Material	Plastic
Weight	0.017kg
Q'ty/Box	100pcs

* Color : Blue

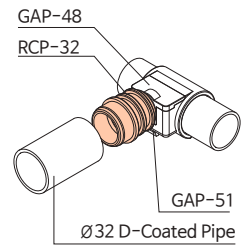
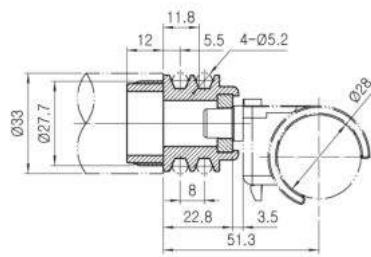

BUSH-12 Sleeve Bushing (Metal)



Material	Steel
Weight	0.035kg
Q'ty/Box	120pcs

Joint for assembly :
G-12S, G-17S, G-18S,
G-24S, G-25C, G-22S

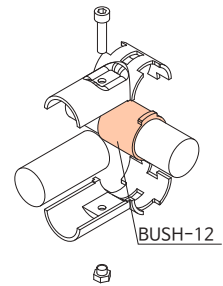
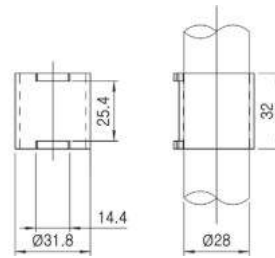

FB-28 Folding Bracket



Material	Steel
Weight	0.155kg
Q'ty/Box	50pcs

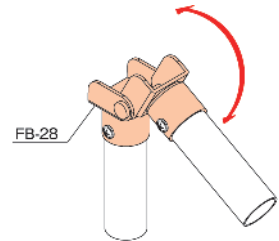
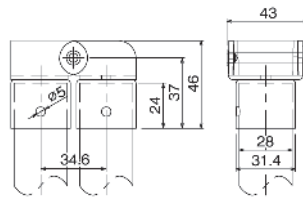

MCY-304A Metal Stopper



Material	Steel
Weight	0.038kg
Q'ty/Box	150pcs

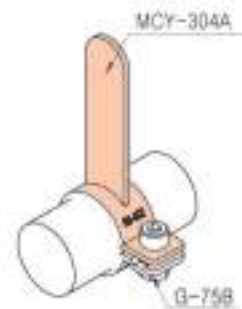
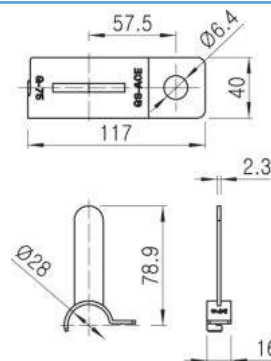

MCY-304B Name Plate Holder



Material	Steel
Weight	0.021kg
Q'ty/Box	250pcs

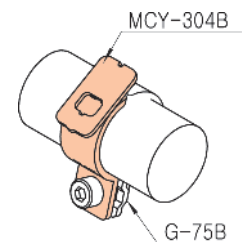
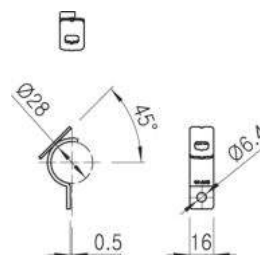

ACCESSORIES OTHERS

* Surface Treatment - WZ

Unit : mm

AD-SM Stanchion Mount Single



* Including M6 Bolt

Material	Steel
Weight	0.198kg
Q'ty/Box	20pcs

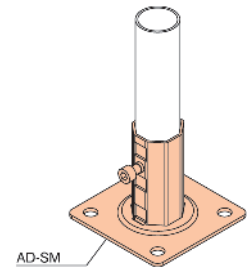
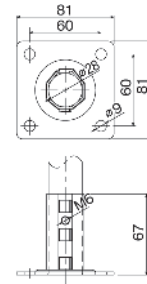

AP-50 Anchor Plate (Prevention from moving by shake & shock)



Material	Steel
Weight	0.052kg
Q'ty/Box	220pcs

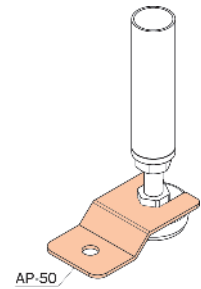
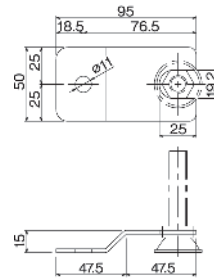

AP-60 Anchor Plate



Material	P/D
Weight	0.052kg
Q'ty/Box	220pcs

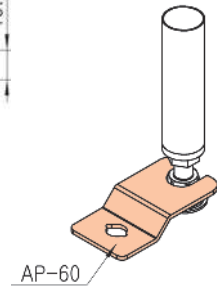
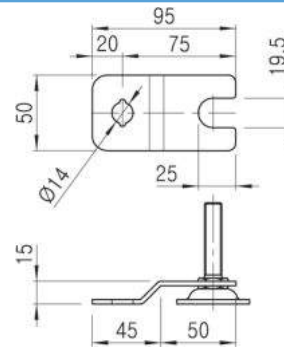

MCY-306A Pipe Anchor Bracket



Material	P/D
Weight	0.112kg
Q'ty/Box	24pcs

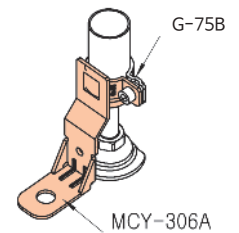
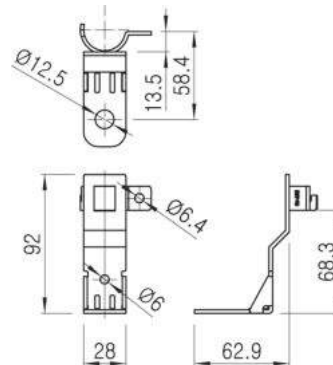

Applications of AP-50



ACCESSORIES OTHERS

* Surface Treatment - WZ

Unit : mm

HC28A Hole Cup-A



Material	Steel
Weight	0.300kg
Q'ty/Box	20pcs

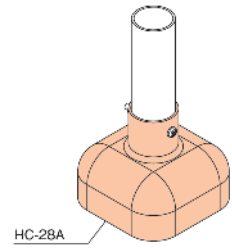
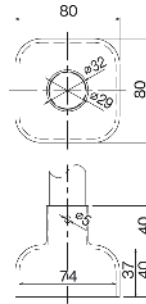

HC40 Hole Cup



Material	Steel
Weight	0.394kg
Q'ty/Box	-

Can be used to stack 2nd floor Trolley with welding round or square pipe

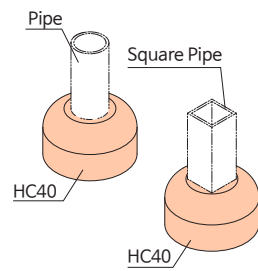
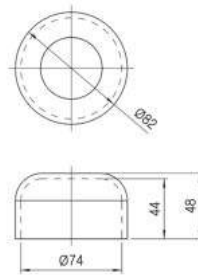

Applications of Hole Cup

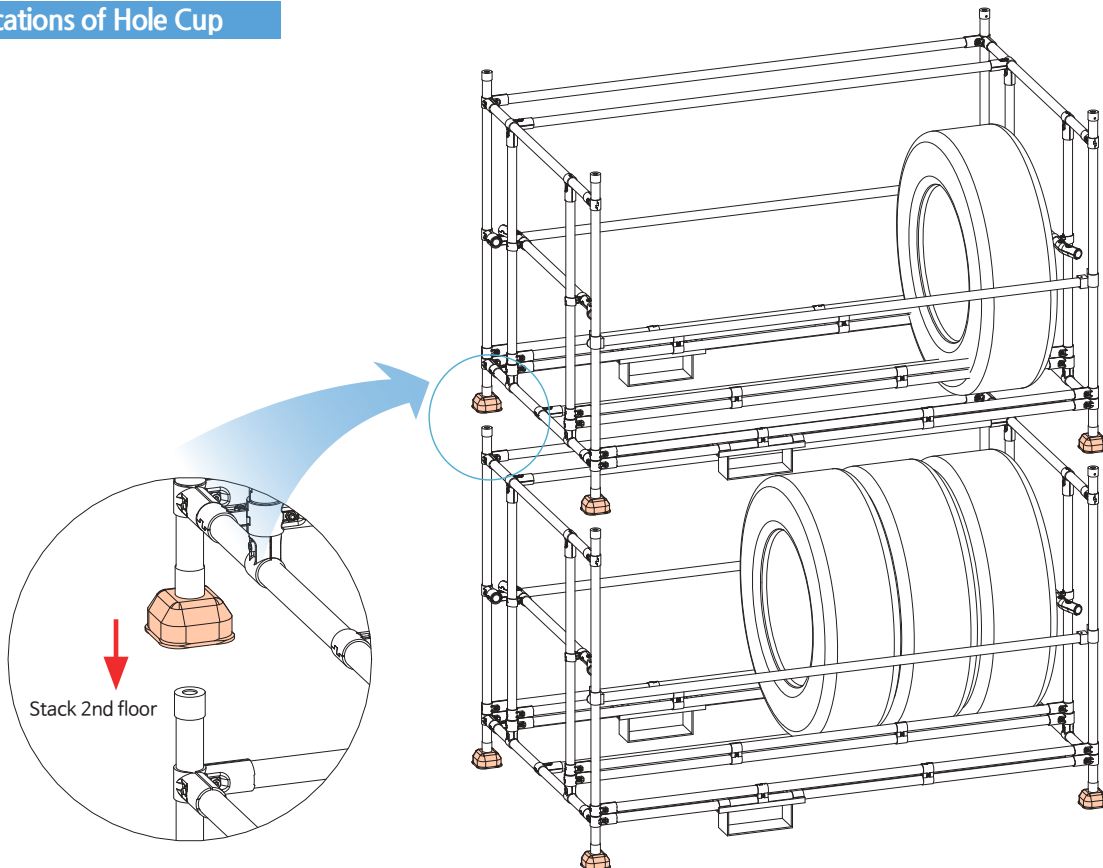

* Surface Treatment - WZ

Unit : mm

PHR-28 Hang Roller



Material	Steel
Weight	0.045kg
Q'ty/Box	50pcs

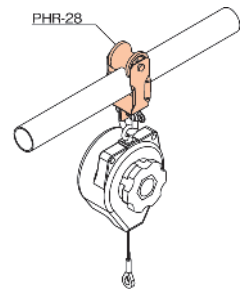
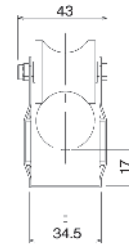
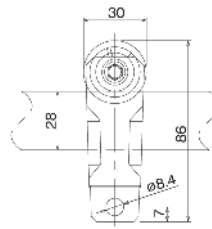

Applications of Hang Roller

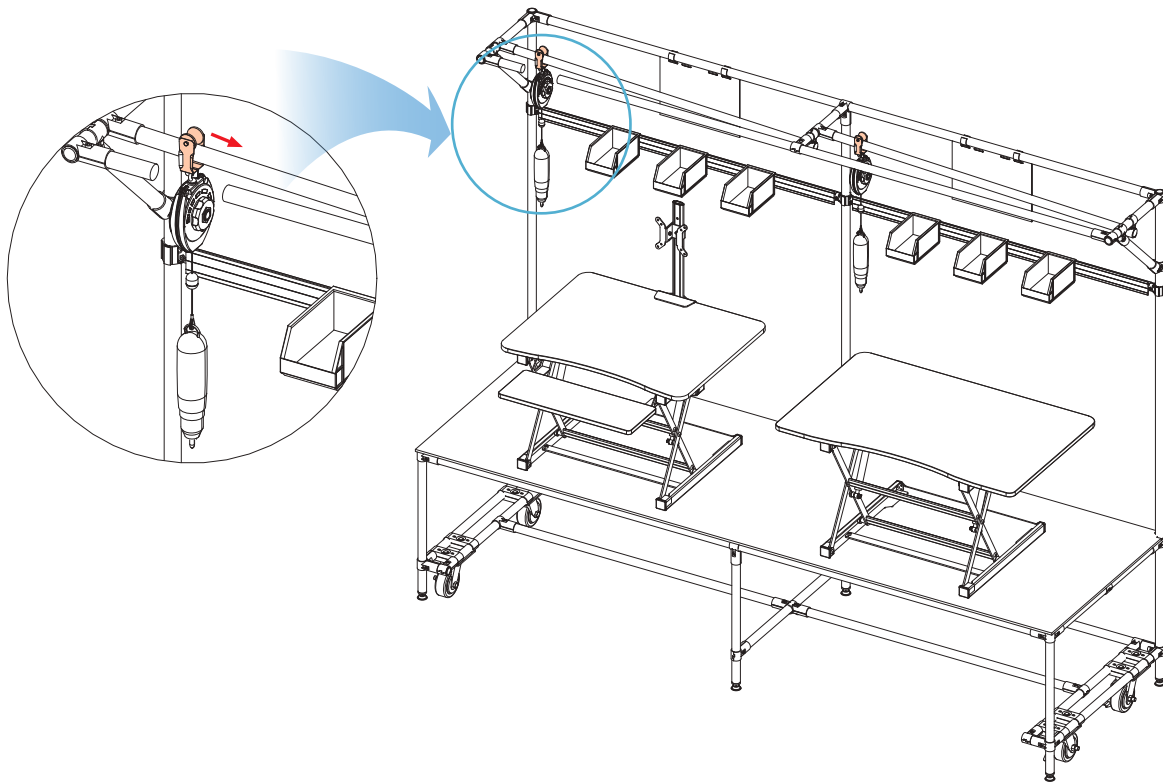

ACCESSORIES OTHERS

* Surface Treatment - WZ

Unit : mm

HG-D Hinge Metal



Material	Steel
Weight	0.052kg
Q'ty/Box	100pcs

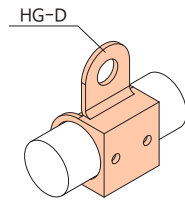
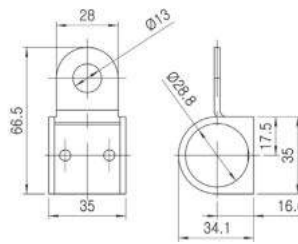

HG-D-BR Hinge Metal



Material	Steel
Weight	0.052kg
Q'ty/Box	100pcs

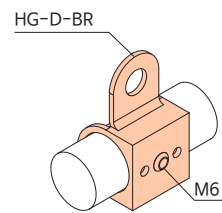
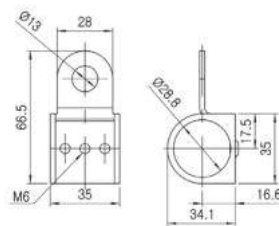

MCY-N302 Corner Bumper



Material	TPU
Weight	0.323kg
Q'ty/Box	150pcs

* Color : Gray

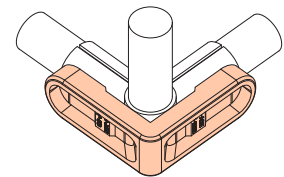
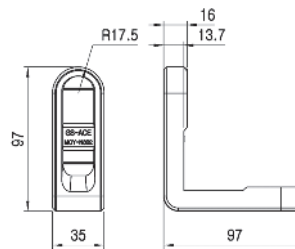

Applications of Hinge Metal & Corner Bumper

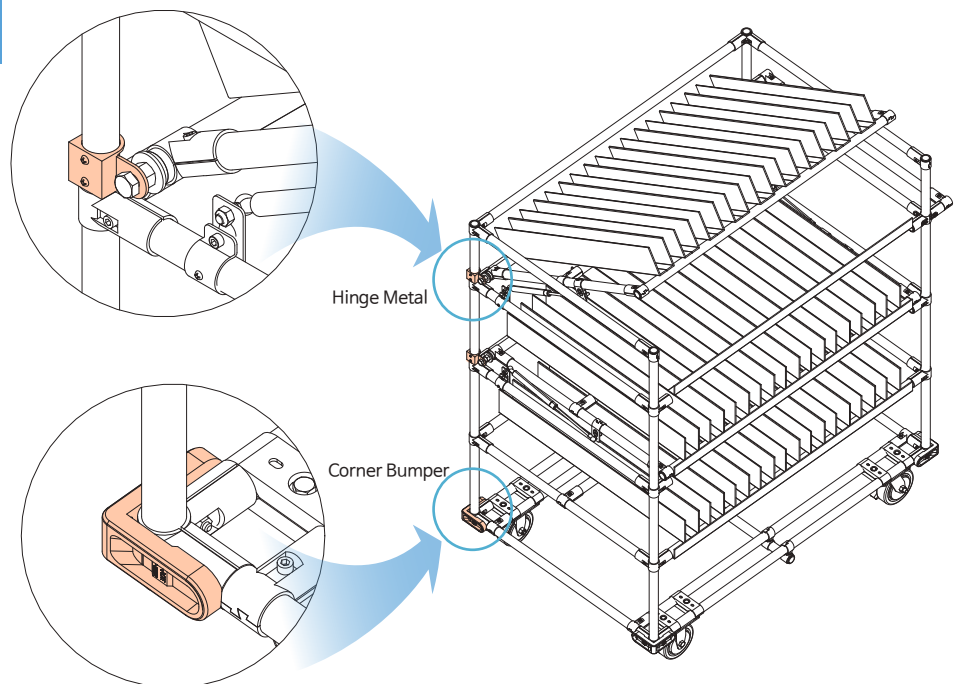

* Surface Treatment - WZ

Unit : mm

RB-2880A Ring Bumper



Material	Rubber
Weight	0.060kg
Q'ty/Box	150pcs

* Color : White

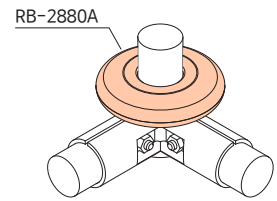
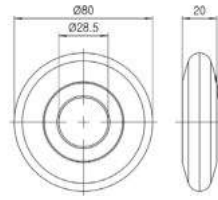

RB-3480A Ring Bumper



Material	Rubber
Weight	0.065kg
Q'ty/Box	150pcs

* Color : Yellow

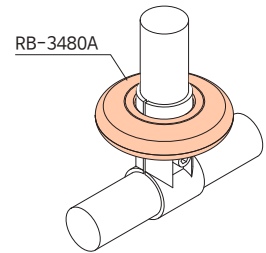
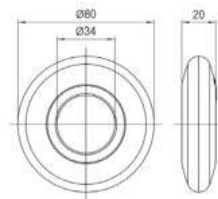

Applications of Ring Bumper (RB-2880A)

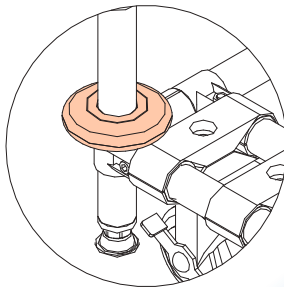

Applications of Ring Bumper (RB-3480A)

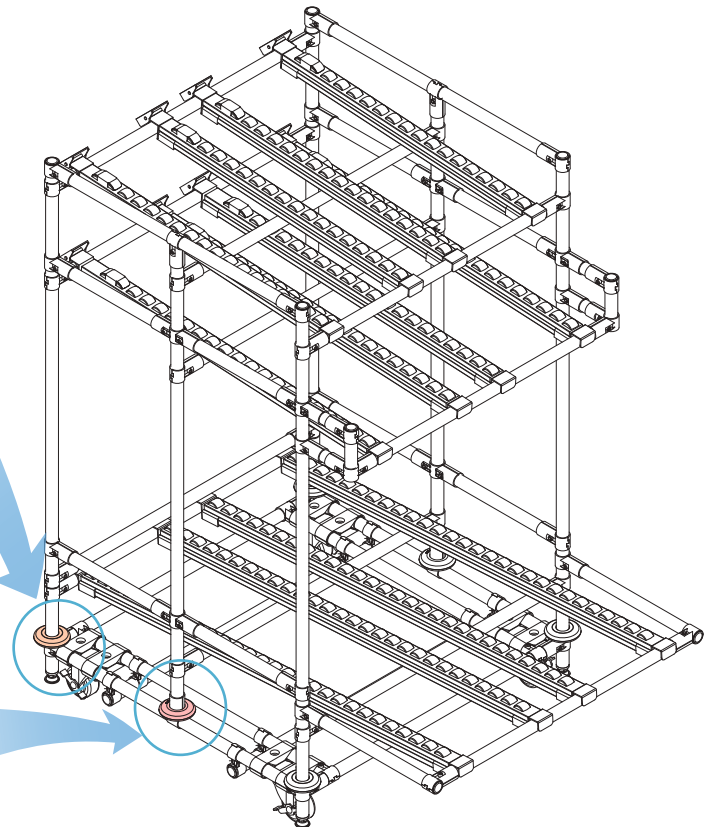
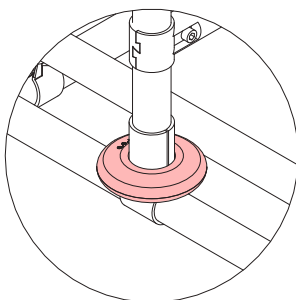

* Surface Treatment - WZ

Unit : mm

WR-200 Wire Rack

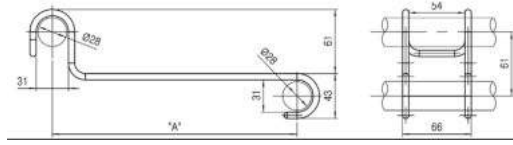

Part No	Pipe	"A"	Weight	Q'ty/Box
WR-200	Ø28	235	0.182kg	25pcs
WR-300		335	0.230kg	80pcs
WR-400		435	0.271kg	30pcs

Applications of Wire Rack

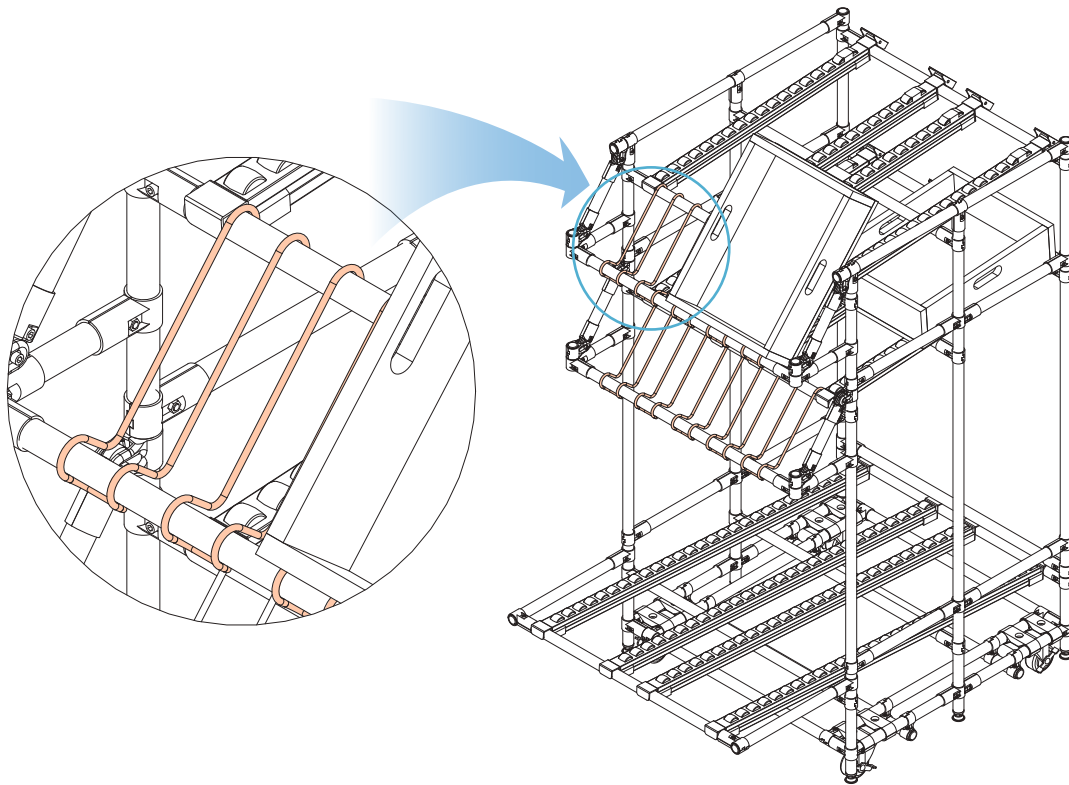

WL-250 Wire Latch



Material	Steel (PVC Coating)
Weight	0.139kg
Q'ty/Box	150pcs

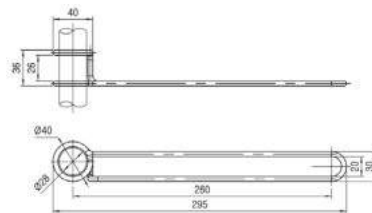

* Surface Treatment - WZ

Unit : mm

LK28A Pipe Connector (Coated Pipe)



Material	Steel
Weight	0.046kg
Q'ty/Box	120pcs

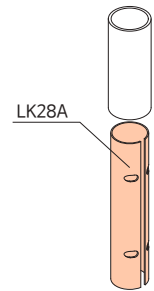
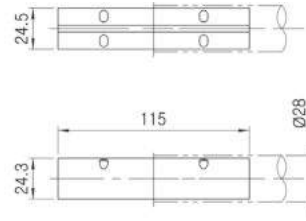

LK28S Pipe Connector (STS/ECCO Pipe)



Material	Steel
Weight	0.046kg
Q'ty/Box	120pcs

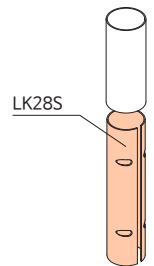
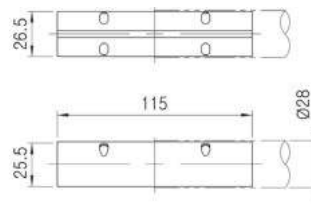

TECHNICAL SPECIFICATIONS

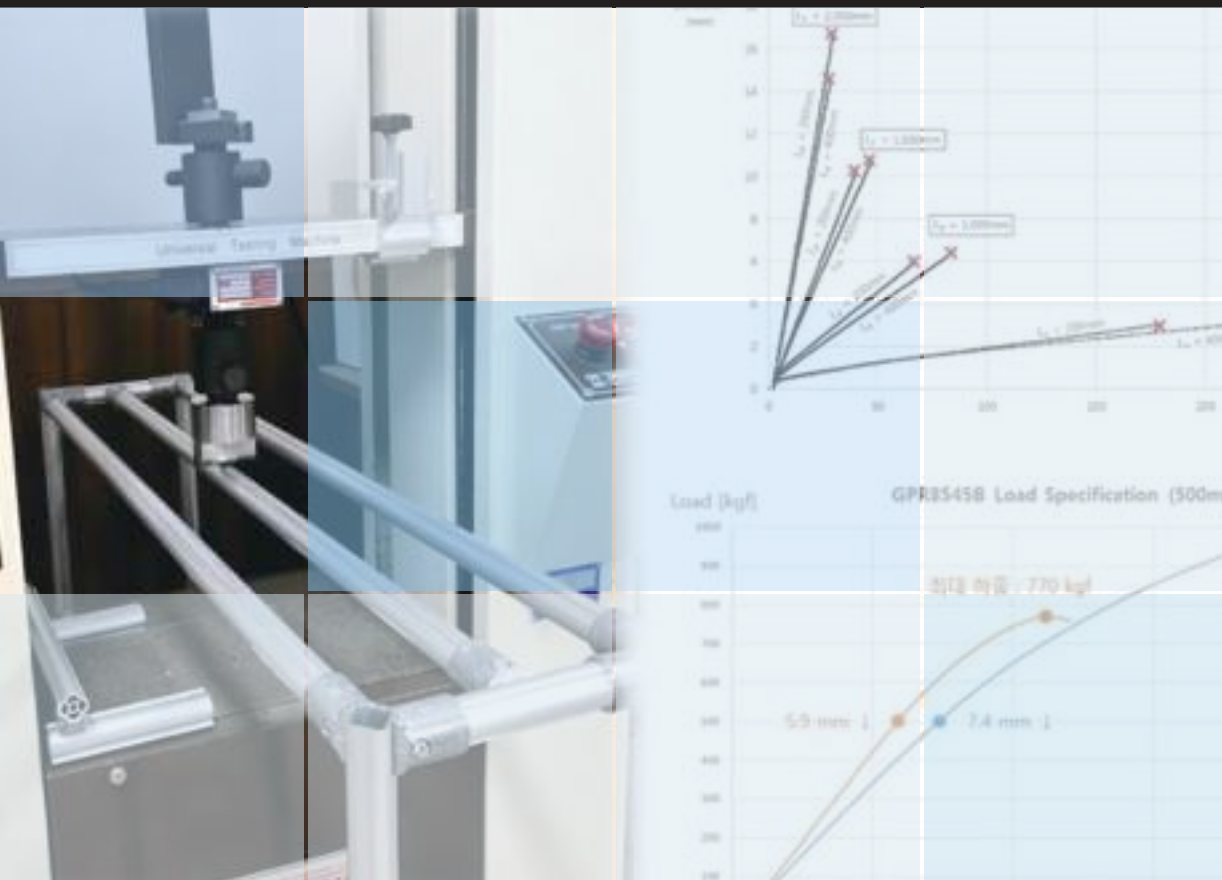

- METAL RACKING SYSTEM
- ALUMINUM RACKING SYSTEM
- ROLLER TRACK SYSTEM

TECHNICAL SPECIFICATIONS METAL RACKING SYSTEM

BENDING STRENGTH FOR PIPE

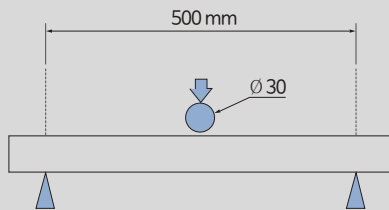

Test Condition

1. Test Speed : 5mm / min
2. Temperature : 23°C

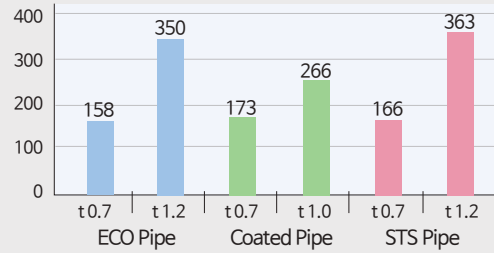

Unit :kgf

Spec. of Pipe	Eco Pipe	Coated Pipe	STS Pipe
Ø28 x t0.7	158	173	166
Ø28 x t1.0	-	266	-
Ø28 x t1.2	350	-	363

HOLDING FORCE

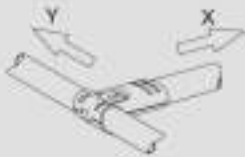

Test Condition

1. Test Speed : 5mm / min
2. Temperature : 23°C

Classification	Coated Pipe		Stainless Steel Pipe	
	Ø28 x t0.7	Ø28 x t1.0	Ø28 x t0.7	Ø28 x t1.2
Direction : X	More Than 80kg	More Than 80kg	More Than 80 kg	More Than 80 kg
Direction : Y	More Than 80kg	More Than 80kg	More Than 80 kg	More Than 80 kg

DETERMINING STANDARD PIPE LENGTH

Metal Joint

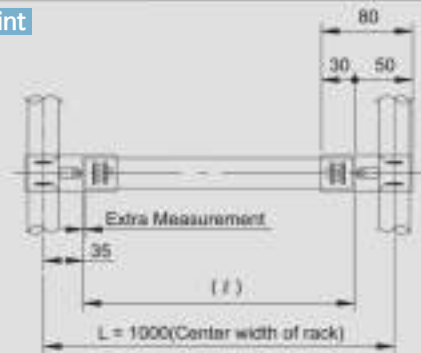

$$l = 1000 - (70+2) = 928(\text{mm})$$

Case of Ø28mm

1000mm	Center Measurement (L)
-70mm	Pipe Length Inside Joint (35mm x 2)
-2mm	Extra Measurement (2mm~5mm)
928mm	Pipe Length (l)

Plastic Joint

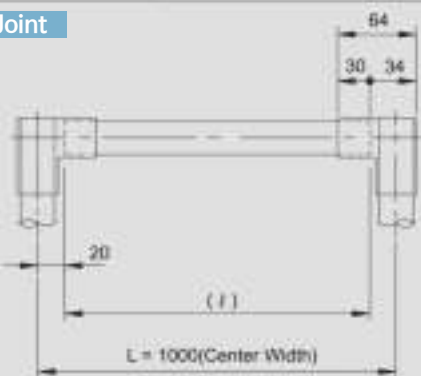

$$l = 1000 - (40+2) = 958(\text{mm})$$

Case of Ø28mm





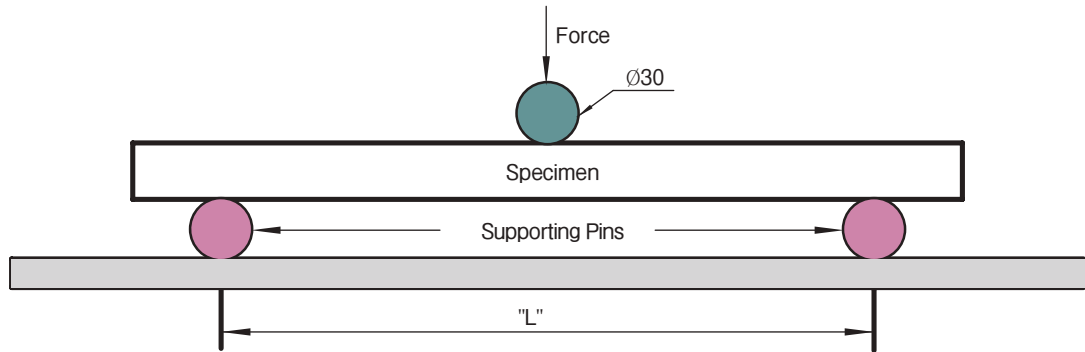



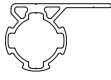
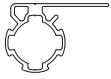
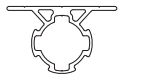
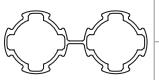
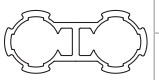
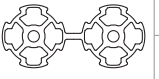

1000mm	Center Measurement (L)
-40mm	Pipe Length Inside Joint (20mm x 2)
-2mm	Extra Measurement (2mm~5mm)
958mm	Pipe Length (l)

PIPE BENDING STRENGTH

















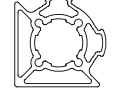

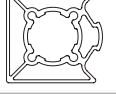
External Size	Part No.	TYPE	Concentrated Load (kgf)		Weight (g/m)	Second Section Moment	4M Packing quantity			
			L=500mm	L=1000mm			pcs/Bag	Bag/Pallet	pcs/Pallet	
Ø28	AP2812		225	113	382	Ix : 1.03x10 ⁴ mm ⁴ ly : 1.03x10 ⁴ mm ⁴	10 pcs	100 Bag	1000 pcs	
	AP2820		X→	248	122	450	Ix : 1.32x10 ⁴ mm ⁴ ly : 1.06x10 ⁴ mm ⁴	10 pcs	100 Bag	1000 pcs
			Y↓	286	143					
	AP2829		298	148	500	Ix : 1.33x10 ⁴ mm ⁴ ly : 1.33x10 ⁴ mm ⁴	10 pcs	100 Bag	1000 pcs	
	AP2812H		405	185	741	Ix : 1.54x10 ⁴ mm ⁴ ly : 1.54x10 ⁴ mm ⁴	8 pcs	100 Bag	800 pcs	
	AR2812		213	114	379	Ix : 1.13x10 ⁴ mm ⁴ ly : 1.13x10 ⁴ mm ⁴	10 pcs	100 Bag	1000 pcs	
	AR2820		247	132	446	Ix : 1.30x10 ⁴ mm ⁴ ly : 1.30x10 ⁴ mm ⁴	10 pcs	100 Bag	1000 pcs	
	AR2829		297	154	496	Ix : 1.46x10 ⁴ mm ⁴ ly : 1.46x10 ⁴ mm ⁴	10 pcs	100 Bag	1000 pcs	
	AL2813		171	95	335	Ix : 1.05x10 ⁴ mm ⁴ ly : 1.05x10 ⁴ mm ⁴	10 pcs	100 Bag	1000 pcs	
	AL2818		242	127	401	Ix : 1.21x10 ⁴ mm ⁴ ly : 1.21x10 ⁴ mm ⁴	10 pcs	100 Bag	1000 pcs	
	ACF2812		214	107	358	Ix : 1.57x10 ⁴ mm ⁴ ly : 1.34x10 ⁴ mm ⁴	6 pcs	150 Bag	900 pcs	
	ALS2812		168	85	372	Ix : 1.82x10 ⁴ mm ⁴ ly : 1.21x10 ⁴ mm ⁴	6 pcs	150 Bag	900 pcs	
	AFS2810		160	89	375	Ix : 0.89x10 ⁴ mm ⁴ ly : 0.89x10 ⁴ mm ⁴	10 pcs	100 Bag	1000 pcs	
	AFS2812		178	99	408	Ix : 1.06x10 ⁴ mm ⁴ ly : 1.06x10 ⁴ mm ⁴	10 pcs	100 Bag	1000 pcs	
AQ2812		181	100	374	Ix : 1.09x10 ⁴ mm ⁴ ly : 1.10x10 ⁴ mm ⁴	10 pcs	100 Bag	1000 pcs		

TECHNICAL SPECIFICATIONS ALUMINUM RACKING SYSTEM

External Size	Part No.	TYPE	Concentrated Load (kgf)		Weight (g/m)	Second Section Moment	4M Packing quantity			
			L=500mm	L=1000mm			pcs/Bag	Bag/Pallet	pcs/Pallet	
Ø28	ALF2812		290	163	655	lx : 3.46x10 ⁴ mm ⁴ ly : 3.63x10 ⁴ mm ⁴	6 pcs	150 Bag	900 pcs	
	ALF2812B		412	202	614	lx : 3.50x10 mm ⁴ ly : 2.95x10 mm ⁴	6 pcs	150 Bag	900 pcs	
	ATF2812		370	179	685	lx : 3.72x10 mm ⁴ ly : 3.10x10 mm ⁴	6 pcs	150 Bag	900 pcs	
	AD2812		X→	454	331	761	lx : 2.04x10 mm ⁴ ly : 1.94x10 mm ⁴	5 pcs	100 Bag	500 pcs
			Y↓	432	219					
	AD2829		X→	689	462	1138	lx : 3.09x10 mm ⁴ ly : 2.68x10 mm ⁴	5 pcs	100 Bag	500 pcs
			Y↓	539	270					
	AD2812H		X→	1584	878	1372	lx : 2.40x10 mm ⁴ ly : 3.28x10 mm ⁴	5 pcs	70 Bag	350 pcs
			Y↓	645	304					
	AGP-28A			184	91	479	lx : 0.97x10 mm ⁴ ly : 0.97x10 mm ⁴	10 pcs	100 Bag	1000 pcs
AGP-28B		X→	184	91	499	lx : 1.05x10 mm ⁴ ly : 0.96x10 mm ⁴	10 pcs	100 Bag	1000 pcs	
		Y↓	200	100						
AT2829			265	121	595	lx : 0.95x10 mm ⁴ ly : 1.63x10 mm ⁴	10 pcs	100 Bag	1000 pcs	
ASGP-08			230	120	595	lx : 1.78x10 mm ⁴ ly : 1.10x10 mm ⁴	8pcs	90Bag	720pcs	
Ø33	AP3315		320	165	453	lx : 1.76x10 mm ⁴ ly : 1.76x10 mm ⁴	6 pcs	100 Bag	600 pcs	
	AP3315H		560	255	883	lx : 2.43x10 mm ⁴ ly : 2.43x10 mm ⁴	6 pcs	100 Bag	600 pcs	
Ø43	AP4319C		596	346	803	lx : 5.07x10 mm ⁴ ly : 5.07x10 mm ⁴	6 pcs	60 Bag	360 pcs	
	AP4319H		981	503	1278	lx : 6.18x10 mm ⁴ ly : 6.18x10 mm ⁴	6 pcs	60 Bag	360 pcs	
	AQ4320		600	365	902	lx : 6.16x10 mm ⁴ ly : 6.73x10 mm ⁴	6 pcs	60 Bag	360 pcs	
	AD4319		X→	1043	874	1887	lx : 11.45x104mm ⁴ ly : 6.16x104mm ⁴	2 pcs	90 Bag	180 pcs
Y↓			1391	737						

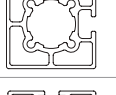
TECHNICAL SPECIFICATIONS ALUMINUM RACKING SYSTEM

External Size	Part No.	TYPE	Concentrated Load (kgf)		Weight (g/m)	Second Section Moment	4M Packing quantity			
			L=500mm	L=1000mm			pcs/Bag	Bag/Pallet	pcs/Pallet	
28X28	ASQ2812A		385	188	566	lx : 1.83x10 ⁴ mm ⁴ ly : 1.33x10 ⁴ mm ⁴	8 pcs	100 Bag	800 pcs	
	ASQ2812B		440	215	665	lx : 1.79x10 ⁴ mm ⁴ ly : 2.55x10 ⁴ mm ⁴	8 pcs	100 Bag	800 pcs	
	ASQ2812C		413	202	591	lx : 1.82x10 ⁴ mm ⁴ ly : 2.20x10 ⁴ mm ⁴	8 pcs	100 Bag	800 pcs	
	ASQ2812D		412	202	555	lx : 1.95x10 ⁴ mm ⁴ ly : 1.95x10 ⁴ mm ⁴	8 pcs	100 Bag	800 pcs	
	ASQ2812E		291	150	523	lx : 1.79x10 ⁴ mm ⁴ ly : 1.41x10 ⁴ mm ⁴	8 pcs	100 Bag	800 pcs	
	ASQ2812F		413	204	646	lx : 2.11x10 ⁴ mm ⁴ ly : 3.21x10 ⁴ mm ⁴	4 pcs	110 Bag	440 pcs	
40X40	ASJ4040A		X→	810	420	1,195	lx : 6.85x10 ⁴ mm ⁴ ly : 6.85x10 ⁴ mm ⁴	4 pcs	110 Bag	440 pcs
			Y↓	750	410					
	ASJ4040B		X→	670	420	1,211	lx : 6.89x10 ⁴ mm ⁴ ly : 6.89x10 ⁴ mm ⁴	4 pcs	110 Bag	440 pcs
			Y↓	680	370					
	ASJ4040C		X→	840	440	1,200	lx : 7.73x10 ⁴ mm ⁴ ly : 7.51x10 ⁴ mm ⁴	4 pcs	110 Bag	440 pcs
			Y↓	820	430					
	ASJ4040D		X→	870	440	1,175	lx : 7.72x10 ⁴ mm ⁴ ly : 7.72x10 ⁴ mm ⁴	4 pcs	110 Bag	440 pcs
			Y↓							
	ASJ4040E		X→	650	380	1,145	lx : 6.08x10 ⁴ mm ⁴ ly : 6.08x10 ⁴ mm ⁴	4 pcs	110 Bag	440 pcs
			Y↓	600	330					
ASJ4040R		X→	730	350	1,126	lx : 5.04x10 ⁴ mm ⁴ ly : 6.90x10 ⁴ mm ⁴	4 pcs	110 Bag	440 pcs	
		Y↓	710	350						
ASM4040C		X→	980	490	1,292	lx : 7.56x10 ⁴ mm ⁴ ly : 7.70x10 ⁴ mm ⁴	4 pcs	110 Bag	440 pcs	
		Y↓	900	460						
ASM4040R		X→	750	380	1,169	lx : 6.00x10 ⁴ mm ⁴ ly : 6.99x10 ⁴ mm ⁴	4 pcs	110 Bag	440 pcs	
		Y↓	820	420						
AST4040A		X→	750	400	1,190	lx : 7.13x10 ⁴ mm ⁴ ly : 7.13x10 ⁴ mm ⁴	4 pcs	110 Bag	440 pcs	
		Y↓	850	440						
AST4040D		X→	970	470	1,264	lx : 7.67x10 ⁴ mm ⁴ ly : 7.67x10 ⁴ mm ⁴	4 pcs	110 Bag	440 pcs	
			Y↓							

TECHNICAL SPECIFICATIONS ALUMINUM RACKING SYSTEM

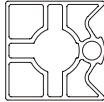
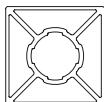
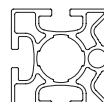
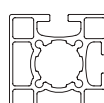
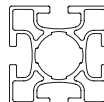
External Size	Part No.	TYPE		Concentrated Load (kgf)		Weight (g/m)	Second Section Moment	4M Packing quantity		
				L=500mm	L=1000mm			pcs/Bag	Bag/Pallet	pcs/Pallet
45X45	ASJ4545A		X→	940	500	1,320	lx : 9.10x10 ⁴ mm ⁴ ly : 9.10x10 ⁴ mm ⁴	4 pcs	90 Bag	360 pcs
			Y↓	940	530					
	ASJ4545C		X→	1000	530	1,412	lx : 11.37x10 ⁴ mm ⁴ ly : 10.59x10 ⁴ mm ⁴	4 pcs	90 Bag	360 pcs
			Y↓	1030	540					
	ASJ4545D		X→	1130	590	1,495	lx : 12.42x10 ⁴ mm ⁴ ly : 12.42x10 ⁴ mm ⁴	4 pcs	90 Bag	360 pcs
			Y↓							
	ASM4545C		X→	1170	640	1,595	lx : 12.35x10 ⁴ mm ⁴ ly : 11.69x10 ⁴ mm ⁴	4 pcs	90 Bag	360 pcs
			Y↓	1050	620					
	AST4545A		X→	1300	660	1,513	lx : 11.41x10 ⁴ mm ⁴ ly : 11.41x10 ⁴ mm ⁴	4 pcs	90 Bag	360 pcs
			Y↓	1350	680					
AST4545D		X→	1220	670	1,607	lx : 12.47x10 ⁴ mm ⁴ ly : 12.47x10 ⁴ mm ⁴	4 pcs	90 Bag	360 pcs	
		Y↓								

ELF PLATE (MANUAL FOR LP2800)

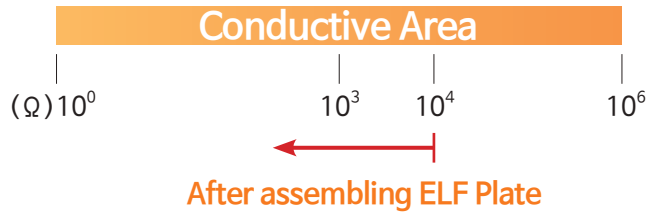
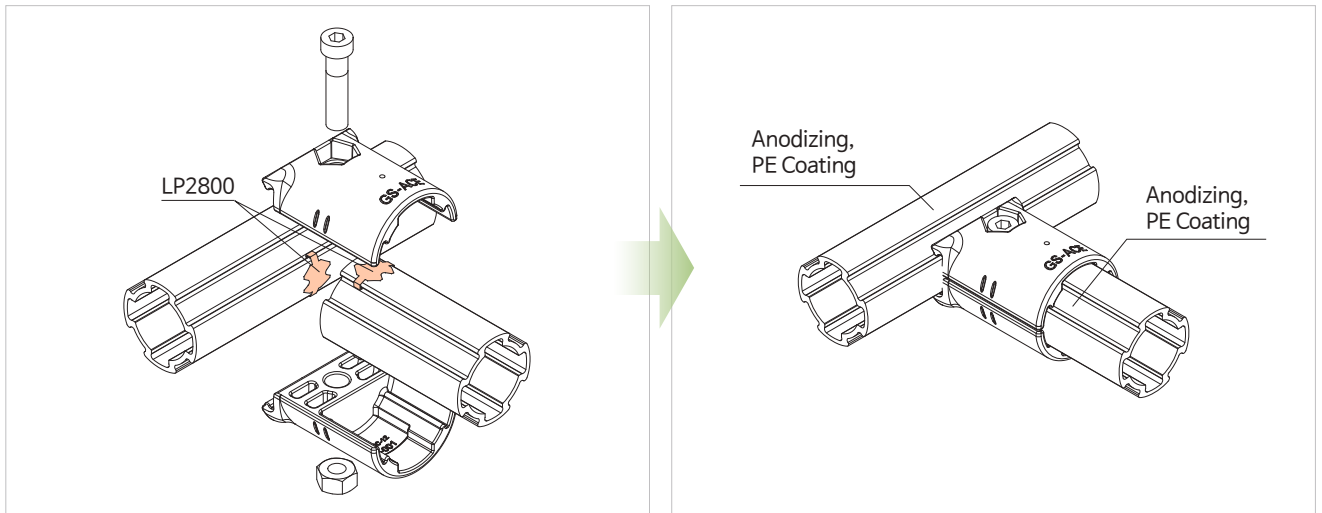

- ※ If conductivity is needed, ELF Plate should be assembled with all kind of AL Joint
- ※ ELF Plate : LP2800

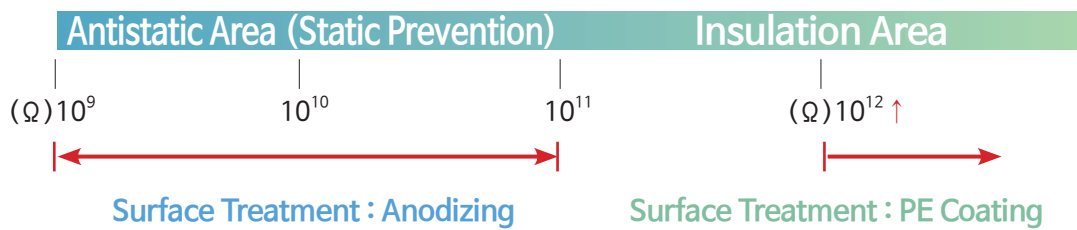
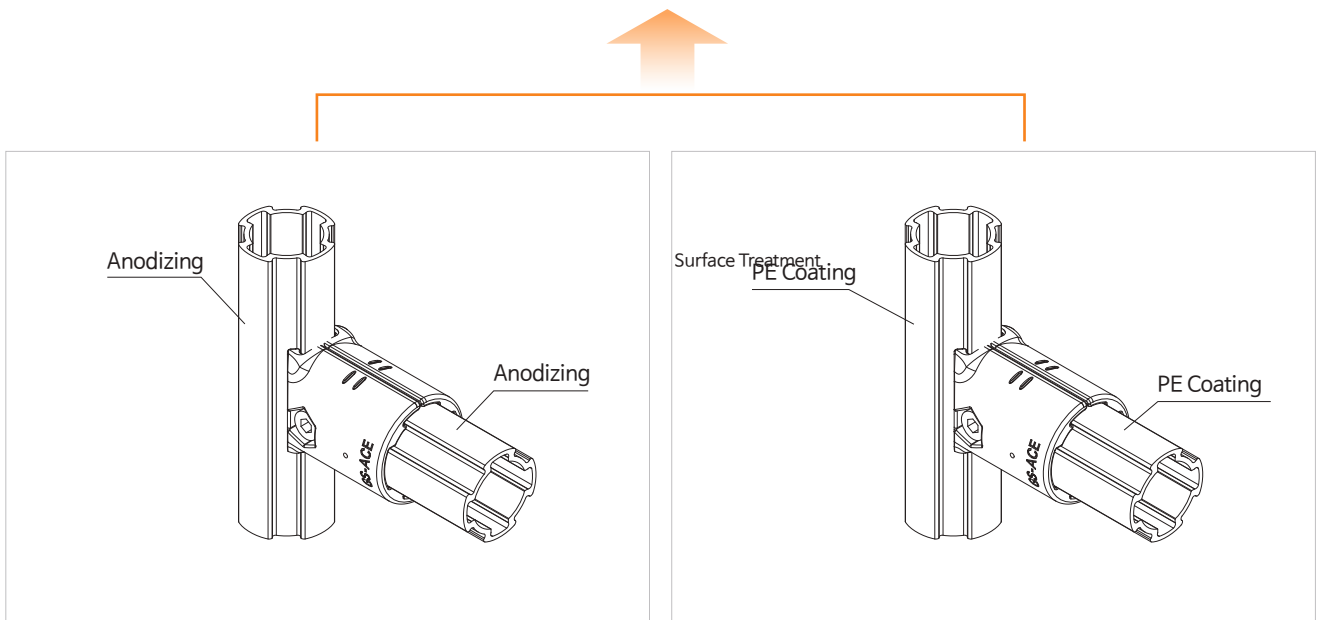

TECHNICAL SPECIFICATIONS ALUMINUM RACKING SYSTEM

JOINT HOLDING FORCE & MOMENT

AA-001

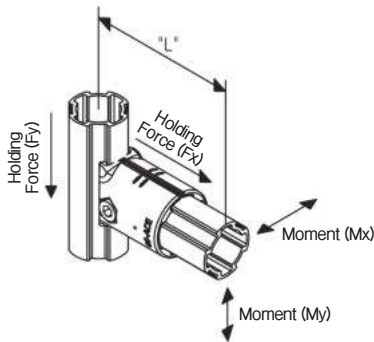

Holding Force (kgf)	Fx	80
	Fy	80
Moment (kgf) (L=110mm)	Mx	60
	My	120

AA-001C

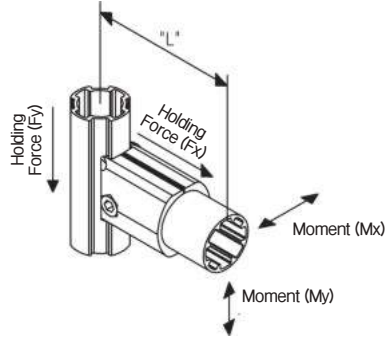

Holding Force (kgf)	Fx	80
	Fy	80
Moment (kgf) (L=110mm)	Mx	50
	My	100

AA-002

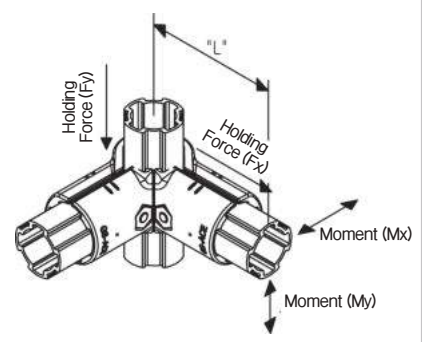

Holding Force (kgf)	Fx	80
	Fy	200
Moment (kgf) (L=110mm)	Mx	60
	My	120

AA-003

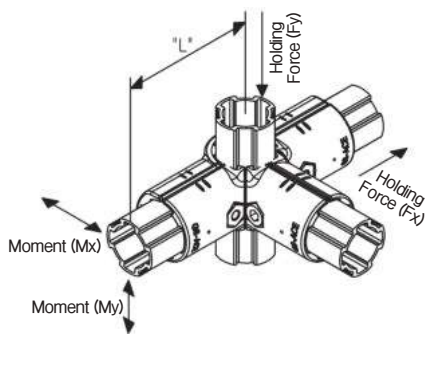

Holding Force (kgf)	Fx	80
	Fy	80
Moment (kgf) (L=110mm)	Mx	60
	My	120

AA-004

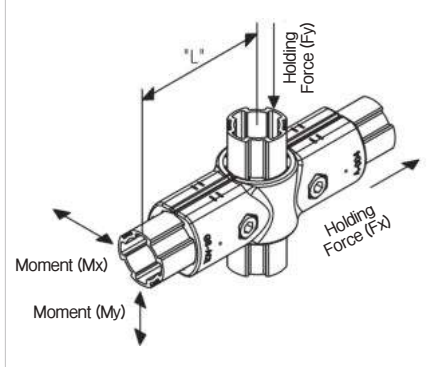

Holding Force (kgf)	Fx	80
	Fy	80
Moment (kgf) (L=110mm)	Mx	60
	My	120

AA-007F / AA-007R

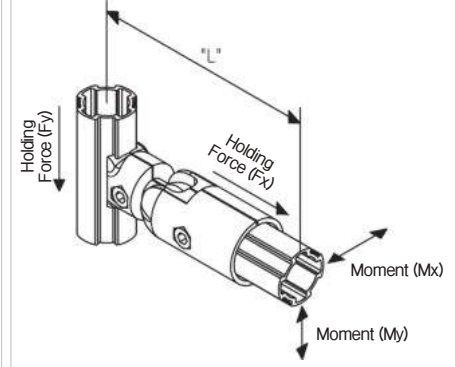

Holding Force (kgf)	Fx	80
	Fy	80
Moment (kgf) (L=110mm)	My	50

AA-027F/AA-027M

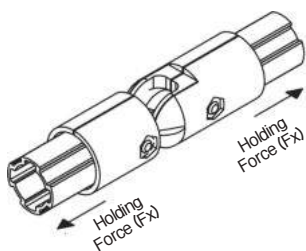

Holding Force (kgf)	Fx	80
---------------------	----	----

AA-009

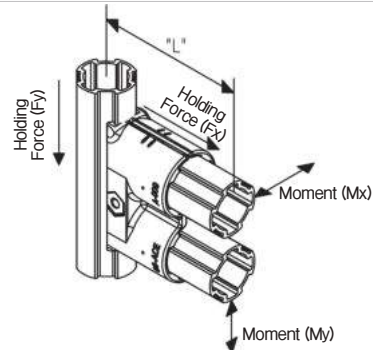

Holding Force (kgf)	Fx	80
	Fy	80
Moment (kgf) (L=110mm)	Mx	250
	My	500

AA-013

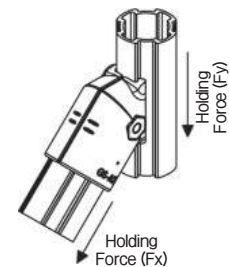

Holding Force (kgf)	Fx	80
	Fy	80

TECHNICAL SPECIFICATIONS ALUMINUM RACKING SYSTEM

JOINT HOLDING FORCE & MOMENT

AA-021

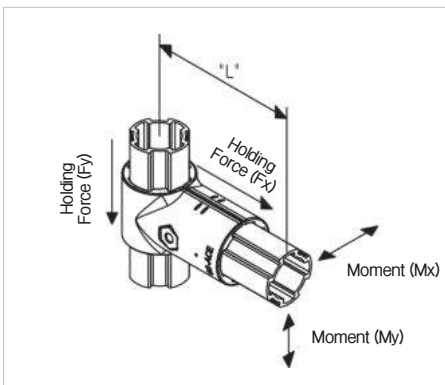

Holding Force (kgf)	Fx	80
	Fy	200
Moment (kgf) (L=110mm)	Mx	60
	My	120

AA-023

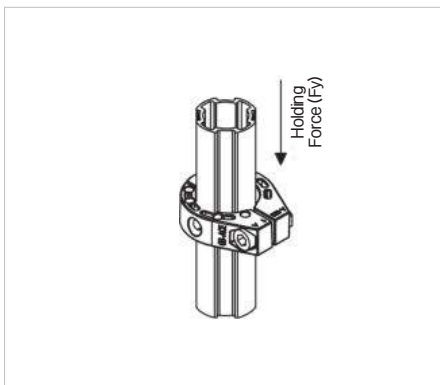

Holding Force (kgf)	Fy	80
---------------------	----	----

AA-028

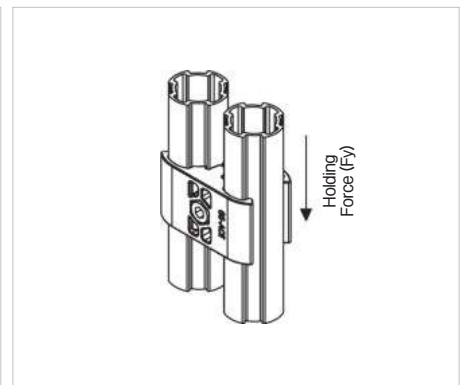

Holding Force (kgf)	Fy	80
---------------------	----	----

AA-090

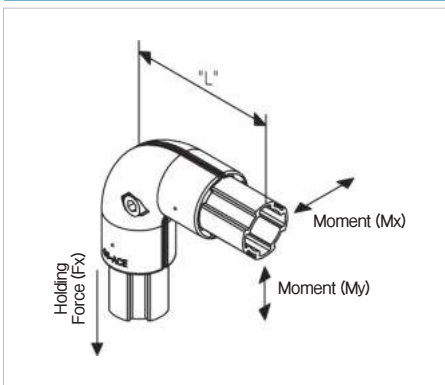

Holding Force (kgf)	Fx	80
	Fy	80
Moment (kgf) (L=110mm)	Mx	50
	My	100

AA-101

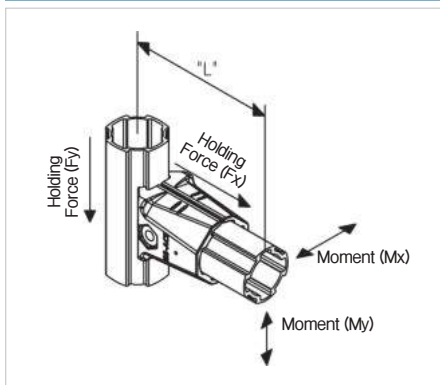

Holding Force (kgf)	Fx	80
	Fy	80
Moment (kgf) (L=110mm)	Mx	50
	My	100

AA-104

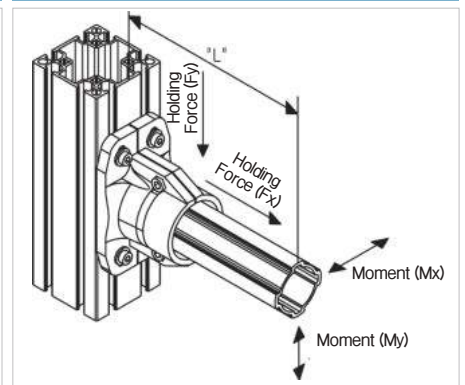

Holding Force (kgf)	Fx	100
	Fy	100
Moment (kgf) (L=110mm)	Mx	300
	My	500

AA-201

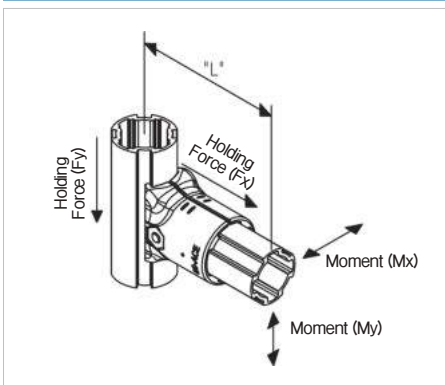

Holding Force (kgf)	Fx	80
	Fy	80
Moment (kgf) (L=110mm)	Mx	60
	My	120

AA-301

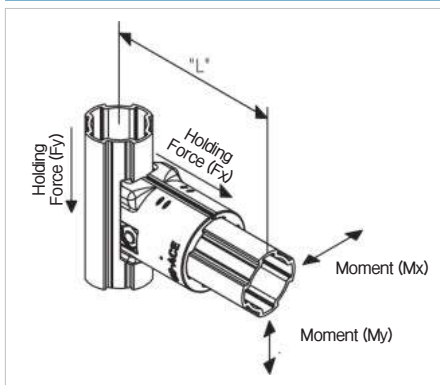

Holding Force (kgf)	Fx	80
	Fy	200
Moment (kgf) (L=110mm)	Mx	60
	My	120

AA-401

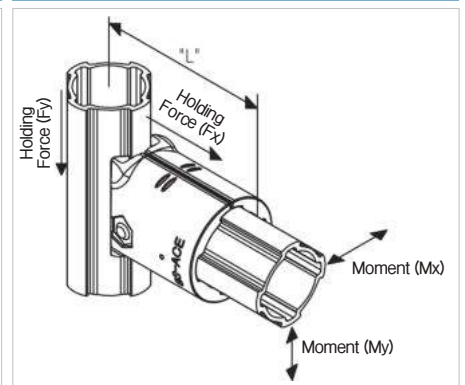

Holding Force (kgf)	Fx	100
	Fy	200
Moment (kgf) (L=110mm)	Mx	80
	My	200

TECHNICAL SPECIFICATIONS ALUMINUM RACKING SYSTEM

JOINT HOLDING FORCE & MOMENT

AA-401W

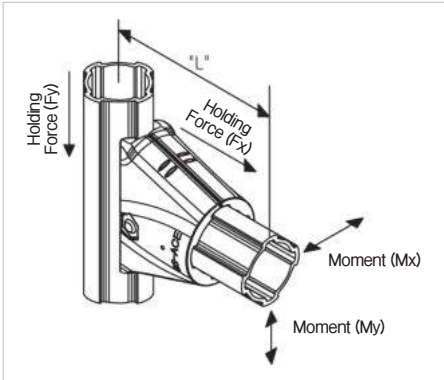

Holding Force (kgf)	Fx	150
	Fy	400
Moment (kgf) (L=110mm)	Mx	200
	My	600

AA-407F

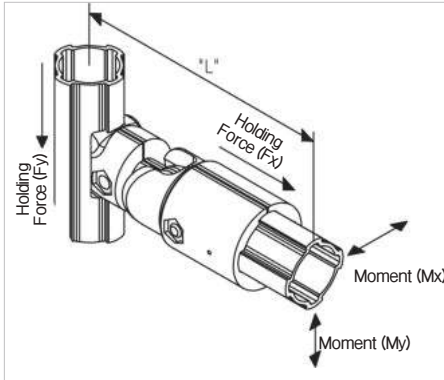

Holding Force (kgf)	Fx	100
	Fy	200
Moment (kgf) (L=110mm)	Mx	80

AA-413

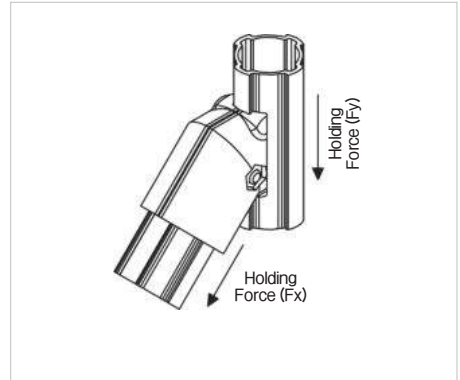

Holding Force (kgf)	Fx	100
	Fy	200

AA-421

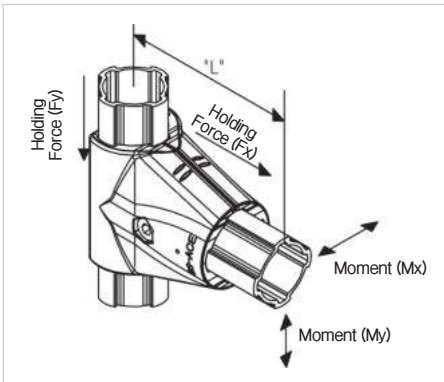

Holding Force (kgf)	Fx	150
	Fy	400
Moment (kgf) (L=110mm)	Mx	200
	My	600

AA-490

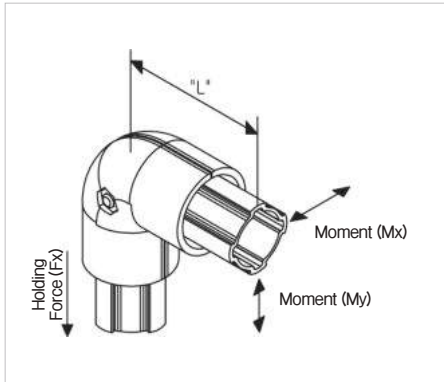

Holding Force (kgf)	Fx	100
	Mx	200
Moment (kgf) (L=110mm)	My	400

TECHNICAL

JOINT HOLDING FORCE & MOMENT

BA-001

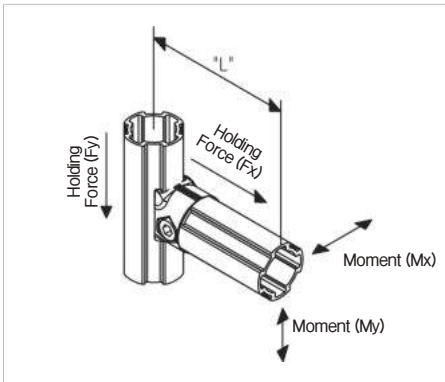

Holding Force (kgf)	Fx	80
	Fy	80
Moment (kgf) (L=110mm)	Mx	40
	My	80

BA-001C

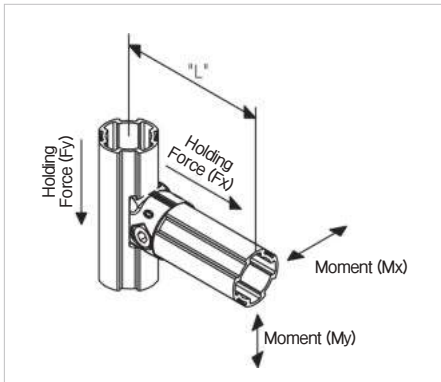

Holding Force (kgf)	Fx	80
	Fy	80
Moment (kgf) (L=110mm)	Mx	40
	My	80

BA-001H

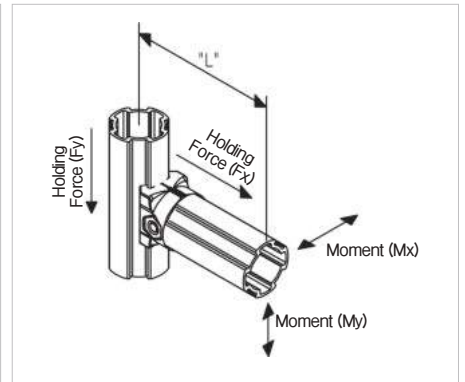

Holding Force (kgf)	Fx	100
	Fy	100
Moment (kgf) (L=110mm)	Mx	40
	My	80

BA-006

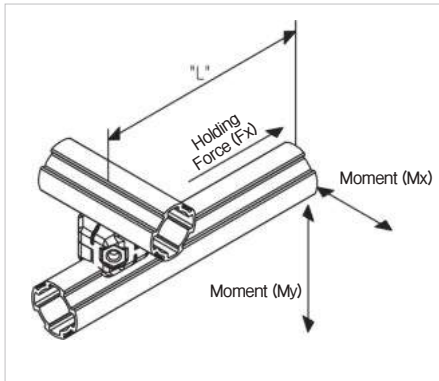

Holding Force (kgf)	Fx	80
	Mx	90
Moment (kgf) (L=110mm)	My	60

BA-007F / BA-007R

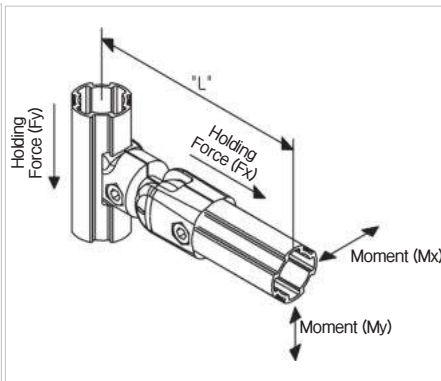

Holding Force (kgf)	Fx1	50
	Fy2	80
Moment (kgf) (L=110mm)	Mx	50

BA-008

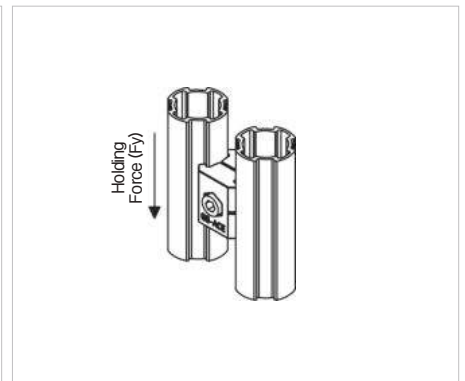

Holding Force (kgf)	Fy	80
---------------------	----	----

BA-011

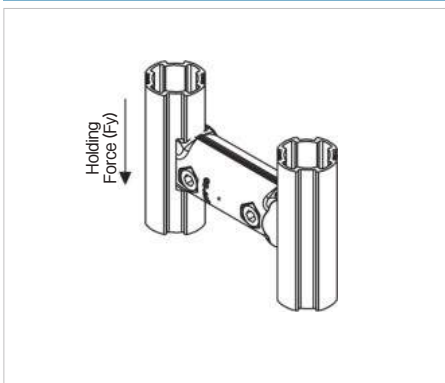

Holding Force (kgf)	Fy	80
---------------------	----	----

BA-013

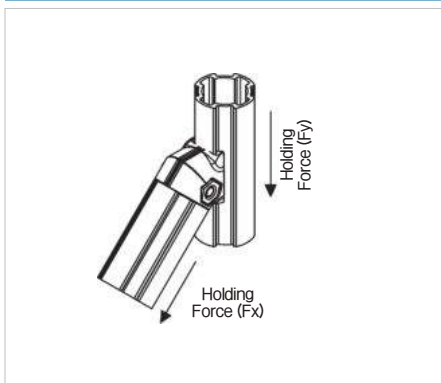

Holding Force (kgf)	Fx	80
	Fy	80

BA-027F / BA-027M

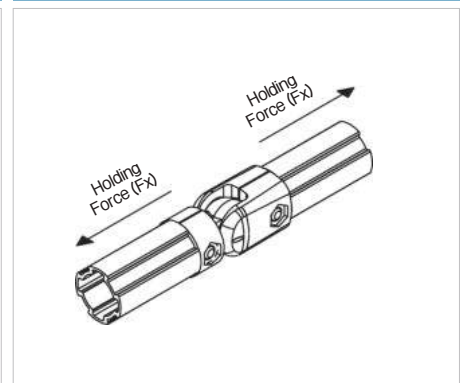

Holding Force (kgf)	Fx	50
---------------------	----	----

TECHNICAL SPECIFICATIONS ALUMINUM RACKING SYSTEM

JOINT HOLDING FORCE & MOMENT

BA-044B

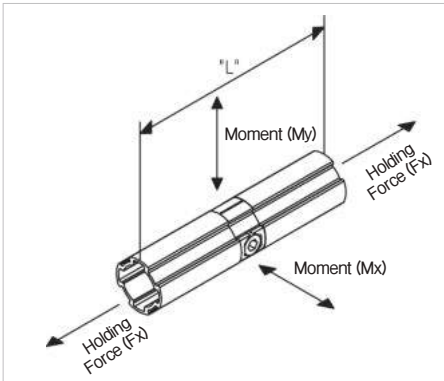

Holding Force (kgf)	Fx	80
Moment (kgf) (L=500mm)	Mx	50
	My	20
Moment (kgf) (L=110mm)	Mx	30
	My	10

BA-045

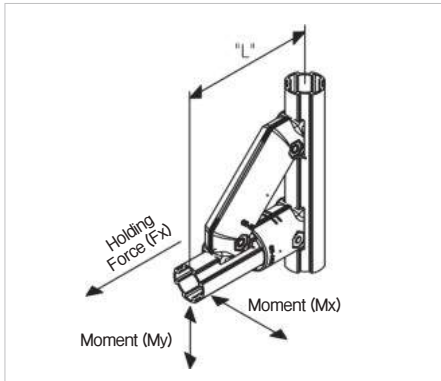

Holding Force (kgf)	Fx	500
Moment (kgf) (L=110mm)	Mx	100
	My	200

BA-090

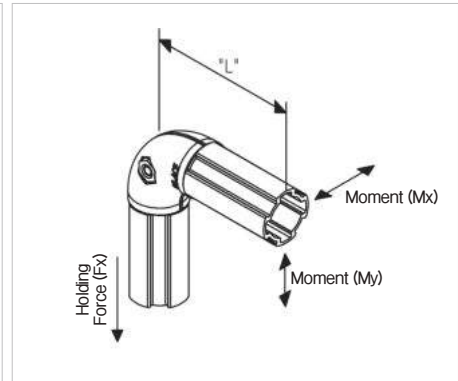

Holding Force (kgf)	Fx	80
	Fy	80
Moment (kgf) (L=110mm)	Mx	50
	My	100

BA-091

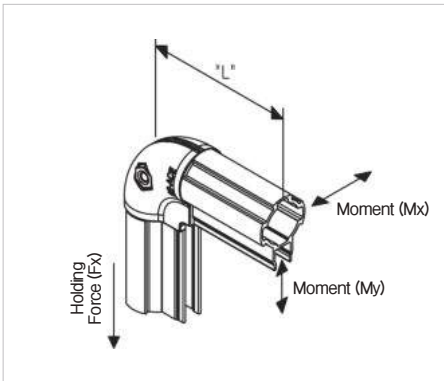

Holding Force (kgf)	Fx	80
	Fy	80
Moment (kgf) (L=110mm)	Mx	50
	My	100

BA-101

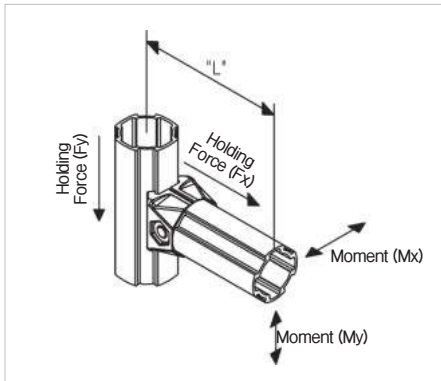

Holding Force (kgf)	Fx	80
	Fy	80
Moment (kgf) (L=110mm)	Mx	40
	My	80

BA-145

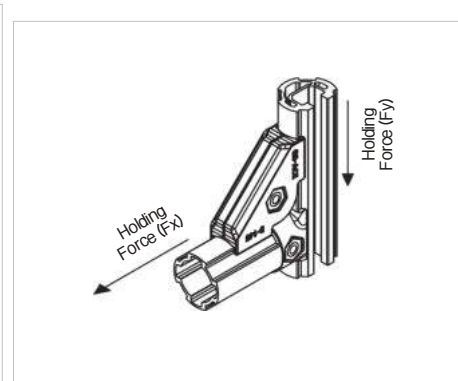

Holding Force (kgf)	Fx	40
	Fy	40

BA-206

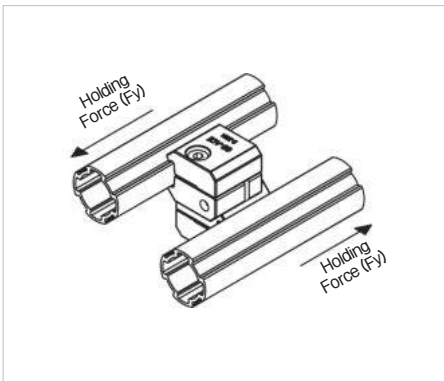

Holding Force (kgf)	Fy	80
---------------------	----	----

BA-301

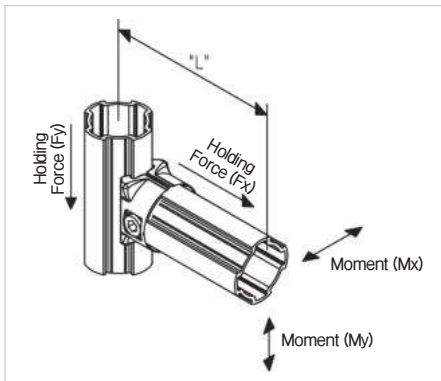

Holding Force (kgf)	Fx	100
	Fy	150
Moment (kgf) (L=110mm)	Mx	50
	My	120

BA-401

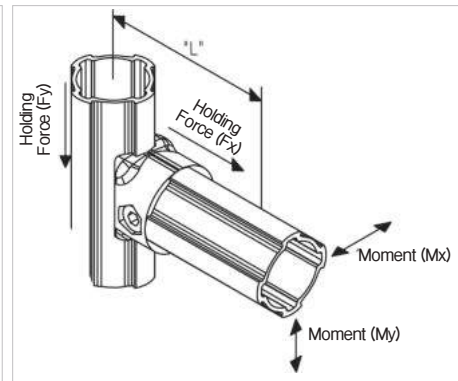

Holding Force (kgf)	Fx	100
	Fy	200
Moment (kgf) (L=110mm)	Mx	80
	My	150

TECHNICAL SPECIFICATIONS ALUMINUM RACKING SYSTEM

JOINT HOLDING FORCE & MOMENT

BA-407F

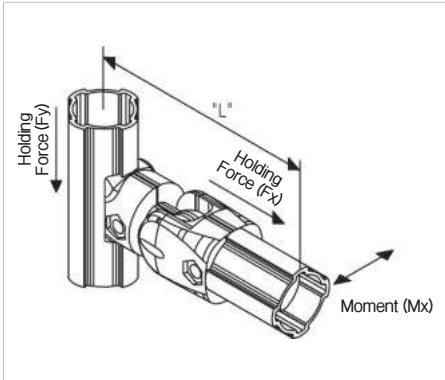

Holding Force (kgf)	Fx1	100
	Fy2	200
Moment (kgf) (L=110mm)	Mx	80

BA-411

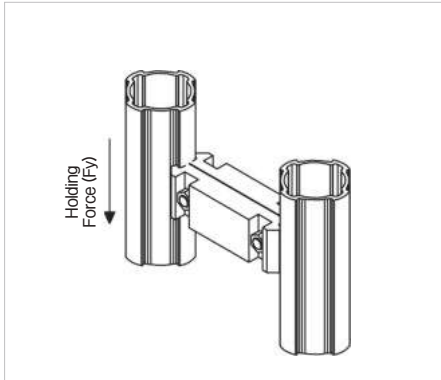

Holding Force (kgf)	Fx	80
---------------------	----	----

BA-427F

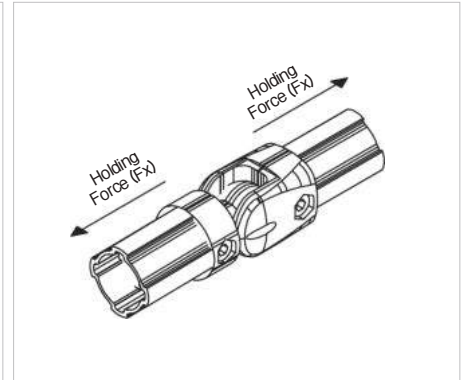

Holding Force (kgf)	Fx	100
---------------------	----	-----

BA-444

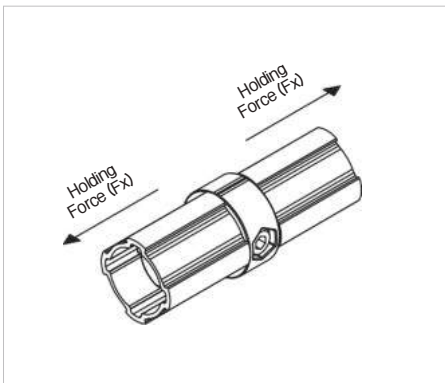

Holding Force (kgf)	Fx	100
---------------------	----	-----

BA-445

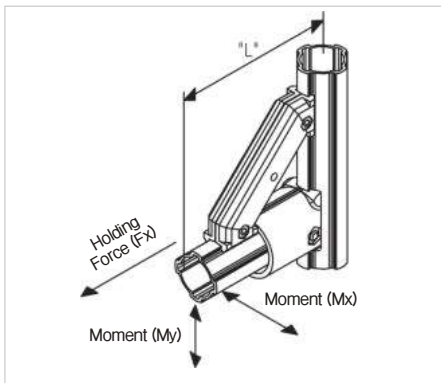

Holding Force (kgf)	Fx	500
	Mx	100
Moment (kgf) (L=110mm)	My	200

BA-490

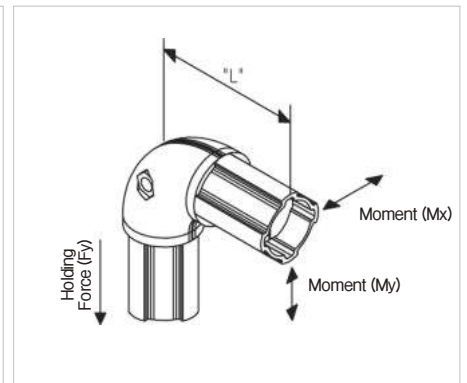

Holding Force (kgf)	Fx	100
	Mx	100
Moment (kgf) (L=110mm)	My	200

CA-001

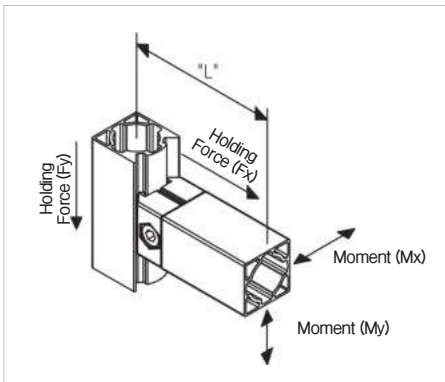

Holding Force (kgf)	Fx	100
	Fy	200
Moment (kgf) (L=110mm)	Mx	50
	My	100

DA-001

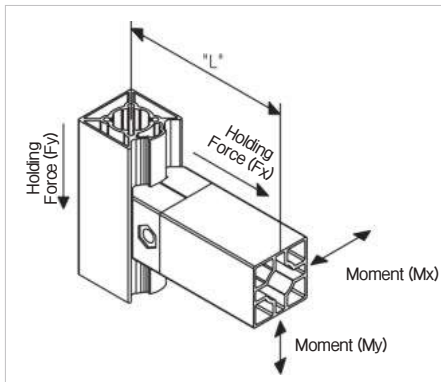

Holding Force (kgf)	Fx	100
	Fy	200
Moment (kgf) (L=110mm)	Mx	100
	My	120

EA-001

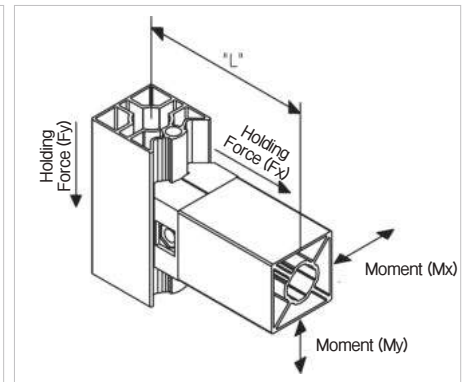

Holding Force (kgf)	Fx	100
	Fy	200
Moment (kgf) (L=110mm)	Mx	100
	My	120

TECHNICAL

TECHNICAL SPECIFICATIONS ALUMINUM RACKING SYSTEM

JOINT HOLDING FORCE & MOMENT

BA2800A/B

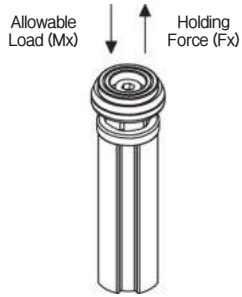

Holding Force (kgf)	Fx	80
Allowable Load (kgf)	Mx	1,000

BA280LA/B/D/E

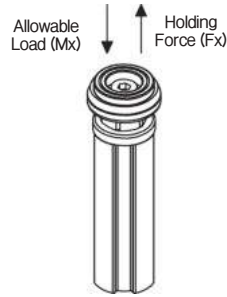

Holding Force (kgf)	Fx	80
Allowable Load (kgf)	Mx	1,000

BP2800H

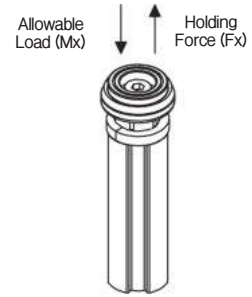

Holding Force (kgf)	Fx	50
Allowable Load (kgf)	Mx	300

BA2818E

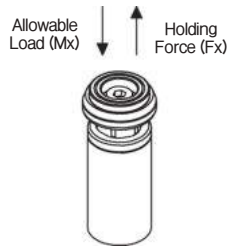

Holding Force (kgf)	Fx	80
Allowable Load (kgf)	Mx	1,000

BA3300A/B/D

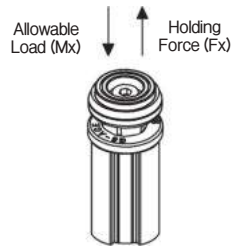

Holding Force (kgf)	Fx	80
Allowable Load (kgf)	Mx	1,000

BA4300A/B/D

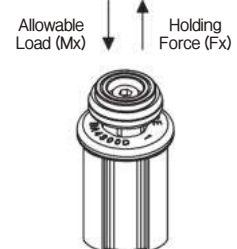

Holding Force (kgf)	Fx	80
Allowable Load (kgf)	Mx	1,000

BP4300H

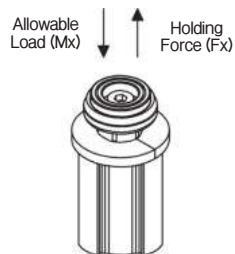

Holding Force (kgf)	Fx	80
Allowable Load (kgf)	Mx	700

BA4040A/B

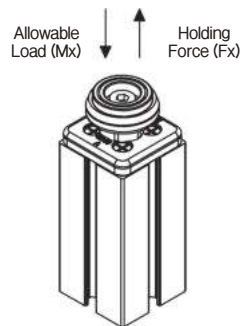

Holding Force (kgf)	Fx	1,200
Allowable Load (kgf)	Mx	1,000

BA4545A/B

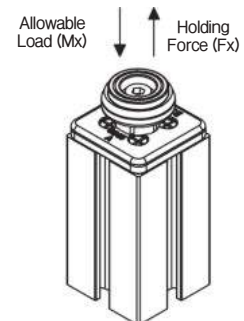

Holding Force (kgf)	Fx	1,200
Allowable Load (kgf)	Mx	1,000

TECHNICAL SPECIFICATIONS ALUMINUM RACKING SYSTEM

JOINT HOLDING FORCE & MOMENT

ABS-0530

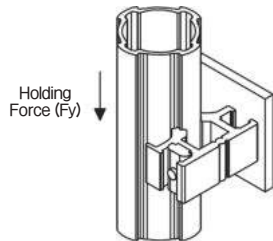

Holding Force (kgf)	Fy	50
---------------------	----	----

ABS-4320A/C/D/E

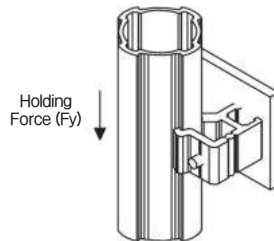

Holding Force (kgf)	Fy	50
---------------------	----	----

ABS-620

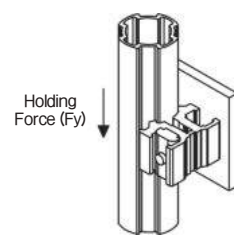

Holding Force (kgf)	Fy	50
---------------------	----	----

ACHA-6040A

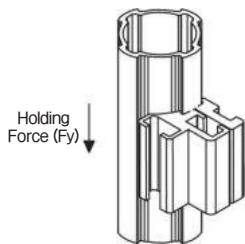

Holding Force (kgf)	Fy	50
---------------------	----	----

ACPA-H6026A

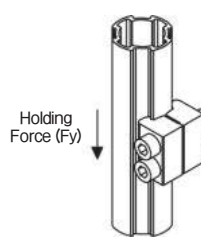

Holding Force (kgf)	Fy	200
---------------------	----	-----

ACPA-V6026A

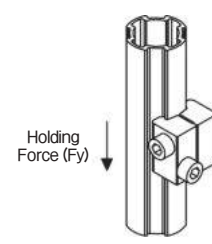

Holding Force (kgf)	Fy	100
---------------------	----	-----

ACA-309A

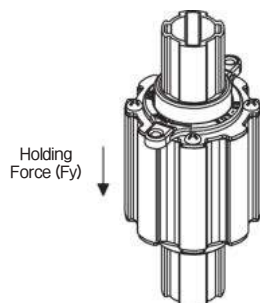

Holding Force (kgf)	Fy	100
---------------------	----	-----

ACBA-B28A/B

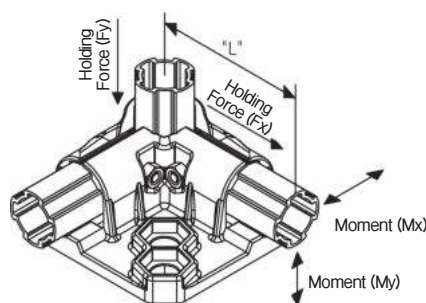

Holding Force (kgf)	Fx	80
	Fy	200
Moment (kgf) (L=110mm)	Mx	60
	My	120

ACY-318A/B

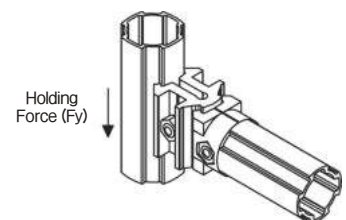

Holding Force (kgf)	Fy	40
---------------------	----	----

TECHNICAL SPECIFICATIONS ALUMINUM RACKING SYSTEM

JOINT HOLDING FORCE & MOMENT

ACY-06A

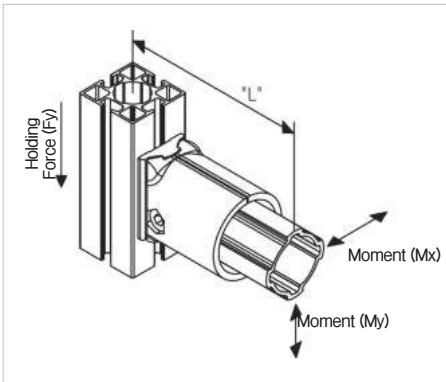

Holding Force (kgf)	Fx	80
Moment (kgf) (L=110mm)	Mx	60
	My	120

ACY-07A

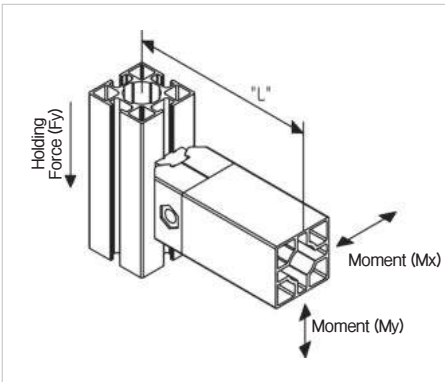

Holding Force (kgf)	Fx	80
Moment (kgf) (L=110mm)	Mx	60
	My	120

ACY-08A

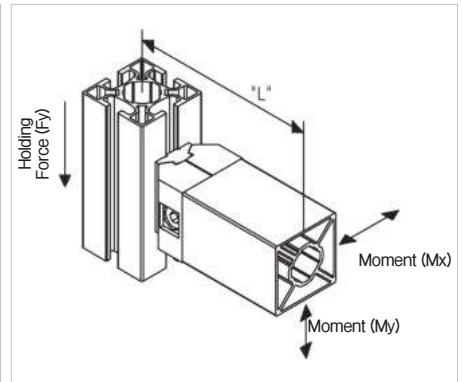

Holding Force (kgf)	Fx	80
Moment (kgf) (L=110mm)	Mx	60
	My	120

ACY-N304

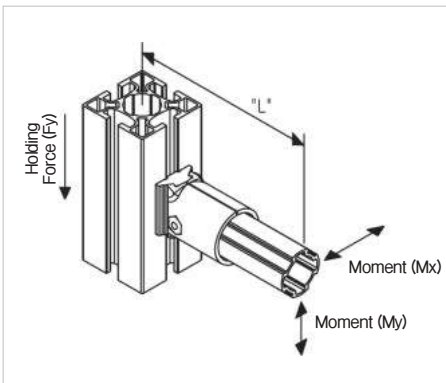

Holding Force (kgf)	Fx	80
Moment (kgf) (L=110mm)	Mx	60
	My	100

ACY-N307

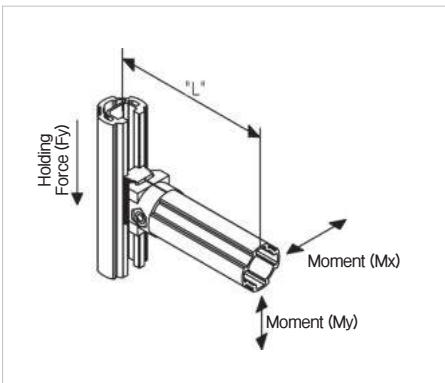

Holding Force (kgf)	Fx	80
Moment (kgf) (L=110mm)	Mx	40
	My	50

ADT-5H

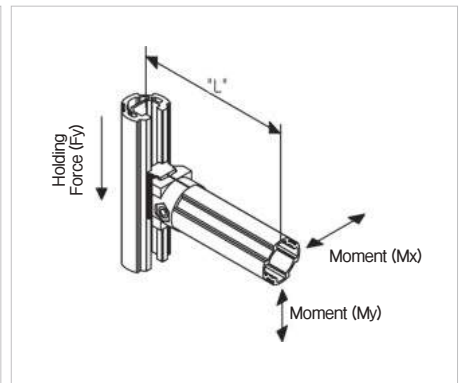

Holding Force (kgf)	Fx	50
Moment (kgf) (L=110mm)	Mx	40
	My	100

ADT-06/08

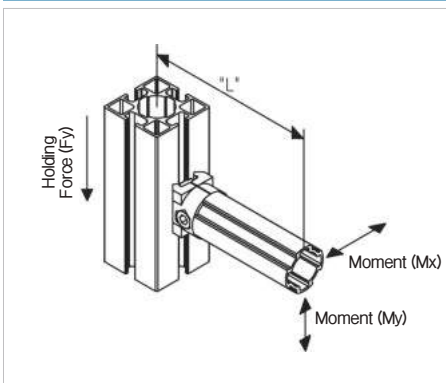

Holding Force (kgf)	Fx	50
Moment (kgf) (L=110mm)	Mx	40
	My	40

ADT-5043A

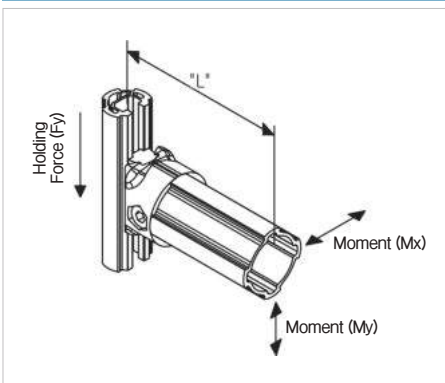

Holding Force (kgf)	Fx	100
Moment (kgf) (L=110mm)	Mx	60
	My	100

AWM-2533A

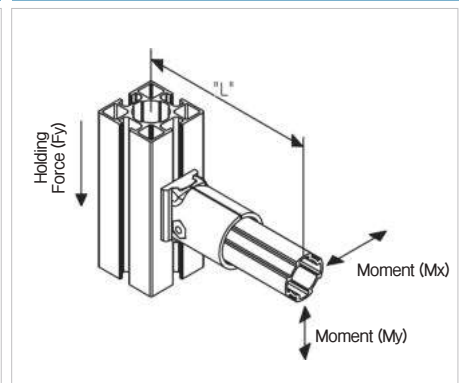

Holding Force (kgf)	Fx	30
Moment (kgf) (L=110mm)	Mx	50
	My	100

TECHNICAL SPECIFICATIONS ROLLER TRACK SYSTEM

JOINT HOLDING FORCE & MOMENT

AFU-28A/C/S

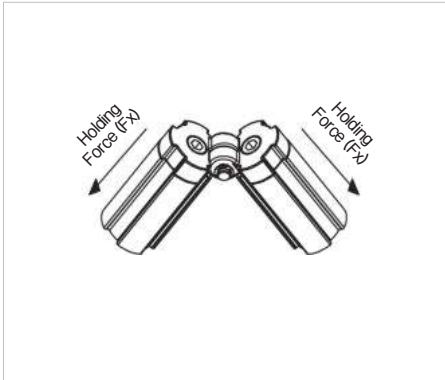

Holding Force (kgf)	F_y	40
---------------------	-------	----

APHA-3027

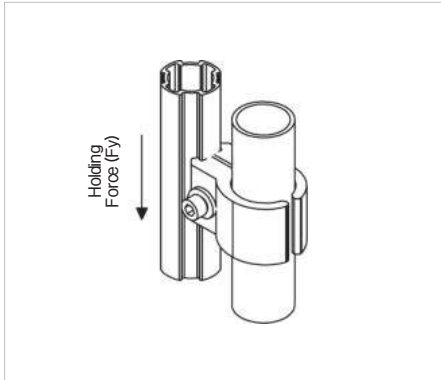

Holding Force (kgf)	F_y (AL Pipe)	80
---------------------	--------------------	----

APHA-633N

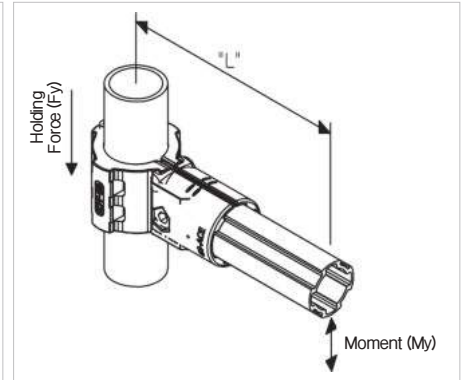

Holding Force (kgf)	F_x (AL Pipe)	30
Moment (kgf) (L=110mm)	M_y	120

B-017A-08

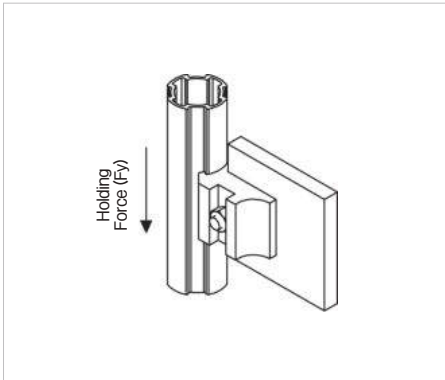

Holding Force (kgf)	F_y	30
---------------------	-------	----

LAD-A

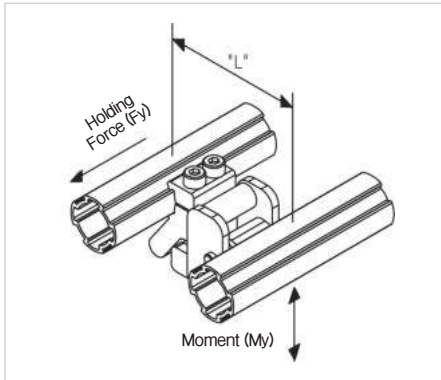

Holding Force (kgf)	F_y	200
Moment (kgf) (L=110mm)	M_y	100

AOS-28A

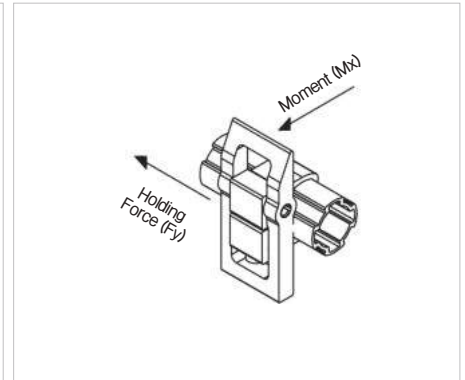

Holding Force (kgf)	F_x	80
Moment (kgf)	M_x	300

TECHNICAL SPECIFICATIONS ROLLER TRACK SYSTEM

BENDING STRENGTH FOR ROLLER TRACK

Unit: Kgf

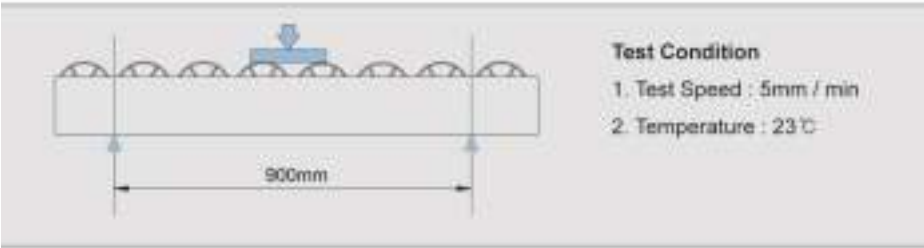

Model	Load
35 Serise	80
40 Serise	150
60 Serise	100
85 Serise	300

COMPRESSION STRENGTH OF WHEEL SUBASSEMBL

Unit: Kgf



Model	Load
35 Serise	100
40 Serise	150
60 Serise	200
85 Serise	300

ANGLE RECOMMENDED FOR CONSISTENT

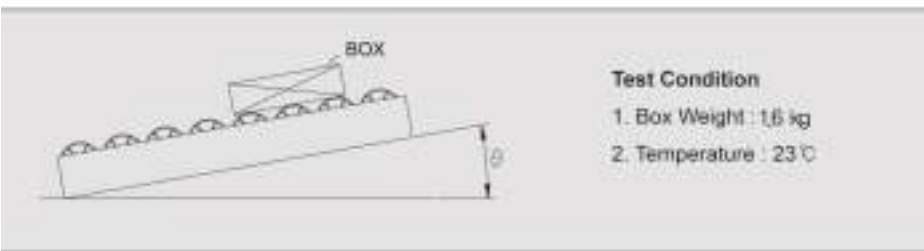

Model	Load
35 Serise	2.5 °
40 Serise	2.0 °
60 Serise	2.5 °
85 Serise	2.5 °

ROLLER TRACK MAXIMUM LOAD(GI-BODY)

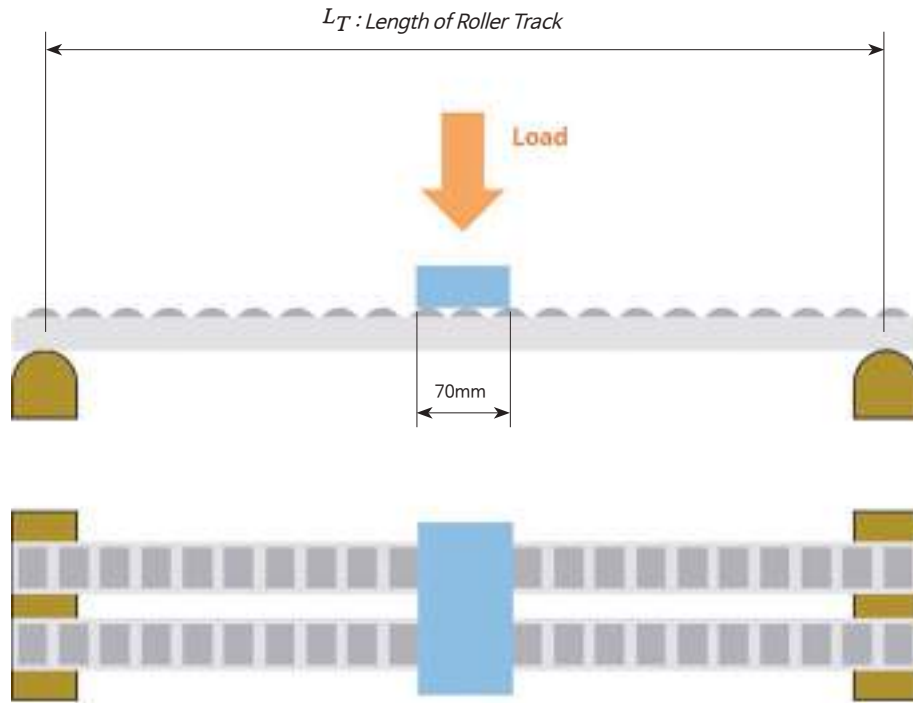

■ 3 mm Deflection allowed condition (for 2 parallel Roller Track)

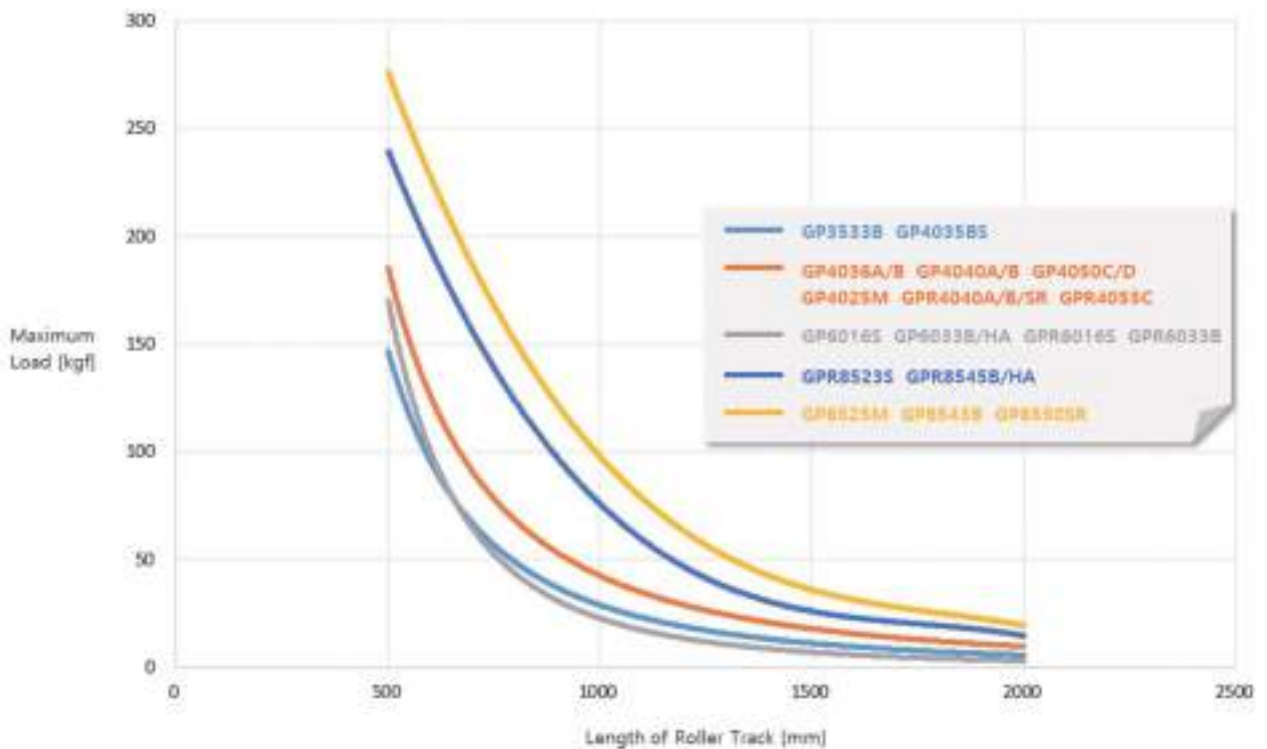

■ 5 mm Deflection allowed condition (for 2 parallel Roller Track)

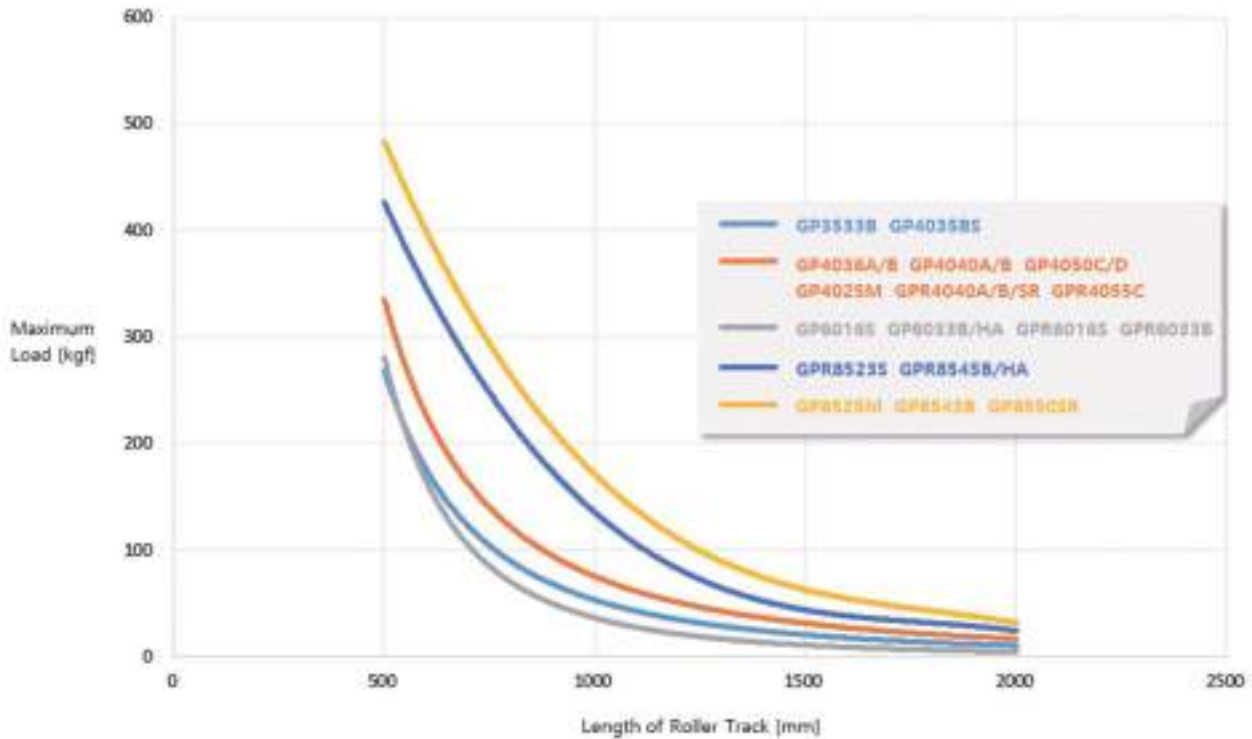

■ 10 mm Deflection allowed condition (for 2 parallel Roller Track)

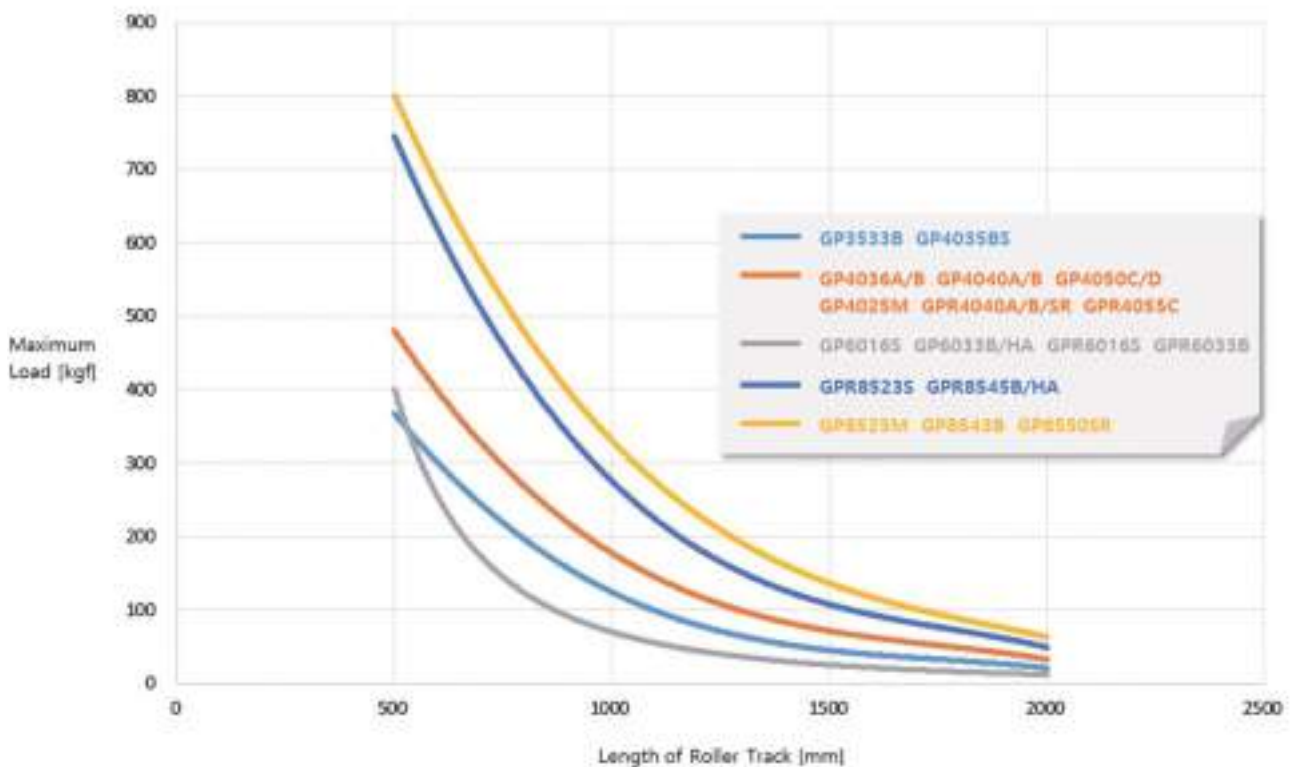

ROLLER TRACK MAXIMUM LOAD(AL-BODY)

■ 3 mm Deflection allowed condition (for 2 parallel Roller Track)

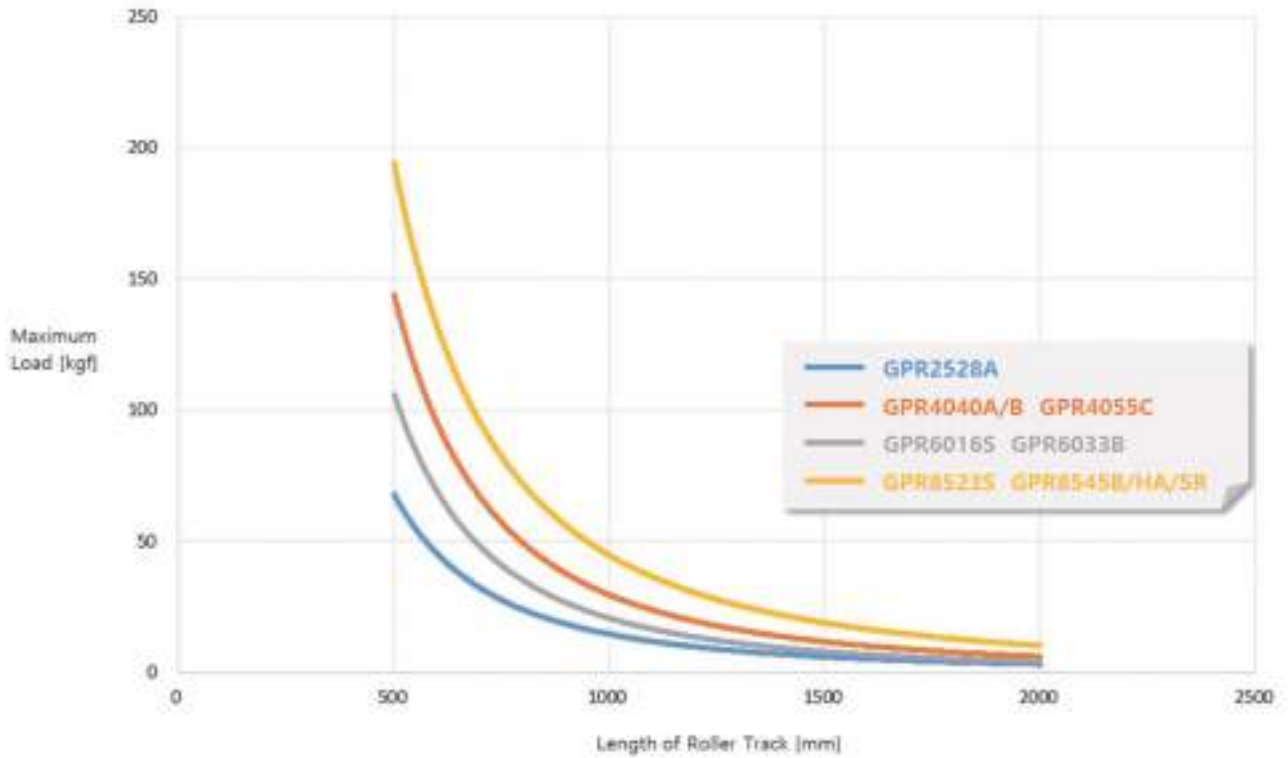

■ 5 mm Deflection allowed condition (for 2 parallel Roller Track)

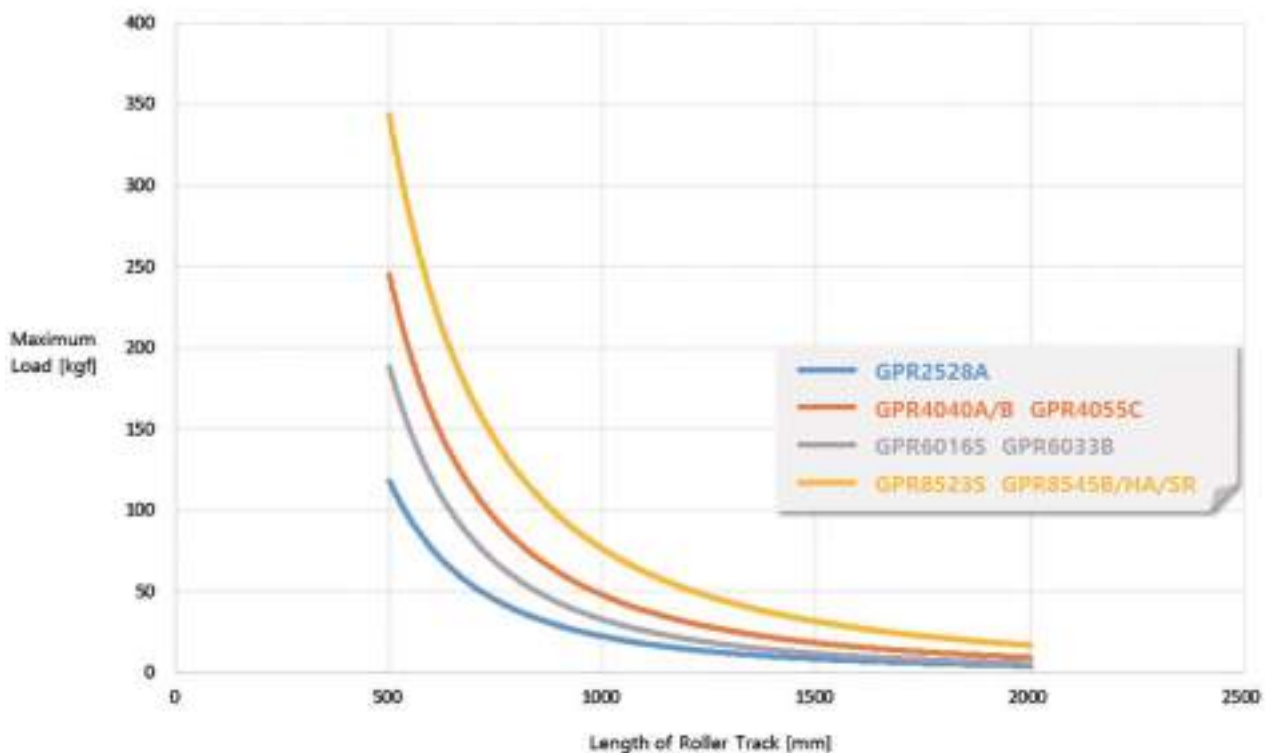

TECHNICAL SPECIFICATIONS

■ 10 mm Deflection allowed condition (for 2 parallel Roller Track)

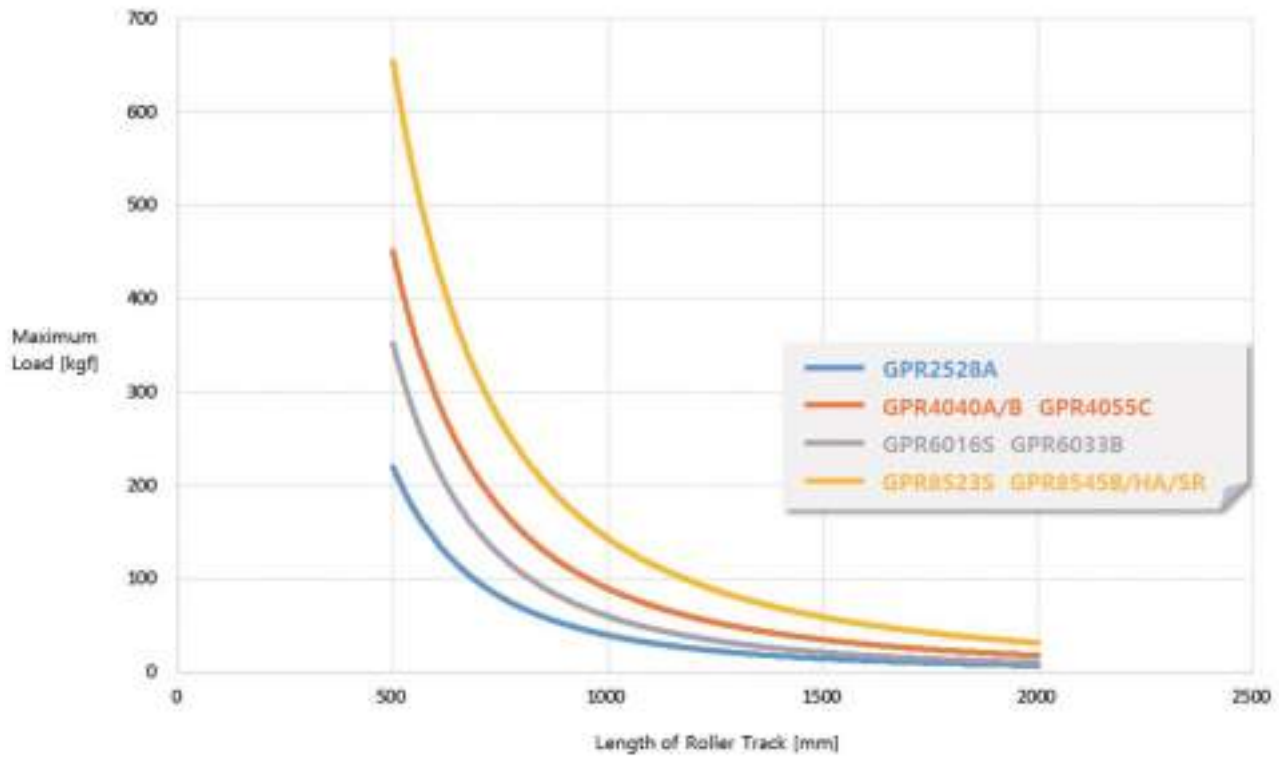

EXAMPLES

EXAMPLES FOR IMPROVEMENT



EXAMPLES

EXAMPLES FOR IMPROVEMENT



EXAMPLES



EXAMPLES EXAMPLES FOR IMPROVEMENT



EXAMPLES

EXAMPLES EXAMPLES FOR SLIDING RACK



EXAMPLES

EXAMPLES EXAMPLES FOR SLIDING RACK



EXAMPLES

EXAMPLES

EXAMPLES FOR SLIDING RACK



EXAMPLES

EXAMPLES

EXAMPLES FOR CART



EXAMPLES

EXAMPLES

EXAMPLES FOR CART



EXAMPLES EXAMPLES FOR CART



EXAMPLES

EXAMPLES

EXAMPLES FOR CART



EXAMPLES

EXAMPLES

EXAMPLES of ALUMINUM RACKING SYSTEM

Logistical Storage Rack



EXAMPLES

EXAMPLES

EXAMPLES of ALUMINUM RACKING SYSTEM

Cart



Stairway & Fence for Safety



EXAMPLES

EXAMPLES of ALUMINUM RACKING SYSTEM

Stairway for Safety



Stairway for Safety



Auxiliary Stage



EXAMPLES

EXAMPLES

EXAMPLES of ALUMINUM RACKING SYSTEM



EXAMPLES

EXAMPLES

EXAMPLES of ALUMINUM RACKING SYSTEM

Fence for Safety



EXAMPLES

EXAMPLES

EXAMPLES of ALUMINUM RACKING SYSTEM

Handrail for Safety



Modern Art Exhibit Hall



※ Became a subject of an exhibit named “GA SEOL (Temporary Installation)”

Prefabricated Fence



Prefabricated Stage



Cart for Cafe



Prefabricated Stage



Temporary Bar



Drone Exhibition Stand



Fence for Construction Site



Roller Skate Trainer



Surfboard Storage Rack



Pigpen



Table & Chair



Water Culture



INDEX

Part No.	Part Name (KR)	Page	Part No.	Part Name (KR)	Page
A			ABS-620	Board Support	65
A-001	Single Tee Joint	56	AC2809A	Thread Insert	214
A-001C	Single Tee Joint (For Round Pipe)	56	AC2809B	Thread Insert	214
A-003	Outer Elbow Joint	56	AC2809N	Aluminum Cap	215
A-004	Straight Joint	56	AC2814A	Thread Insert	214
A-007B	Swivel Joint (Angle Adjust & Fix)	57	AC2814B	Thread Insert	214
A-007C	Swivel Joint (Angle Adjustable)	57	AC2814N	Aluminum Cap	215
A-007D	Swivel Joint (Rotation, Angle Adjustable)	57	ACA-2060A	Link Guide Unit	71
A-009	Double Tee Joint	58	ACA-2080A	Link Guide Unit	71
A-013L	45 ° Joint	58	ACA-308A	Decelerator	128
A-013R	45 ° Joint	58	ACA-308B	Decelerator	128
A-021	Single Tee Joint	58	ACA-308C	Decelerator	128
A-023	Stop Joint	58	ACA-309A	One Way Clutch	68
A-028	Parallel Joint	59	ACA-315A	Joint Coupling Clamp	70
A-090	90 ° Elbow Joint	59	ACA-319A	Hinge Unit	76
A-101	Single Tee Joint	59	ACA-4060A	Link Guide Unit	71
A-104	Profile Joint	92	ACA-4080A	Link Guide Unit	71
A-201	Single Tee Joint	59	ACBA-B28A	AL Corner Base Assembly	72
A28-301A	Gas Spring Bracket	65	ACBA-B28B	AL Corner Base Assembly	72
A28-301B	Gas Spring Bracket	65	ACB-B28A	AL Corner Base	72
A28-A301	Gas Spring Bracket Assembly	65	ACB-B28B	AL Corner Base	72
A28-N302	AL Board Support (Outside)	65	ACD-B	Cable Duct	72
A28-N303	AL Board Support (Inside)	65	ACF2812	Φ28 Flat Pipe	55
A-301	Single Tee Joint	86	ACH-6040A-L	AL Component Holder	94
A-401	Single Tee Joint	88	ACH-6040A-R	AL Component Holder	94
A-401W	Single Tee Joint (Heavy Duty)	88	ACHA-6040A	AL Component Holder Assembly	94
A-407B	Swivel Joint (Angle Adjust & Fix)	88	ACM-500	AL Caster Mount	72
A-413L	45 ° Joint	88	ACM-500-S	AL Caster Mount (For Aid)	72
A-413R	45 ° Joint	88	ACM-600	AL Caster Mount	95
A-421	Single Tee Joint (Heavy Duty)	89	ACPA-H6026A	AL Connection Piece Assembly	73
A43-N301	Aluminum Stanchion Mount	92	ACPA-V6026A	AL Connection Piece Assembly	73
A43-N303	Board Support for Φ43	92	ACP-H6026A-L	AL Connection Piece	73
A-490	90 ° Elbow Joint	89	ACP-H6026A-R	AL Connection Piece	73
AA-001	Single Tee Joint Assembly	56	ACPS-H6026A	Spring Shaft Assembly	73
AA-001C	Single Tee Joint Assembly (For Round Pipe)	56	ACP-V6026A-L	AL Connection Piece	73
AA-002	Elbow Joint Assembly	56	ACP-V6026A-R	AL Connection Piece	73
AA-004	Straight Joint Assembly	56	ACY-06A	Mount Bracket (General Use)	74
AA-007F	Swivel Joint Assembly (Rotation, Angle Adjust & Fix)	57	ACY-06B	Mount Bracket (General Use)	74
AA-007R	Swivel Joint Assembly (Rotation, Angle Adjustable)	57	ACY-07A	Slot Adaptor (for 40x40 AL Profile)	74
AA-009	Double Tee Joint Assembly	58	ACY-08A	Slot Adaptor (for 45x45 AL Profile)	74
AA-013	45 ° Joint Assembly	58	ACY-09A	Slot Adaptor (for 45x45 AL Profile)	74
AA-021	Single Tee Joint Assembly	58	ACY-303A	Roller Track Guide Bracket	66
AA-023	Stop Joint Assembly	58	ACY-303B	Roller Track Guide Bracket	66
AA-027F	Swivel Joint Assembly (Angle Adjust & Fix)	57	ACY-311A	Panel Cover (For Corner)	69
AA-027M	Swivel Joint Assembly (Angle Adjustable)	57	ACY-312A	AL Sheet Guide (For Panel Cover)	69
AA-028	Parallel Joint Assembly	59	ACY-313A	Panel Cover (For Outer Pipe)	69
AA-090	90 ° Elbow Joint Assembly	59	ACY-313B	Panel Cover (For Inner Pipe)	69
AA-101	Single Tee Joint Assembly	59	ACY-314A	Cover for Pipe Roller Guide	83
AA-104	Profile Joint Assembly	92	ACY-315C	Plastic Leveling Foot (For M6 Bolt)	70
AA-201	Single Tee Joint Assembly	59	ACY-317A	Groove Cover	120
AA-301	Single Tee Joint Assembly	86	ACY-318A	Pipe Connecting Adapter	70
AA-401	Single Tee Joint Assembly	88	ACY-318B	Pipe Connecting Adapter	70
AA-401W	Single Tee Joint Assembly (Heavy Duty)	88	ACY-A306	AL Roller Guide	67
AA-407F	Swivel Joint Assembly (Angle Adjust & Fix)	88	ACY-N301	Plastic Cable Holder	66
AA-413	45 ° Joint Assembly	88	ACY-N307	Slot Adaptor (for T-Slot Pipe)	75
AA-421	Single Tee Joint Assembly (Heavy Duty)	89	AD2812	Φ28 Heavy Duty Double Pipe	51
AA-490	90 ° Elbow Joint Assembly	89	AD2812H	Φ28 Extra Heavy Duty Double Pipe	51
ABS-0530	Board Support for Φ43	92	AD2829	Φ28 Extra Heavy Duty Double Pipe	51
ABS-4320A	Board Support for Φ43	93	AD30PA	Leveling Foot	212
ABS-4320C	Board Support for Φ43	93	AD32RA	Rubber Pad Leveling Foot	213
ABS-4320D	Board Support for Φ43	93	AD32RA-E	Rubber Pad Leveling Foot	213
ABS-4320E	Board Support for Φ43	93	AD32RA-EM	Rubber Pad Leveling Foot	213
ABS-600SA	Board Support 4MT	65	AD32RA-M	Rubber Pad Leveling Foot	213

INDEX

Part No.	Part Name (KR)	Page	Part No.	Part Name (KR)	Page
AD32RB	Rubber Pad Leveling Foot	213	AL2813	Φ28 Round Pipe (For Metal Joint)	50
AD32RB-E	Rubber Pad Leveling Foot	213	AL2818	Φ28 Round Pipe (For Metal Joint)	50
AD32RB-EM	Rubber Pad Leveling Foot	213	AL-4	L-Type Plastic Channel	219
AD32WA	Leveling Foot	212	AL-5	L-Type Plastic Channel	219
AD32WB	Leveling Foot	212	AL-5B	L-Type Plastic Channel	219
AD32WB-M	Leveling Foot	212	AL-6	L-Type Plastic Channel	219
AD32WC	Leveling Foot	212	AL-6B	L-Type Plastic Channel	219
AD32WC-M	Leveling Foot	212	AL-7	L-Type Plastic Channel	219
AD32WD	Leveling Foot	212	AL-7B	L-Type Plastic Channel	219
AD35SA	Leveling Foot	213	AL-8	L-Type Plastic Channel	219
AD35SB	Leveling Foot	213	AL-9	L-Type Plastic Channel	219
AD40SPA	Rubber Leveling Foot	213	ALF2812	Φ28 L-Flat Pipe	55
AD40SPA-E	Rubber Leveling Foot	213	ALF2812B	Φ28 L-Flat Pipe (Safety Cap Attachable)	55
AD40SPB	Rubber Leveling Foot	213	ALS2812	Φ28 L-Slide Pipe	52
AD40SPB-E	Rubber Leveling Foot	213	AMB-0654	Mount Bracket	95
AD4319	Φ43 Extra Heavy Duty Double Pipe	87	AMB-0684	Mount Bracket	95
AD50RAN	Rubber Pad Leveling Foot	213	ANP-01	AL Name Plate 4MT	78
AD50RAN-E	Rubber Pad Leveling Foot	213	ANP-01-150	AL Name Plate	78
AD50RAN-EM	Rubber Pad Leveling Foot	213	AOS-28A	Back Stopper	78
AD50RAN-H	Hexagon Leveling Foot	212	AP2812	Φ28 Regular Duty Pipe	49
AD50RAN-M	Rubber Pad Leveling Foot	213	AP2812H	Φ28 Extra Heavy Duty Pipe	49
AD50RBN	Rubber Pad Leveling Foot	213	AP2820	Φ28 Light Heavy Duty Pipe	49
AD50RBN-E	Rubber Pad Leveling Foot	213	AP2829	Φ28 Heavy Duty Pipe	49
AD50RDN-M	Rubber Pad Leveling Foot	213	AP3315	Φ33 Regular Duty Pipe	85
AD50REN	Rubber Pad Leveling Foot	213	AP3315H	Φ33 Heavy Duty Pipe	85
AD50WA	Leveling Foot	212	AP4319C	Φ43 Regular Duty Pipe	87
AD50WA-AC	Leveling Foot	212	AP4319H	Φ43 Extra Heavy Duty Pipe	87
AD50WB	Leveling Foot	212	AP-50	Anchor Plate (Prevention from moving by shake & shock)	231
AD50WB-AC	Leveling Foot	212	AP-60	Anchor Plate (Prevention from moving by shake & shock)	231
AD50WB-M	Leveling Foot	212	APC-01	Pipe Cover	78
AD50WD	Leveling Foot	212	APC-03	Pipe Cover	78
AD50WD-AC	Leveling Foot	212	APH-3027A	Round Pipe Connected Joint	79
AD50WE	Leveling Foot	212	APH-3027B	Round Pipe Connected Joint	79
AD50WE-AC	Leveling Foot	212	APHA-3027	Round Pipe Connected Joint Assembly	79
ADA-SM43A	Stanchion Mount Single Assembly	94	APHA-633N	Round Pipe Connected Joint	79
ADA-SM43L	Stanchion Mount Single-Left Assembly	94	AQ2812	Φ28 Hand Rail Pipe	49
ADA-SM43R	Stanchion Mount Single-Right Assembly	94	AQ4320	Φ43 Hand Rail AL Pipe	87
ADR-05	Door Rail	73	AR2812	Φ28 Round Pipe (Regular Duty)	50
AD-SM	Stanchion Mount Single	231	AR2820	Φ28 Round Pipe (Light Heavy Duty)	50
AD-SM43A	Stanchion Mount Single	94	AR2829	Φ28 Round Pipe (Heavy Duty)	50
AD-SM43L	Stanchion Mount Single-Left	94	ARG-35B	Box Guide-ESD	161
AD-SM43R	Stanchion Mount Single-Right	94	ARG-35BN	Box Guide-ESD	161
ADT-06	Slot Adapter (for T-Slot Pipe)	75	ARG-35C	Box Guide-ESD	162
ADT-08	Slot Adapter (for T-Slot Pipe)	75	ARG-4030BL	Box Guide-ESD	162
ADT-5H	Slot Adapter (for T-Slot Pipe)	75	ARG-4032AN	Box Guide-ESD	162
AFS2810	Φ28 Full Slide Pipe (Light Duty)	52	ARG-4032BN	Box Guide-ESD	162
AFS2812	Φ28 Full Slide Pipe (Regular Duty)	52	ARG-4035BS	Box Guide-ESD (For GP-4035BS)	163
AFU-28A	AL Folding Unit	76	ARG-4045B	Box Guide-ESD	163
AFU-28C	AL Folding Unit	76	ARG-40A	Box Guide-ESD	162
AFU-28S	AL Folding Unit	76	ARG-40C	Box Guide-ESD	163
AGP-28A	Φ28 Panel Frame Guide AL Pipe	53	ARG-40D	Box Guide-ESD	163
AGP-28B	Φ28 Panel Frame Guide AL Pipe (Joint Type)	53	ARG-40F	Box Guide-ESD	163
AH-540	Rotatable AL Sleeve (Short Type)	77	ARG-60C	Box Guide-ESD	164
AH-555	Rotatable AL Sleeve (Long Type)	77	ARU-28A	AL Rotary Unit	68
AH-640	AL Sleeve (Short Type)	77	AS-1	S-Type Plastic Channel	219
AH-655	AL Sleeve (Long Type)	77	AS-2	S-Type Plastic Channel	219
AH-800	AL Sleeve (Long Type)	77	AS2807A	Thread Insert	214
AHRG-35B	Box Guide-ESD	161	AS2807B	Thread Insert	214
AHRG-40B	Box Guide-ESD	161	AS-3	S-Type Plastic Channel	219
AHRG-60B	Box Guide-ESD	161	ASC-H42L	Horizontal Safety Cap	165
AL-1	L-Type Plastic Channel	219	ASC-H42R	Horizontal Safety Cap	165
AL-10	L-Type Plastic Channel	219	ASC-V30	Vertical Safety Cap	165
AL-2	L-Type Plastic Channel	219			

INDEX

Part No.	Part Name (KR)	Page	Part No.	Part Name (KR)	Page
ASC-V45	Vertical Safety Cap	165	B-101	Single Tee Joint	64
ASG-03	AL Sheet Guide	79	B-145	Corner Joint	64
ASG-05	AL Sheet Guide	79	B-206A	Crossover Joint (Angle Adjustable)	64
ASG-05B	AL Sheet Guide	80	B-206B	Crossover Joint (Angle Adjustable)	64
ASG-28A	Box Guide-ESD	164	B-206C	Crossover Joint (Angle Adjustable)	64
ASG-28B	Box Guide-ESD	164	B-206D	Crossover Joint (Angle Adjustable)	64
ASG-28C	Box Guide-ESD	164	B-301	Single Tee Joint	86
ASG-4305	AL Sheet Guide for $\Phi 43$	96	B-401	Single Tee Joint	90
ASGP-08	$\Phi 28$ Panel Guide Pipe	54	B-407A	Swivel Joint (Rotation, Angle Adjust & Fix)	90
ASJ4040A	40X40 90° 2-Way Joint Linking Profile	104	B-407B	Swivel Joint (Rotation, Angle Adjust & Fix)	90
ASJ4040B	40X40 180° 2-Way Joint Linking Profile	104	B-407C	Swivel Joint (Rotation, Angle Adjust & Fix)	90
ASJ4040C	40X40 1-Way Joint Linking Profile	104	B-411	Parallel Joint	91
ASJ4040D	40X40 Profile to Prevent Foreign Particles from Entering	104	B-444	Straight Connector Joint	91
ASJ4040E	40X40 3-Way Joint Linking Profile	105	B-445	Corner Joint	91
ASJ4040R	40X40 Corner Round 2-Way Joint Linking Profile	105	B-490	90° Elbow Joint	91
ASJ4545A	45X45 90° 2-Way Joint Linking Profile	110	BA-001	Single Tee Joint Assembly	60
ASJ4545C	45X45 1-Way Joint Linking Profile	110	BA-001C	Single Tee Joint Assembly (Pipe Angle Adjustable)	60
ASJ4545D	45X45 Profile to Prevent Foreign Particles from Entering	110	BA-001H	Single Tee Joint Assembly (Heavy Duty)	60
ASM4040A	40X40 Combination Profile (3-Way T-Groove, 1-Way Joint Linking)	105	BA-006	90° Offset Joint Assembly	60
ASM4040R	40X40 Corner Round Combination Profile (1-Way T-Groove, 1-Way Joint Linking)	105	BA-007F	Swivel Joint Assembly (Rotation, Angle Adjust & Fix)	61
ASM4545C	45X45 Combination Profile (3-Way T-Groove, 1-Way Joint Linking)	111	BA-007R	Swivel Joint Assembly (Rotation, Angle Adjustable)	61
ASQ2812A	28X28 90° 2-Way Linking Square Pipe	99	BA-008	Parallel Joint Assembly	62
ASQ2812B	28X28 180° 2-Way Linking Square Pipe	99	BA-011	Parallel Joint Assembly	62
ASQ2812C	28X28 1-Way Linking Square Pipe	99	BA-013	45° Joint Assembly	62
ASQ2812D	28X28 Square Pipe to Prevent Foreign Particles from Entering	99	BA-027F	Swivel Joint Assembly (Angle Adjust & Fix)	61
ASQ2812E	28X28 3-Way Linking Square Pipe	99	BA-027M	Swivel Joint Assembly (Angle Adjustable)	61
ASQ2812F	28X28 L-Type Square Pipe to Prevent Foreign Particles from Entering	100	BA-044B	Straight Connector Joint Assembly	63
ASR-52	Slot Roller	80	BA-045	Corner Joint Assembly	63
AST4040A	40X40 90° 2-Way T-Groove Profile	106	BA-090	90° Elbow Joint Assembly	63
AST4040D	40X40 4-Way T-Groove Profile	106	BA-091	90° Elbow Joint Assembly	63
AST4545A	45X45 90° 2-Way T-Groove Profile	111	BA-101	Single Tee Joint Assembly	64
AST4545D	45X45 4-Way T-Groove Profile	111	BA-145	Corner Joint Assembly	64
AT-1	T-Type Plastic Channel	219	BA-206	Crossover Joint Assembly (Angle Adjustable)	64
AT-2	T-Type Plastic Channel	219	BA2800A	AL Thread Insert	80, 217
AT2829	$\Phi 28$ T Slot Pipe	54	BA2800B	AL Thread Insert	80, 217
AT-3	T-Type Plastic Channel	219	BA280LA	Metal Thread Insert	80, 217
ATF2812	$\Phi 28$ T-Flat Pipe	55	BA280LB	Metal Thread Insert	80, 217
AU-1	U-Type Plastic Channel	219	BA280LD	Metal Thread Insert	80, 217
AU-2	U-Type Plastic Channel	219	BA280LE	Metal Thread Insert	80, 217
B			BA2818E	Metal Thread Insert (For AL2818)	81, 217
B-001	Single Tee Joint	60	BA-301	Single Tee Joint Assembly	86
B-001C	Single Tee Joint (Pipe Angle Adjustable)	60	BA3300A	Metal Thread Insert	86, 217
B-001H	Single Tee Joint (Heavy Duty)	60	BA3300B	Metal Thread Insert	86, 217
B-006	90° Offset Joint	60	BA3300D	Metal Thread Insert	86, 217
B-007A	Swivel Joint (Rotation, Angle Adjust & Fix)	57, 61	BA-401	Single Tee Joint Assembly	90
B-007B	Swivel Joint (Angle Adjust & Fix)	61	BA4040A	Aluminum Bushing for 40x40	109, 218
B-007C	Swivel Joint (Angle Adjustable)	61	BA4040B	Aluminum Bushing for 40x40	109, 218
B-007D	Swivel Joint (Rotation, Angle Adjustable)	61	BA-407F	Swivel Joint Assembly (Rotation, Angle Adjust & Fix)	90
B-008	Parallel Joint	62	BA-411	Parallel Joint Assembly	91
B-011	Parallel Joint	62	BA-427F	Swivel Joint Assembly (Rotation, Angle Adjust & Fix)	90
B-013L	45° Joint	62	BA4300A	AL Thread Insert	96, 217
B-013R	45° Joint	62	BA4300B	AL Thread Insert	96, 217
B-017A-08	Panel Joint	62	BA4300D	AL Thread Insert	96, 217
B-044B	Straight Connector Joint	63	BA4300N	AL Cap	96
B-045	Corner Joint	63	BA-444	Straight Connector Joint Assembly	91
B-050A	Corner Bracket for T-Groove Assembly (M6)	108	BA-445	Corner Joint Assembly	91
B-060A	Corner Bracket for T-Groove Assembly (M6)	108	BA4545A	Aluminum Bushing for 45x45	112, 218
B-080A	Corner Bracket for T-Groove Assembly (M8)	112	BA4545B	Aluminum Bushing for 45x45	112, 218
B-090	90° Elbow Joint	63	BA-490	90° Elbow Joint Assembly	91
B-091	90° Elbow Joint	63	BB01	Ball Bearing	226
			BC2807A	Thread Insert	214
			BC2807B	Thread Insert	214
			BC2807D	Thread Insert	214

INDEX

Part No.	Part Name (KR)	Page
BC2809A	Thread Insert	214
BC2809B	Thread Insert	214
BC2810A	Thread Insert	214
BC2810B	Thread Insert	214
BC2810D	Thread Insert	214
BC2814A	Thread Insert	214
BC2814B	Thread Insert	214
BC2820A	Thread Insert	214
BC2820B	Thread Insert	214
BC2820D	Thread Insert	214
BC3210A	Thread Insert	214
BC3210B	Thread Insert	214
BC45-A	Base Corner	188
BC45-A2	Base Corner	188
BC45-B	Base Corner	188
BC45-C	Base Corner	188
BH-A	Band Hook	198
BH-B	Band Hook	198
BL28YA-U	Pipe Holder	197
BP2800H	AL Plastic Thread Insert	81, 217
BP2828A	Bushing Cap for 28x28	101
BP4300H	AL Plastic Thread Insert	97, 217
BRA-32	Bearing Pulley	207
BS-01	Box Stopper	167
BS07A	Thread Insert	214
BS07B	Thread Insert	214
BS07D	Thread Insert	214
BS10A	Thread Insert	214
BS10B	Thread Insert	214
BS12A	Thread Insert	214
BS12B	Thread Insert	214
BS12D	Thread Insert	214
BS-15	Back Stopper Bracket	167
BUSH-12	Sleeve Bushing (Metal)	230
C		
C-001	Square Joint for 28x28	101
CA-001	Square Joint Assembly for 28x28	101
CB-MCP	Corner Bumper	185
CD-28C	Cable Duct	160
CD-28D	Cable Duct	160
CF2807	Flat Pipe	6
CF2809	Flat Pipe	6
CF2810	Flat Pipe	6
CFG-28A	Chassis Frame Guide	221
CL2807	Black Stripe Pipe (ESD)	6
CL2810	Black Stripe Pipe (ESD)	6
CM-100	Caster Mount Strap	183
CM-200	Caster Mount Strap	183
CM-200K	Caster Mount Strap	183
CM-230	Caster Mount Strap	183
CM-230K	Caster Mount Strap	183
CM-300	Caster Mount Strap	184
CM-330	Caster Mount Strap	184
CM-A	Corner Metal	190
CM-B	Corner Metal	190
CP-32	Wire Holder (Wire Falling Preventor)	207
CS2807	Slide Pipe	6
CS2809	Slide Pipe	6
CS2810	Slide Pipe	6
CS2820	Slide Pipe	6
CS28L	Corner Support	189
CS28R	Corner Support	189
D		

Part No.	Part Name (KR)	Page
D-001	Square Joint for 40x40	108
DA-001	Square Joint Assembly for 40x40	108
DL-15	Door Latch	228
DP2807	D-Coated Pipe	6
DP2809	D-Coated Pipe	6
DP2810	D-Coated Pipe	6
DP2814	D-Coated Pipe	6
DP2820	D-Coated Pipe	6
DP3210	D-Coated Pipe	6
DP-A	Dust Plate	160
DR-40R	Decelerating Roller	128
E		
E-001	Square Joint for 45x45	112
EA-001	Square Joint Assembly for 45x45	112
EAL-1	L-Type Plastic Channel (ESD)	219
EAL-10	L-Type Plastic Channel (ESD)	219
EAL-2	L-Type Plastic Channel (ESD)	219
EAL-4	L-Type Plastic Channel (ESD)	219
EAL-5	L-Type Plastic Channel (ESD)	219
EAL-5B	L-Type Plastic Channel (ESD)	219
EAL-6	L-Type Plastic Channel (ESD)	219
EAL-6B	L-Type Plastic Channel (ESD)	219
EAL-7	L-Type Plastic Channel (ESD)	219
EAL-7B	L-Type Plastic Channel (ESD)	219
EAL-8	L-Type Plastic Channel (ESD)	219
EAL-9	L-Type Plastic Channel (ESD)	219
EAS-1	S-Type Plastic Channel (ESD)	219
EAS-2	S-Type Plastic Channel (ESD)	219
EAS-3	S-Type Plastic Channel (ESD)	219
EAT-1	T-Type Plastic Channel (ESD)	219
EAT-2	T-Type Plastic Channel (ESD)	219
EAT-3	T-Type Plastic Channel (ESD)	219
EAU-1	U-Type Plastic Channel (ESD)	219
EAU-2	U-Type Plastic Channel (ESD)	219
ECH-28A	End Cap Hanger	201
EF2807	ESD Flat Pipe	6
EF2809	ESD Flat Pipe	6
EF2810	ESD Flat Pipe	6
EG2807	ESD Powder Pipe	6
EG2809	ESD Powder Pipe	6
EG2812	ESD Powder Pipe	6
EG2820	ESD Powder Pipe	6
EP2807	ESD D-Coated Pipe	6
EP2809	ESD D-Coated Pipe	6
EP2810	ESD D-Coated Pipe	6
EP2814	ESD D-Coated Pipe	6
EP2820	ESD D-Coated Pipe	6
EPC-01	Pipe-Cover Plastic Channel (ESD)	219
EPC-02	Pipe-Cover Plastic Channel (ESD)	219
ES2807	ESD Slide Pipe	6
ES2809	ESD Slide Pipe	6
ES2810	ESD Slide Pipe	6
ES2820	ESD Slide Pipe	6
EWS-A	Work Stopper	166
EWS-AN	Work Stopper	166
EWS-B	Work Stopper	166
EWS-C	Work Stopper	166
EWS-D	Work Stopper	166
EWS-E	Work Stopper	166
EWS-F	Work Stopper	166
EWS-F2	Work Stopper	166
EWS-G	Work Stopper	166
EWS-G2	Work Stopper	166

INDEX

Part No.	Part Name (KR)	Page	Part No.	Part Name (KR)	Page
EWS-GN	Work Stopper	166	FS302S-1B	Fastening Rubber Type Caster	173
EWS-GN2	Work Stopper	166	FS303R-1	Fastening Rubber Type Caster	173
EWS-H	Work Stopper	166	FS303S-1	Fastening Rubber Type Caster	173
EWS-J	Work Stopper	166	FS303S-1B	Fastening Rubber Type Caster	173
EWS-J2	Work Stopper	166	FS363R-4	Fastening Rubber Type Caster	173
EWS-K	Work Stopper	166	FS363S-1	Fastening Rubber Type Caster	173
EWS-MN	Work Stopper	166	FS363S-1B	Fastening Rubber Type Caster	173
EWS-PN	Work Stopper	166	FS363S-4	Fastening Rubber Type Caster	173
EWSR4040	Work Stopper	166	FS363S-4B	Fastening Rubber Type Caster	173
EWSR6016	Work Stopper	166	FS364R-1	Fastening Rubber Type Caster	173
EWSR6033	Work Stopper	166	FS364R-4	Fastening Rubber Type Caster	173
EWSR8523	Work Stopper	166	FS364S-1	Fastening Rubber Type Caster	173
EWSR8545	Work Stopper	166	FS364S-1B	Fastening Rubber Type Caster	173
F			FS364S-4	Fastening Rubber Type Caster	173
F-A	Handle (Flat Type)	201	FS364S-4B	Fastening Rubber Type Caster	173
FA302S-1	Fastening Rubber Type Caster for AL Rack	176	FS503S-1	Fastening Rubber Type Caster	173
FA302S-1B	Fastening Rubber Type Caster for AL Rack	176	FS503S-1B	Fastening Rubber Type Caster	173
FA303S-1	Fastening Rubber Type Caster for AL Rack	176	FS504R-2	Fastening Rubber Type Caster	173
FA303S-1B	Fastening Rubber Type Caster for AL Rack	176	FS-A	Front Haul Ass'y-Spring Type	193
FA363R-4	Fastening Rubber Type Caster for AL Rack	176	FS-AN-1	Front Haul Ring Ass'y	195
FA363S-1	Fastening Rubber Type Caster for AL Rack	176	FSD374S-1	Fastening Rubber Type Caster	173
FA363S-1B	Fastening Rubber Type Caster for AL Rack	176	FSD374S-1B	Fastening Rubber Type Caster	173
FA363S-4	Fastening Rubber Type Caster for AL Rack	176	G		
FA363S-4B	Fastening Rubber Type Caster for AL Rack	176	G-101	Metal Joint	16
FA364R-1	Fastening Rubber Type Caster for AL Rack	176	G-102	Metal Joint	16
FA364R-4	Fastening Rubber Type Caster for AL Rack	176	G-103	Metal Joint	16
FA364S-1	Fastening Rubber Type Caster for AL Rack	176	G-104	Metal Joint	16
FA364S-1B	Fastening Rubber Type Caster for AL Rack	176	G-105	Metal Joint	16
FA364S-4	Fastening Rubber Type Caster for AL Rack	176	G-106	Metal Joint	16
FA364S-4B	Fastening Rubber Type Caster for AL Rack	176	G-110S	Metal Joint	16
FB-28	Folding Bracket	230	G-12S	Metal Joint	12
FC302S-1	Fastening Rubber Type Caster	173	G-135S	Metal Joint	16
FC302S-1B	Fastening Rubber Type Caster	173	G-13AS	Metal Joint	12
FC303S-1	Fastening Rubber Type Caster	173	G-13BS	Metal Joint	12
FC303S-1B	Fastening Rubber Type Caster	173	G-14S	Metal Joint	12
FC363R-4	Fastening Rubber Type Caster	173	G-15AH	Metal Joint	12
FC363S-1	Fastening Rubber Type Caster	173	G-15AS	Metal Joint	12
FC363S-1B	Fastening Rubber Type Caster	173	G-15BL	Metal Joint	13
FC363S-4	Fastening Rubber Type Caster	173	G-15BS	Metal Joint	12
FC363S-4B	Fastening Rubber Type Caster	173	G-15D	Metal Joint	13
FC364R-1	Fastening Rubber Type Caster	173	G-15DL	Metal Joint	13
FC364R-4	Fastening Rubber Type Caster	173	G-15G	Metal Joint	13
FC364S-1	Fastening Rubber Type Caster	173	G-160S	Metal Joint	16
FC364S-1B	Fastening Rubber Type Caster	173	G-16S	Metal Joint	13
FC364S-4	Fastening Rubber Type Caster	173	G-16WP	Metal Joint	17
FC364S-4B	Fastening Rubber Type Caster	173	G-17S	Metal Joint	13
FC503S-1	Fastening Rubber Type Caster	173	G-18S	Metal Joint	13
FC503S-1B	Fastening Rubber Type Caster	173	G-1BS	Metal Joint	11
FC504S-2	Fastening Rubber Type Caster	173	G-1S	Metal Joint	11
FC504S-2B	Fastening Rubber Type Caster	173	G-20S	Metal Joint	13
FCD374S-1	Fastening Rubber Type Caster	173	G-22S	Metal Joint	13
FCD374S-1B	Fastening Rubber Type Caster	173	G-23S	Metal Joint	13
FG-01	Fork Guide	191	G-24S	Metal Joint	14
FG-03	Fork Guide	191	G-25AS	Metal Joint	14
FG-04	Fork Guide	192	G-25BS	Metal Joint	14
FQ-B	Front Haul Ass'y-Quicking Type	194	G-25C	Metal Joint	14
FQ-BL-1	Front Haul Ass'y-Quicking Type	194	G-28	Metal Joint	14
FS2807	Full Slide Pipe	6	G2807	Powder Pipe	6
FS2807-E	ESD Full Slide Pipe	6	G2809	Powder Pipe	6
FS2809	Full Slide Pipe	6	G2812	Powder Pipe	6
FS2809-E	ESD Full Slide Pipe	6	G2820	Powder Pipe	6
FS302R-1	Fastening Rubber Type Caster	173	G-2S	Metal Joint	11
FS302S-1	Fastening Rubber Type Caster	173	G-301	Metal Joint	16

INDEX

Part No.	Part Name (KR)	Page	Part No.	Part Name (KR)	Page
G-30S	Metal Joint	14	GA-3S	Metal Joint Assembly	18
G-34S	Metal Joint	14	GA-44	Metal Joint Assembly	24
G-35AS	Metal Joint	14	GA-45S	Metal Joint Assembly	25
G-35BS	Metal Joint	14	GA-4S	Metal Joint Assembly	18
G-38S	Metal Joint	14	GA-54S	Metal Joint Assembly	25
G-3S	Metal Joint	11	GA-55S	Metal Joint Assembly	25
G-44	Metal Joint	15	GA-5S	Metal Joint Assembly	19
G-45S	Metal Joint	15	GA-60S	Metal Joint Assembly	25
G-4S	Metal Joint	11	GA-65S	Metal Joint Assembly	25
G-54S	Metal Joint	15	GA-65S-10	Metal Joint Assembly	26
G-60S	Metal Joint	15	GA-66	Metal Joint Assembly	26
G-65S	Metal Joint	15	GA-6B-33	Metal Joint Assembly	19
G-65S-10	Metal Joint	15	GA-6BS	Metal Joint Assembly	19
G-66	Metal Joint	15	GA-6S	Metal Joint Assembly	19
G-6B-33	Metal Joint	11	GA-75	Metal Joint Assembly	26
G-6BS	Metal Joint	11	GA-7S	Metal Joint Assembly	19
G-6S	Metal Joint	11	GA-8S	Metal Joint Assembly	20
G-75A	Metal Joint	15	GA-90S	Metal Joint Assembly	26
G-75B	Metal Joint	15	GA-9S	Metal Joint Assembly	20
G-7AS	Metal Joint	11	GAM-07S	Metal Cap	215
G-7BS	Metal Joint	11	GAP-1	Plastic Joint	29
G-7CS	Metal Joint	12	GAP-10L	Plastic Joint (Left side handle)	32
G813R-2	Grip Ring Type Caster	172	GAP-10R	Plastic Joint (Right side handle)	32
G813S-2	Grip Ring Type Caster	172	GAP-11	Taper Edge	32
G813S-2B	Grip Ring Type Caster	172	GAP-12	Sleeve (For GA-12S/17S/18S/24S/25S)	32
G-8S	Metal Joint	12	GAP-13	Plastic Joint Corner	33
G-90S	Metal Joint	15	GAP-14	Plastic Joint Corner Cushion Type	33
G-9S	Metal Joint	12	GAP-15	Sheet Holder	33
GA-101	Metal Joint Assembly	26	GAP-16	Plastic Joint	33
GA-102	Metal Joint Assembly	27	GAP-17	Plastic Joint	33
GA-103	Metal Joint Assembly	27	GAP-18A	Plastic Joint	34
GA-104	Metal Joint Assembly	27	GAP-18B	Plastic Joint (Penetrated Model)	34
GA-105	Metal Joint Assembly	27	GAP-19	Plastic Joint	34
GA-106	Metal Joint Assembly	27	GAP-20	Name Plate Holder	34
GA-110S	Metal Joint Assembly	28	GAP-21A	Nut Block	226
GA-12S	Metal Joint Assembly	20	GAP-22A	Bearing Block	226
GA-135S	Metal Joint Assembly	28	GAP-23	Plastic Joint	34
GA-13S	Metal Joint Assembly	20	GAP-24A	Plastic Joint	35
GA-14S	Metal Joint Assembly	20	GAP-24B	Plastic Joint (Penetrated Model)	35
GA-15D	Metal Joint Assembly	21	GAP-25A	Plastic Joint	35
GA-15G	Metal Joint Assembly	21	GAP-25B	Plastic Joint (Penetrated Model)	35
GA-15H	Metal Joint Assembly	21	GAP-26A	Plastic Joint	35
GA-15L	Metal Joint Assembly	21	GAP-26B	Plastic Joint (Penetrated Model)	36
GA-15S	Metal Joint Assembly	21	GAP-27A	Plastic Joint	36
GA-160S	Metal Joint Assembly	28	GAP-27B	Plastic Joint (Penetrated Model)	36
GA-16S	Metal Joint Assembly	22	GAP-2828A	Inner Cap for 28x28	101
GA-17S	Metal Joint Assembly	22	GAP-2828D	Inner Cap for 28x28	101
GA-18S	Metal Joint Assembly	22	GAP-2828E	Inner Cap for 28x28	101
GA-1BS	Metal Joint Assembly	18	GAP-28A	Plastic Joint	36
GA-1S	Metal Joint Assembly	18	GAP-28B	Plastic Joint (Penetrated Model)	36
GA-20S	Metal Joint Assembly	22	GAP-29A	Plastic Joint	37
GA-23S	Metal Joint Assembly	22	GAP-29B	Plastic Joint (Penetrated Model)	37
GA-24S	Metal Joint Assembly	23	GAP-2A	Plastic Joint	29
GA-25C	Metal Joint Assembly	23	GAP-2B	Plastic Joint (Penetrated Model)	29
GA-25S	Metal Joint Assembly	23	GAP-3	Outer Cap	29
GA-27S	Metal Joint Assembly	23	GAP-30A	Plastic Joint	37
GA-28	Metal Joint Assembly	23	GAP-30B	Plastic Joint	37
GA-2S	Metal Joint Assembly	18	GAP-31	Plastic Joint	37
GA-301	Metal Joint Assembly	28	GAP-33A	Plastic Inner Cap	86
GA-30S	Metal Joint Assembly	24	GAP-34	Plastic Joint	38
GA-34S	Metal Joint Assembly	24	GAP-35	Plastic Joint	38
GA-35S	Metal Joint Assembly	24	GAP-37A	Plastic Joint	38
GA-38S	Metal Joint Assembly	24	GAP-37B	Plastic Joint	38

INDEX

Part No.	Part Name (KR)	Page
GAP-39	Plastic Joint	38
GAP-3A	Outer Cap	81
GAP-40	Plastic Joint	39
GAP-4040A	Inner Cap for 40x40	109
GAP-4040D	Inner Cap for 40x40	109
GAP-4040R	Inner Cap for 40x40	109
GAP-41	Plastic Joint	39
GAP-42	Plastic Joint	39
GAP-43	Plastic Joint	39
GAP-4310-B	Inner Cap	214
GAP-4310-G	Inner Cap	214
GAP-4310-i	Inner Cap	214
GAP-43A	Plastic Inner Cap	97
GAP-43B	Plastic Round Inner Cap	97
GAP-44	Sleeve (For GA-12S/17S/18S/24S/25S)	39
GAP-4545D	Inner Cap for 45x45	112
GAP-45A	Plastic Joint	40
GAP-45B	Plastic Joint (Penetrated Model)	40
GAP-46	Plastic Joint	40
GAP-47	Plastic Joint (Length adjustment)	40
GAP-48	Roller Conveyor Holder (Single)	41
GAP-49	Roller Conveyor Holder (Double)	41
GAP-4A	Inner Cap	81
GAP-4AT	Inner Cap (For AT2829)	81
GAP-4C	Inner Cap	30
GAP-4C-B	Inner Cap	214
GAP-4C-G	Inner Cap	214
GAP-4C-i	Inner Cap	214
GAP-4H	Inner Cap	81
GAP-4P	Inner Cap	29
GAP-4P-B	Inner Cap	214
GAP-4P-G	Inner Cap	214
GAP-4P-i	Inner Cap	214
GAP-4R	Rubber Cap	30
GAP-4R-B	Inner Cap	214
GAP-4S	Inner Cap	30
GAP-4S-B	Inner Cap	214
GAP-4S-G	Inner Cap	214
GAP-4S-i	Inner Cap	214
GAP-5	Plastic Joint Corner	30
GAP-50	Roller Conveyor Cap (Without Bearing)	41
GAP-51	Roller Conveyor Support	41
GAP-52A	Roller Conveyor Cap (With Bearing)	41
GAP-53	Plastic Joint	40
GAP-54	Plastic Joint	42
GAP-55	Name Plate Holder (Assemble with NP-B or NP-M)	42
GAP-56	Sleeve (For GA-35S)	42
GAP-58	Name Plate Holder (Assemble with NP-F)	42
GAP-6	Label Holder	30
GAP-61	Plastic Joint	42
GAP-64	Corner Support Joint	43
GAP-65	Corner Support Cap	43
GAP-66	Plastic Joint	43
GAP-6B	Label Holder	30
GAP-7	Plastic Joint	31
GAP-71	Plastic Joint	43
GAP-72	Plastic Joint	43
GAP-73	Plastic Latch	44
GAP-74A	Plastic Latch	44
GAP-74B	Plastic Latch	44
GAP-75	Plastic Latch	44
GAP-79	Plastic Latch	45
GAP-8	Horizontal Holder	31

Part No.	Part Name (KR)	Page
GAP-80A	Plastic Latch	45
GAP-80B	Plastic Latch	45
GAP-81	Plastic Latch	45
GAP-82	Plastic Latch	45
GAP-83	Plastic Joint	46
GAP-84	Plastic Joint	46
GAP-8FN	Horizontal Holder (Flat Type)	31
GAP-9C-07	Grip Bushing (Coating Pipe:Φ28xT0.7)	31
GAP-9C-09	Grip Bushing (Coating Pipe:Φ28xT0.9)	31
GAP-9S-07	Grip Bushing (STS Pipe:Φ28xT0.9)	32
GAPA-76A	Plastic Joint	44
GAS-07A	Steel Cap	215
GAS-07S	Steel Cap	215
GAS-10A	Steel Cap	215
GAS-12S	Steel Cap	215
GB-02	Gap Bushing	207
GP-11	Adjustable Roller Union	145
GP-12	Adjustable Roller Union	145
GP-13	Adjustable Roller Union	145
GP-14	Adjustable Roller Union	145
GP3533B	Standard Roller Track 35 Series (Pitch: 33)	116
GP4025M	Standard Roller Track 40 Series (Pitch: 25)	117
GP4035BS	Standard Roller Track 40 Series (Pitch: 35)	116
GP4036A	Standard Roller Track 40 Series (Pitch: 36)	116
GP4036B	Standard Roller Track 40 Series (Pitch: 36)	116
GP4040A	Standard Roller Track 40 Series (Pitch: 40)	116
GP4040B	Standard Roller Track 40 Series (Pitch: 40)	117
GP4050C	Standard Roller Track 40 Series (Pitch: 50)	117
GP4050D	Standard Roller Track 40 Series (Pitch: 50)	117
GP6016S	Standard Roller Track 60 Series (Pitch: 16)	117
GP6033B	Standard Roller Track 60 Series (Pitch: 33)	118
GP6033HA	Standard Roller Track 60 Series (Pitch: 33)	118
GP8525M	Standard Roller Track 85 Series (Pitch: 25)	118
GP8543B	Standard Roller Track 85 Series (Pitch: 43)	118
GP-A	Roller Mounting Bracket	136
GP-A25	Roller Mounting Bracket	132
GP-A33	Roller Mounting Bracket	136
GP-A35	Roller Mounting Bracket	133
GP-A60	Roller Mounting Bracket	146
GP-A60-33	Roller Mounting Bracket	146
GP-A85	Roller Mounting Bracket	151
GP-A85-33	Roller Mounting Bracket	151
GP-AN85	Roller Mounting Bracket / Drop Stop	151
GP-APF	Roller Mounting Bracket	136
GP-APF60	Roller Mounting Bracket	146
GP-B	Roller Mounting Bracket / Tab Stop	136
GP-B-1	Roller Mounting Bracket / Tab Stop	137
GP-B-1-33	Roller Mounting Bracket / Tab Stop	137
GP-B25	Roller Mounting Bracket / Tab Stop	132
GP-B33	Roller Mounting Bracket / Tab Stop	136
GP-B35	Roller Mounting Bracket / Tab Stop	133
GP-B35-1	Roller Mounting Bracket / Tab Stop	133
GP-B35-1-33	Roller Mounting Bracket / Tab Stop	133
GP-B35-33	Roller Mounting Bracket / Tab Stop	133
GP-B60	Roller Mounting Bracket / Tab Stop	146
GP-B60-1	Roller Mounting Bracket / Tab Stop	147
GP-B60-33	Roller Mounting Bracket / Tab Stop	146
GP-B85	Roller Mounting Bracket / Tab Stop	151
GP-B85-1	Roller Mounting Bracket / Tab Stop	152
GP-B85-1-33	Roller Mounting Bracket / Tab Stop	152
GP-B85-2	Roller Mounting Bracket / Tab Stop	152
GP-B85-33	Roller Mounting Bracket / Tab Stop	152
GP-B85-N	Roller Mounting Bracket / Tab Stop	151

INDEX

Part No.	Part Name (KR)	Page	Part No.	Part Name (KR)	Page
GP-C	Roller Track Union	137	GP-M60	Roller Mounting Bracket	150
GP-C-1	Roller Track Union / Center Support	137	GP-M85	Roller Mounting Bracket	154
GP-C-1-33	Roller Track Union / Center Support	137	GP-M85-33	Roller Mounting Bracket	154
GP-C35	Roller Track Union	134	GP-NA	Roller Mounting Bracket	144
GP-C85	Roller Track Union	152	GP-NB	Roller Mounting Bracket / Tab Stop	144
GP-C85-1	Roller Track Union / Center Support	153	GPR1021BFS-AL	Silent Roller Track 100 Series (Pitch: 21)	123
GP-CN	Roller Track Union	138	GPR2528A-AL	Silent Roller Track 25 Series (Pitch: 28.6)	119
GP-CN60	Roller Track Union	147	GPR4040A-AL	Silent Roller Track 40 Series (Pitch: 40)	119
GP-D35	Roller Mounting Bracket / Drop Stop	134	GPR4040A-GI	Silent Roller Track 40 Series (Pitch: 40)	119
GP-D60	Roller Mounting Bracket / Drop Stop	147	GPR4040B-AL	Silent Roller Track 40 Series (Pitch: 40)	119
GP-D60-33	Roller Mounting Bracket / Drop Stop	147	GPR4040B-GI	Silent Roller Track 40 Series (Pitch: 40)	119
GP-D85	Roller Mounting Bracket / Drop Stop	153	GPR4040SR-AL	STS Covered Roller Track 40 Series (Pitch: 40)	124
GP-DF	Roller Mounting Bracket / Drop Stop	138	GPR4040SR-GI	STS Covered Roller Track 40 Series (Pitch: 40)	124
GP-DF-40	Roller Mounting Bracket / Drop Stop	138	GPR4055C-AL	Silent Roller Track 40 Series (Pitch: 55)	119
GP-DF60J	Roller Mounting Bracket	147	GPR4055C-GI	Silent Roller Track 40 Series (Pitch: 55)	119
GP-DFJ	Roller Mounting Bracket	138	GPR6016S-AL	Silent Roller Track 60 Series (Pitch: 16)	121
GP-DN	Roller Mounting Bracket / Drop Stop	138	GPR6016S-GI	Silent Roller Track 60 Series (Pitch: 16)	121
GP-DN33	Roller Mounting Bracket / Drop Stop	139	GPR6033B-AL	Silent Roller Track 60 Series (Pitch: 33)	121
GP-E	Roller Mounting Bracket / Center Support	139	GPR6033B-GI	Silent Roller Track 60 Series (Pitch: 33)	121
GP-E25	Roller Mounting Bracket / Center Support	132	GPR6033HA-AL	Silent Roller Track 60 Series (Pitch: 33)	122
GP-E33	Roller Mounting Bracket / Center Support	139	GPR6033HA-GI	Silent Roller Track 60 Series (Pitch: 33)	121
GP-E35	Roller Mounting Bracket / Center Support	134	GPR8523S-AL	Silent Roller Track 85 Series (Pitch: 23)	122
GP-E35-A12	Roller Mounting Bracket / Center Support	134	GPR8523S-GI	Silent Roller Track 85 Series (Pitch: 23)	122
GP-E60	Roller Mounting Bracket / Center Support	148	GPR8523SR-AL	STS Covered Roller Track 85 Series (Pitch: 23)	124
GP-E60-33	Roller Mounting Bracket / Center Support	148	GPR8523SR-GI	STS Covered Roller Track 85 Series (Pitch: 23)	124
GP-E85	Roller Mounting Bracket / Center Support	153	GPR8545B-AL	Silent Roller Track 85 Series (Pitch: 45)	122
GP-E85-33	Roller Mounting Bracket / Center Support	153	GPR8545B-GI	Silent Roller Track 85 Series (Pitch: 45)	122
GP-EH60	Roller Mounting Bracket / Center Support	148	GPR8545HA-AL	Silent Roller Track 85 Series (Pitch: 45)	123
GP-EN	Roller Mounting Bracket / Center Support	139	GPR8545HA-GI	Silent Roller Track 85 Series (Pitch: 45)	123
GP-EN60	Roller Track Union / Center Support	148	GPR8545SR-AL	STS Covered Roller Track 85 Series (Pitch: 45)	125
GP-EN85	Roller Track Union / Center Support	153	GPR8545SR-GI	STS Covered Roller Track 85 Series (Pitch: 45)	124
GP-EW	Roller Mounting Bracket	139	GPRG4040B	Guide Type Roller Track 40 Series (Pitch:40)	120
GP-EW-33	Roller Mounting Bracket	140	GP-SB	Absorber Mounting Bracket	144
GP-F	Roller Mounting Bracket	140	GP-VA35	Roller Mounting Bracket	135
GP-F-33	Roller Mounting Bracket	140	GP-VA40	Roller Mounting Bracket	144
GP-F-40	Roller Mounting Bracket	140	GRH-15L	Pulley Holder Bracket (Left)	205
GP-FA	Roller Mounting Bracket	140	GRH-15R	Pulley Holder Bracket (Right)	205
GP-FC	Roller Mounting Bracket / Tab Stop	141	GRHA-15L	Bearing Pulley Ass'y (Left)	205
GP-FC60	Roller Mounting Bracket	148	GRHA-15R	Bearing Pulley Ass'y (Right)	205
GP-G	Roller Mounting Bracket / Tab Stop	141	GRV-15L	Pulley Holder Bracket (Left)	206
GP-G-33	Roller Mounting Bracket	141	GRV-15R	Pulley Holder Bracket (Right)	206
GP-HF	Roller Track Union	141	GRVA-15L	Bearing Pulley Ass'y (Left)	206
GP-HN	Roller Track Union	141	GRVA-15R	Bearing Pulley Ass'y (Right)	206
GP-HN-33	Roller Mounting Bracket	142	GS-1014A	Sleeve Hanger	199
GP-HN35	Roller Track Union	134	GS-1014B	Sleeve Hanger	200
GP-HN60	Roller Track Union	149	GS-1014CH	Sleeve Hanger (2 Hole)	199
GP-HP	Roller Track Union	142	GS-1024B	Sleeve Hanger	200
GP-HS	Adjustable Roller to Slide Pipe Union	142	GS-1044B	Sleeve Hanger	200
GP-HU	Roller Track Union	142	GS-11	Adjustable Slide Pipe Union	157
GP-K	Roller Mounting Bracket	142	GS-1250A	End Snap Rest	180
GP-L	Roller Mounting Bracket	143	GS-1250B	End Snap Rest	180
GP-L-33	Roller Mounting Bracket	143	GS-2070C	Pipe Plug	182
GP-L60	Roller Mounting Bracket	149	GS-2070C-C07	Pipe Plug	182
GP-L60W	Roller Mounting Bracket	149	GS-2070C-C09	Pipe Plug	182
GP-L60W-33	Roller Mounting Bracket	149	GS-2070C-C10	Pipe Plug	182
GP-L60WB	Roller Mounting Bracket / Tab Stop	149	GS-2070C-C20	Pipe Plug	182
GP-L85W	Roller Mounting Bracket	154	GS-2070C-S07	Pipe Plug	182
GP-L85W-33	Roller Mounting Bracket	154	GS-2070C-S10	Pipe Plug	182
GP-LW	Roller Mounting Bracket	143	GS-2070C-S12	Pipe Plug	182
GP-LW-33	Roller Mounting Bracket	143	GS-2070D	Slide Pipe Plug	182
GP-LWB	Roller Mounting Bracket / Tab Stop	143	GS-2070D-C07	Slide Pipe Plug	182
GP-M	Roller Mounting Bracket	144	GS-2070D-C20	Slide Pipe Plug	182
GP-M35	Roller Mounting Bracket	135	GS-2070D-S07	Slide Pipe Plug	182

INDEX

Part No.	Part Name (KR)	Page
GS-2070D-S10	Slide Pipe Plug	182
GS-2070D-S12	Slide Pipe Plug	182
GS-2070E	Slide Pipe Plug	182
GS-2070E-C09	Slide Pipe Plug	182
GS-A-33	Slide Pipe Mount	155
GS-AN	Slide Pipe Mount	155
GS-B-1	Slide Pipe Mount / Tap top	155
GS-B-33	Slide Pipe Mount / Tap top	155
GS-B33-1	Slide Pipe Mount / Tap top	156
GS-BN	Slide Pipe Mount / Tap top	155
GS-C	Slide Pipe Mount Guide Bracket	156
GS-D	Slide Pipe Mount / Drop top	156
GS-D-33	Slide Pipe Mount / Drop top	156
GS-E	Slide Pipe Mount Guide Bracket	156
GS-F	Box Guide Mount Bracket	157
GS-F40	Box Guide Mount Bracket	157
GS-HP	Slide Pipe Mount	157
H		
HC-1	Pipe Hand Cutter	224
HC28A	Hole Cup-A	232
HC40	Hole Cup	232
HD-80	Handle	226
HG-143 BK	Hand Grip	82
HG-143 PG	Hand Grip	82
HG-D	Hinge Metal	234
HG-D-BR	Hinge Metal	234
HK28WA	Pipe Rest	181
HK28WB	Pipe Rest	181
HK28WC	Pipe Rest	182
HM28YA	Hanger Metal	201
HM28YB	Hanger Metal	201
HP-30L	Holder Panel	236
HP-30R	Holder Panel	236
I		
IN304	Insert Nut	223
IN305	Insert Nut	223
IN306	Insert Nut	223
IN404	Insert Nut	223
IN405	Insert Nut	223
IN406	Insert Nut	223
IN408	Insert Nut	223
K		
KH-200-4	Floor Lock	178
KH-200-5	Floor Lock	178
KH-200-6	Floor Lock	178
KH-200-8	Floor Lock	178
KH-200-스텐	Floor Lock	178
KH-200-조절용	Floor Lock	178
L		
L-500	Lift Table Rail	226
L-750	Lift Table Rail	226
LA 215*160	2 Hole Label Case	211
LA 300*100	4 Hole Label Case	211
LA2 300*100	2 Hole Label Case	211
LA-A3 430*320	4 Hole Label Case	211
LA-B 300*120	4 Hole Label Case	211
LA-C 300*220	4 Hole Label Case	211
LA-C2 220*300	2 Hole Label Case	211
LA-D 150*60	1 Hole Label Case	211
LA-D3 150*60	3 Hole Label Case	211
LAD-A	Lifting Action Locking Device	82
LA-E 210*100	3 Hole Label Case	211
LA-G 230*95	3 Hole Label Case	211

Part No.	Part Name (KR)	Page
LA-H 170*135	1 Hole Label Case	211
LA-P 136*40	1 Hole Label Case	211
LA-R 105*100	1 Hole Label Case	211
LC 180*85	1 Hole Label Case	211
LC 250*100	4 Hole Label Case	211
LC 250*80	4 Hole Label Case	211
LC-B 210*80	3 Hole Label Case	211
LK28A	Pipe Connector (Coated Pipe)	238
LK28S	Pipe Connector (STS/ECCO Pipe)	238
LP2800	ELF Plate	82
LRA-19	Roller for Pipe Roller Guide	83
LS2809	L-Slide Pipe	6
LS2809-E	ESD L-Slide Pipe	6
LS2810	L-Slide Pipe	6
LS2810-E	ESD L-Slide Pipe	6
LT-500	Lift Table	225
LT-750	Lift Table	225
M		
MB-15	Monitor Bracket (VESA Hole standard)	227
MCA-304A	Metal Joint Divide	230
MCA-304B	Name Plate Holder	230
MCP-B3-L	Mount Corner Plate-Left	185
MCP-B3-R	Mount Corner Plate-Right	185
MCP-C3	Mount Center Plate	185
MCP-E	Mount Corner Plate	186
MCP-F-A	Metal Corner Plate	186
MCP-F-B	Metal Corner Plate	186
MCP-G	Metal Corner Plate	186
MCP-HN-L	Mount Corner Plate-Left	187
MCP-HN-R	Mount Corner Plate-Right	187
MCP-KN	Mount Center Plate	187
MCY-305A	Back Stopper Bracket	169
MCY-306A	Pipe Anchor Bracket	231
MCY-A301	One Touch Stopper-Right	168
MCY-E301	One Touch Stopper-Left	168
MCY-N302	Corner Bumper	234
MG21JE-S	Separator	236
MJC-G1	Metal Joint Cover	202
MJC-G2	Metal Joint Cover	202
MJC-G3	Metal Joint Cover	202
MJC-G4	Metal Joint Cover	202
MJC-G6S	Metal Joint Cover	202
MJC-G7A	Metal Joint Cover	203
MJC-G7B	Metal Joint Cover	203
N		
NP-A	Name Plate	208
NP-B	Name Plate	208
NP-C	Name Plate	208
NP-D	Name Plate	208
NP-E	Name Plate	208
NP-F	Name Plate (Requires GAP-58)	209
NP-F40	Name Plate (Requires GAP-58)	209
NP-G	Name Plate (Requires GAP-58)	209
NP-H	Name Plate (Double-sided adhesive tape type)	209
NP-K	Name Plate	210
NP-L	Name Plate (Double-sided adhesive tape type)	210
NP-M	Name Plate	210
NP-R	Name Plate	209
O		
OB28AN	Thread Insert	215
OB28BN	Thread Insert	215
P		
P363S-3	Top Plate Type Caster	174

INDEX

Part No.	Part Name (KR)	Page
RF-01	Rubber Foot	216
RF-01E	Rubber Foot	216
RF-02	Rubber Foot	216
RF-02 ESD	Rubber Foot	216
RF-02(Soft)	Rubber Foot	216
RG-35B	Box Guide	158
RG-40A	Box Guide	158
RG-40B	Box Guide	158
RG-40B40	Box Guide	159
RG-40C	Box Guide	159
RG-40D	Box Guide	159
RG-40E	Box Guide	159
RQ-B	Rear Haul Ass'y-Quicking Type	194
RQ-C	Rear Haul Ass'y-Quicking Type	195
RS-28	Safety Reflector	236
RS-A	Real Haul Ass'y-Spring Type	193
RS-AN-1	Rear Haul Ring Ass'y	195
S		
S2807A	Polished Pipe	6
S2809A	Polished Pipe	6
S2812A	Polished Pipe	6
SC-2845	Shaft Cylinder	229
SD2805	STS D-Coated Pipe	6
SG-01	Sheet Guide	159
SG-02	Sheet Guide	160
SG-03	Sheet Guide	160
SG-2860A	Box Guide	158
SG-28A	Box Guide	158
SN304	Spring Nut	223
SN305	Spring Nut	223
SN306	Spring Nut	223
SN404	Spring Nut	223
SN405	Spring Nut	223
SN406	Spring Nut	223
SN408	Spring Nut	223
SP2809	Spiral Pipe	6
SPS-0635	Spring Shaft	73
SR-40	Stop Roller	127
SR-60A	Stop Roller	127
SR-85A	Stop Roller	127
T		
T302S-1	Threaded Stem Type Caster	171
T302S-1B	Threaded Stem Type Caster	171
T302S-E	Threaded Stem Type Caster	171
T3625S-1	Threaded Stem Type Caster	171
T3625S-1B	Threaded Stem Type Caster	171
T3625S-2	Threaded Stem Type Caster	171
T3625S-2B	Threaded Stem Type Caster	171
T3625S-4	Threaded Stem Type Caster	171
T3625S-4B	Threaded Stem Type Caster	171
T3625S-E	Threaded Stem Type Caster	171
T363S-1	Threaded Stem Type Caster	171
T363S-1B	Threaded Stem Type Caster	171
T363S-3	Threaded Stem Type Caster	171
T363S-3B	Threaded Stem Type Caster	171
T363S-4	Threaded Stem Type Caster	171
T363S-4B	Threaded Stem Type Caster	171
T363S-E	Threaded Stem Type Caster	171
T503S-1	Threaded Stem Type Caster	172
T503S-1B	Threaded Stem Type Caster	172
T503S-2	Threaded Stem Type Caster	172
T503S-2B	Threaded Stem Type Caster	172
T503S-E	Threaded Stem Type Caster	172

Part No.	Part Name (KR)	Page
T504S-1	Threaded Stem Type Caster	172
T504S-1B	Threaded Stem Type Caster	172
T504S-2	Threaded Stem Type Caster	172
T504S-2B	Threaded Stem Type Caster	172
T504S-E	Threaded Stem Type Caster	172
TC-28	Tool Cap	229
TH40PA	Tool Holder	204
TH50PA	Tool Holder	204
TH50YA	Tool Holder	204
TH60PA	Tool Holder	204
TH60PB	Tool Holder	204
TH65YA	Tool Holder	204
TM16-500	Lift Table Screw Ass'y	226
U		
UR4050-AL	Universal Roller Track 40 Series (Pitch: 50)	126
UR6067-AL	Universal Roller Track 60 Series (Pitch: 67)	126
W		
WEIGHT	Weight for Automation	84
WL-250	Wire Latch	237
WR-19/22	Spanner for Caster	227
WR-200	Wire Rack	237
WT-2802	Weight for Automation	84
WT-2802B	Weight for Automation	84
WT-4305	Weight for Automation	84
WT-4305B	Weight for Automation	84
WT-4310	Weight for Automation	84
WT-4310B	Weight for Automation	84
WT-4320	Weight for Automation	84
WT-4320B	Weight for Automation	84
Z		
Z2808	Powder Pipe	6



AMS, INC. Advanced Mechatronics Solutions, Inc.

10030 Via de la Amistad, San Diego, CA 92154 ☎ +1 (619) 661-5985 📠 +1 (619) 661-5995 @ ams@ams-fa.com



AMS, Dynamics, Inc. Advanced Mechatronics Solutions, Dynamics, Inc.

2979 Pacific Drive Suite A Norcross, GA 30071 ☎ +1 (770) 864-5394 📠 +1 (678) 691-1847 @ infoATL@ams-fa.com



AMS de MEXICO AMS Factory Automation de Mexico SA de CV

Polígono Buenavista -- Calle Cementera Lote 9, Mz 8 Ejido Buenavista - Querétaro, Qro. 76225

☎ +52 (442)312-0920 @ mexico@ams-fa.com



AMS do BRASIL AMS do Brasil Automação Industrial Ltda

Rua Antonio Raposo Tavares, 363 Macuco. Valinhos/SP. 13279-390 ☎ +55 (19) 3849-5555 @ contato@ams-fa.com